

# An example abstract for the SCEE-2002 Conference

S.H.M.J. Houben\*

March 11, 2002

## 1 Introduction

The 4th International Conference on Scientific Computing in Electrical Engineering SCEE2002 will be organised from 23 to 28 June, 2002, in Eindhoven, The Netherlands. This conference, which has been organised twice before as a German conference and in 2000 as an international conference, will again aim at an international audience. To stress this fact, the conference will this year be organised in The Netherlands. We aim to reach both mathematicians and electrical engineers, both from industry and from the academic world.

To stress the importance of new computational methods for the industry, a special Industry Day will be organised, in which people from industry are asked to present to give their opinion on what research is needed in the near future.

This is an example abstract for the SCEE-2002 Conference. Of course, you are free to modify this basic outline at will. Please send an extended abstract of two pages, in PostScript or PDF format. Please present results in your abstract, possibly with relevant figures and/or tables.

## 2 Equations

The Maxwell equations are given below.

$$\operatorname{rot} \mathbf{E} = -\frac{\partial \mathbf{B}}{\partial t}, \quad (1a)$$

$$\operatorname{rot} \mathbf{H} = \mathbf{J} + \frac{\partial \mathbf{D}}{\partial t}, \quad (1b)$$

$$\operatorname{div} \mathbf{D} = \rho, \quad (1c)$$

$$\operatorname{div} \mathbf{B} = 0. \quad (1d)$$

Note that we can refer to individual equations, such as (1c) or (1d). It is also possible to include tables.

\*Eindhoven University of Technology, e-mail: stephanh@win.tue.nl

symbol	name	unit
$\mathbf{E}$	electric field	$\frac{\text{V}}{\text{m}}$ (Volt per meter)
$\mathbf{H}$	magnetic field	$\frac{\text{A}}{\text{m}}$ (Ampere per meter)
$\mathbf{D}$	electric flux	$\frac{\text{C}}{\text{m}^2}$ (Coulomb per square meter)
$\mathbf{B}$	magnetic flux	T (Tesla)
$\mathbf{J}$	electric current	$\frac{\text{A}}{\text{m}^2}$ (Ampere per square meter)
$\rho$	electric charge	$\frac{\text{C}}{\text{m}^3}$ (Coulomb per cubic meter)

## 3 Topics

The SCEE2002 conference will address the following topics:

- Computational electro-magnetics
- Computational electrodynamics
- Circuit simulation
- Coupled problems

## 4 More on figures

It is possible to include PostScript figures in an abstract.

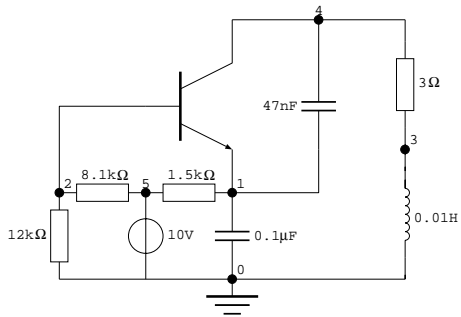

Another example:

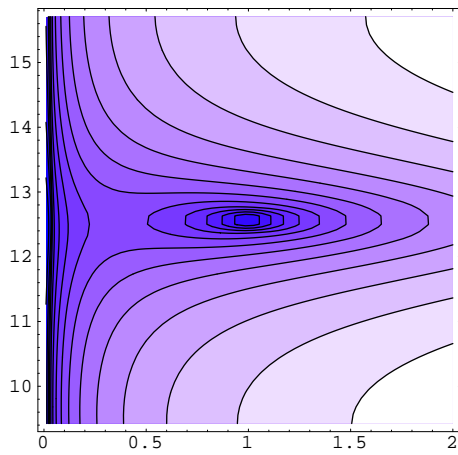

## 5 Conclusions

We hope it is clear how to create an abstract. With the example abstract provided, it is possible to create an abstract that includes text, equations and figures.