

Basic Research in Computer Science

BRICS NS-03-1 Cousot et al. (eds.): GETCO '03 Preliminary Proceedings

**Preliminary Proceedings of the Workshop on
Geometry and Topology in
Concurrency Theory**

GETCO '03

Marseille, France, September 6, 2003

**Patrick Cousot
Lisbeth Fajstrup
Eric Goubault
Maurice Herlihy
Kurtz Alexander
Martin Raußen
Vladimiro Sassone
(editors)**

BRICS Notes Series

ISSN 0909-3206

NS-03-1

August 2002

**Copyright © 2003, BRICS, Department of Computer Science
University of Aarhus. All rights reserved.**

**Reproduction of all or part of this work
is permitted for educational or research use
on condition that this copyright notice is
included in any copy.**

**See back inner page for a list of recent BRICS Notes Series publications.
Copies may be obtained by contacting:**

**BRICS
Department of Computer Science
University of Aarhus
Ny Munkegade, building 540
DK-8000 Aarhus C
Denmark
Telephone: +45 8942 3360
Telefax: +45 8942 3255
Internet: BRICS@brics.dk**

**BRICS publications are in general accessible through the World Wide
Web and anonymous FTP through these URLs:**

`http://www.brics.dk`
`ftp://ftp.brics.dk`
This document in subdirectory NS/03/1/

*GE*ometry and *TO*pology in *CO*ncurrency

Preliminary Proceedings of GETCO'2003
Satellite Workshop of CONCUR 2003
Marseille, France, 6. September, 2003

Patrick Cousot
Lisbeth Fajstrup
Eric Goubault
Maurice Herlihy
Alexander Kurtz
Martin Raussen
Vladimiro Sassone

Preliminary print under the patronage of
BRICS: Basic Research in Computer Science
Centre of the National Danish Research Foundation

Foreword

The main mathematical disciplines that have been used in theoretical computer science are discrete mathematics (especially, graph theory and ordered structures), logics (mostly proof theory for all kinds of logics, classical, intuitionistic, modal etc.) and category theory (cartesian closed categories, topoi etc.). General Topology has also been used for instance in denotational semantics, with relations to ordered structures in particular.

Recently, ideas and notions from mainstream “geometric” topology and algebraic topology have entered the scene in Concurrency Theory and Distributed Systems Theory (some of them based on older ideas). They have been applied in particular to problems dealing with coordination of multi-processor and distributed systems. Among those are techniques borrowed from algebraic and geometric topology: Simplicial techniques have led to new theoretical bounds for coordination problems. Higher dimensional automata have been modelled as cubical complexes with a partial order reflecting the time flows, and their homotopy properties allow to reason about a system’s global behaviour.

This workshop aims at bringing together researchers from both the mathematical (geometry, topology, algebraic topology etc.) and computer science side (concurrency theorists, semanticists, researchers in distributed systems etc.) with an active interest in these or related developments.

The workshop is held jointly with CMCIM 2003.

The first workshop on the subject “Geometric and Topological Methods in Concurrency Theory” was held in Aalborg, Denmark, in June 1999. GETCO 2000 was at Penn State University as a satellite to CONCUR 2000. GETCO 2001 was at Aalborg University as a satellite to CONCUR 2001. GETCO 2002 was at ENSEEIHT in Toulouse, France, as a satellite to DISC 2002.

The Workshop has been financially supported by CONCUR and by the Basic Research Institute in Computer Science (Aarhus, Denmark). I thank them for this, and more specially Uffe Engberg from BRICS who has been in charge of printing the preproceedings.

I also wish to thank the referees, the authors and the programme committee members for their very precise and timely job. Many thanks are also due to Michael Mislove who kindly supported the workshop by letting us submit the papers through the Electronic Notes in Theoretical Computer Science. Last but not least, I wish to thank the CONCUR organizers Peter Niebert, Roberto Amadio, Emmanuel Godard, Denis Lugiez, Remi Morin, Vincent Vanackere, Sarah Zennou and in particular the workshop coordinator, Silvano Dal Zilio, for making this possible.

Eric Goubault, August 2003.

Table of Contents

- pp. 1–15 *Topological (Bi-)Simulation*
by P. J. L. Cuijpers and M.A. Reniers.
- pp. 16–30 *Directed Homology*
by U. Fahrenberg.
- pp. 31–41 *The Homotopy Branching Space of a Flow*
by P. Gaucher
- pp. 42–46 *Simulations as Homotopies*
by K. Hess, P-E. Parent, A. Tonks and K. Worytkiewicz.
- pp. 47–50 *Oriented Combinatorial Topology and Concurrency*
by M. Johnson and Dominic Verity.

Topological (Bi-)Simulation

P.J.L. Cuijpers^{1,2} M.A. Reniers³

*Department of Mathematics and Computer Science
Technische Universiteit Eindhoven (TU/e)
Eindhoven, The Netherlands*

Abstract

In this paper, we reason that simulation and bisimulation are not adequate in the context of hybrid systems as they are only capable of comparing states that are reachable in a finite number of transitions. To solve this problem we extend labelled transition systems with a topology on the state space. We define topological versions of simulation and bisimulation that are also capable of comparing accumulation states of infinite sequences of transitions. We show that for transition systems with an indiscrete topology, topological (bi-)simulation and standard (bi-)simulation coincide. A similar result is obtained for finite transition systems with a discrete topology.

Key words: Labelled transition system, (bi-)simulation, topology, accumulation, topological (bi-)simulation.

1 Introduction

The semantics of many of the techniques used in computer science rely on labelled transition systems, structures containing a set of objects representing the physical state of a system (hence the objects are called states), and labelled transitions, representing the behavior that brings a system from one state into another.

Since the work of van Glabbeek [11] there is a general agreement within computer science that bisimulation [18,16] is the strongest notion of equivalence of interest on labelled transition systems. However, for example in the field of hybrid systems the need is felt for a stronger kind of equivalence than bisimulation. There, the problem of Zeno-behavior (an infinite number

¹ We would like to express our gratitude to Progress/STW (Grant EES5173), Philips-CFT and Assembleon, for their financial and material support of this project.

² Email: P.J.L.Cuijpers@tue.nl

³ Email: M.A.Reniers@tue.nl

*This is a preliminary version. The final version will be published in
Electronic Notes in Theoretical Computer Science
URL: www.elsevier.nl/locate/entcs*

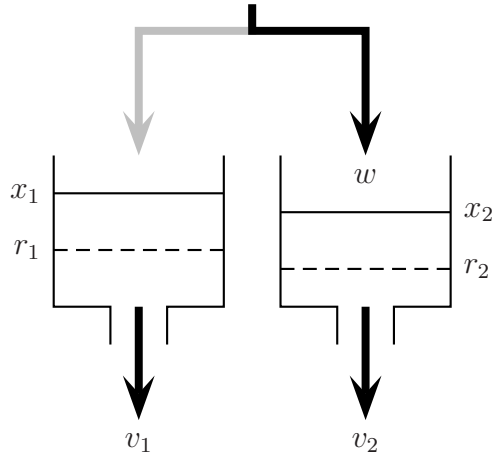

Fig. 1. Water tank system.

of events occurring in a finite time interval [20,6,3,13], also called supertask in philosophy [19,22]), gives rise to labelled transition systems that are considered different, but cannot be distinguished using bisimulation.

Although there is philosophical debate about the existence of Zeno-behavior in reality, there are some reasons why such a phenomenon arises in the modelling of hybrid systems. Next, we explain two such reasons by means of small examples taken, in both cases, from [13].

Zeno-behavior typically arises from modelling abstractions employed for the purpose of simplification of modelling hybrid systems. A simple example is the bouncing ball. A ball bounces on a surface elastically, with each bounce losing a fraction of its energy. In a simple model of such a bouncing ball, one might wish to abstract from the dynamics in case of a bounce of the ball on the surface and simply model it as a discrete event. As it turns out, in a finite amount of time, an infinite amount of bounces occur. Hence, the simple bouncing ball model employs Zeno-behavior.

Zeno-behavior also arises in models of hybrid systems as a result of applying certain control policies. This phenomenon is often referred to as infinitely fast switching between control modes. In [13] the example of the water tank system is given. The water tank system consists of two water tanks (see Figure 1). Water flows out each of these tanks with some constant rate (v_1 and v_2 respectively). At each moment, water flows into one (and precisely one) of the tanks with rate w . The objective is to keep the water volumes (x_1 and x_2 respectively) of the water tanks above some specified levels (r_1 and r_2 respectively). This is achieved by switching the inflow between the tanks at appropriate times: whenever $x_1 \leq r_1$ the inflow is switched to tank 1 and whenever $x_2 \leq r_2$ the inflow is switched to tank 2. If the inflow is bigger than each of the outflows ($w > v_1$ and $w > v_2$) and smaller than the sum of the outflows ($w < v_1 + v_2$), the system shows infinitely fast switching. This form of Zeno-behavior occurs frequently in models of hybrid systems due to the application of control policies such as chattering and relaxed control. Again, the Zeno-behavior is the consequence of a well-considered simplification of reality.

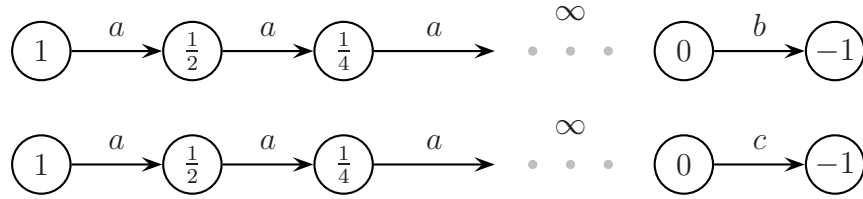

Fig. 2. Bisimilar labelled transition systems.

In many formalisms (such as hybrid automata [12]), the Zeno-behaviors that result from such modelling simplifications are neglected. It is not always clear what the implications are with respect to analysis and verification steps performed on such models especially in cases where properties are analyzed/verified that depend on the notion of reachability of states.

Bisimulation only regards a single transition at a time and is not capable of distinguishing between infinitely long sequences. For example, the sequences shown in Figure 2 are considered bisimilar. To be able to handle Zeno- and other kinds of infinite behavior, we need to define to which (set of) states an infinitely long sequence of states leads. This is possible in a natural way if a topological structure on the state space of the labelled transition system is given. Topology is a field of mathematics in which general definitions of accumulation of sequences have been developed (see e.g. [9,10]).

In this paper, we consider labelled transition systems where the state space is structured using a topology. Then, we define topological simulation and topological bisimulation. These notions extend the traditional ones by considering not only single steps but arbitrary long (accumulating) sequences of steps in the transfer (zig-zag) conditions. We prove that these notions are a pre-order and an equivalence respectively and that they are stronger than the non-topological notions. We also prove that they are invariant under isomorphism.

We study two specific topologies in more detail, viz. the indiscrete topology and the discrete topology. It turns out that for labelled transition systems with the indiscrete topology, (bi-)simulation and topological (bi-)simulation coincide under certain conditions. Also, for the discrete topology, the notions coincide provided that the state spaces are finite. The proofs that are omitted can be found in [5].

2 Preliminaries

In this section, we introduce some basic definitions and facts with respect to topology. Furthermore, we present the definition of the well-known notion of (bi-)simulation on labelled transition systems, but, for ease of comparison with the topological notions defined in the following section, already equipped with a topology (that is however not used yet).

2.1 Topology

Given a set X , a topology $T \subseteq 2^X$ is a way of adding structure to this set. Roughly speaking, a topology defines which points $U \subseteq X$ are in the neighborhood of a point $x \in U$. In literature from the field of computer science, structure on sets is usually added by giving a metric. In [6,14,13], this metric is defined on the state space, while [2,4] use a metric to define structure on the labels. This was, to our knowledge, never used with respect to bisimulation equivalence. Note that giving a metric on a set is only one way of inducing a topology. Alternatively, for example, a complete partial order gives rise to a topology as well [10,17]. The following definitions are taken from [9].

Definition 2.1 Let X be a set, then $T \subseteq 2^X$ is a *topology* on X if and only if $\emptyset \in T$, $X \in T$, every finite intersection of elements of T is again an element of T , and every arbitrary union of elements of T is again an element of T .

The elements of T are called *open sets*. An open set $U \in T$ containing $x \in U$ is called a *neighborhood* of x . The pair (X, T) is called a *topological space*. Two special topologies are the indiscrete topology $T_I(X) = \{\emptyset, X\}$ and the discrete topology $T_D(X) = 2^X$. They prove useful later on. As an example, the usual topology on the real numbers \mathbb{R} is the arbitrary union of all the sets $\{x \in \mathbb{R} \mid x_- < x < x_+ \text{ with } x_-, x_+ \in \mathbb{R}\}$ (i.e. the arbitrary union of *open intervals* (x_-, x_+)).

Definition 2.2 Let (X, T) be a topological structure. A set $B \subseteq T$ is a *basis* for T if and only if each non-empty element of T is the union of elements of B .

In Section 3, we use the concept of accumulation to expand the notion of bisimulation with.

Definition 2.3 Let (X, T) be a topological space, and $\vec{x} : \mathbb{N} \rightarrow X$ a sequence over X . This sequence \vec{x} *accumulates* at $y \in X$ according to the topology T , denoted $\vec{x} \xrightarrow{T} y$, if and only if for all neighborhoods U of y ($y \in U \in T$) and all $l \in \text{dom}(\vec{x})$ there exists $m \in \text{dom}(\vec{x})$ such that $l \leq m$ and $\vec{x}(m) \in U$.

Note that a sequence may accumulate in multiple accumulation points. Furthermore, a finite sequence accumulates at least at its endpoint.

Definition 2.4 Let (X, T) and (X', T') be topological spaces. A mapping $f : X \rightarrow X'$ is *continuous* if and only if $f^{-1}(U') \in T$ for each $U' \in T'$. The inverse image $f^{-1} : 2^{X'} \rightarrow 2^X$ of f is for all $V' \in 2^{X'}$ defined as $f^{-1}(V') = \{v \in X \mid f(v) \in V'\}$.

In this paper, for functions $f : Y \rightarrow Z$ and $g : X \rightarrow Y$, the function composition $f \circ g : X \rightarrow Z$ is defined as $(f \circ g)(x) = f(g(x))$ for all $x \in X$.

Lemma 2.5 *Let (X, T) and (X', T') be arbitrary topological spaces and let $f : X \rightarrow X'$ be an arbitrary continuous mapping. For any sequence \vec{x} over X , and any $x_\omega \in X$: if $\vec{x} \xrightarrow{T} x_\omega$, then $f \circ \vec{x} \xrightarrow{T'} f(x_\omega)$.*

Proof. Suppose that $\vec{x} \xrightarrow{T} x_\omega$. We have to prove that $f \circ \vec{x} \xrightarrow{T'} f(x_\omega)$. Let $U' \in T'$ be an arbitrary neighborhood of $f(x_\omega)$ and let $l \in \text{dom}(f \circ \vec{x})$. Since f is a continuous mapping between the topological spaces, we have the existence of a neighborhood $f^{-1}(U') \in T$ of x_ω . Furthermore, by definition, we have that $\text{dom}(\vec{x}) = \text{dom}(f \circ \vec{x})$. From $\vec{x} \xrightarrow{T} x_\omega$ we then have that there exists $m \in \text{dom}(\vec{x})$ such that $l \leq m$ and $\vec{x}(m) \in f^{-1}(U')$. Then, there also exists $m \in \text{dom}(f \circ \vec{x})$ such that $l \leq m$ and $(f \circ \vec{x})(m) \in f(f^{-1}(U'))$. \square

2.2 Labelled Transition Systems and (Bi-)Simulation

Definition 2.6 A *labelled transition system* is a tuple $\langle (X, T), \Sigma, \rightarrow \rangle$, where (X, T) is a *topological state space*, Σ is the set of *labels* describing behaviors, and $\rightarrow \subseteq X \times \Sigma \times X$ is the *transition relation*. As an abbreviation we write $x \xrightarrow{\sigma} y$ for $(x, \sigma, y) \in \rightarrow$.

In the remainder, we assume that M , M_1 , and M_2 are the labelled transition systems $\langle (X, T), \Sigma, \rightarrow \rangle$, $\langle (X_1, T_1), \Sigma, \rightarrow_1 \rangle$ and $\langle (X_2, T_2), \Sigma, \rightarrow_2 \rangle$, respectively.

Traditionally, states from labelled transition systems may be compared using simulation and bisimulation. A state x from some labelled transition system is said to be simulated by a state y from another labelled transition system, if the branching structure and the behavior of x can be mimicked by y . The inductive structure of the definition makes sure that all finite runs are considered, although only single steps are compared.

Definition 2.7 A binary relation $\mathcal{R} \subseteq X_1 \times X_2$ is a *simulation* if and only if for all $x_1 \in X_1$ and $x_2 \in X_2$ such that $x_1 \mathcal{R} x_2$

- if $x_1 \xrightarrow{\sigma}_1 x'_1$ for some $\sigma \in \Sigma$ and $x'_1 \in X_1$, then there exists $x'_2 \in X_2$ such that $x_2 \xrightarrow{\sigma}_2 x'_2$ and $x'_1 \mathcal{R} x'_2$.

A state $x_1 \in X_1$ of M_1 is *simulated* by a state $x_2 \in X_2$ of M_2 , denoted $M_1, x_1 \preceq M_2, x_2$, if and only if there exists a simulation $\mathcal{R} \subseteq X_1 \times X_2$ such that $x_1 \mathcal{R} x_2$.

Two states $x_1 \in X_1$ of M_1 and $x_2 \in X_2$ of M_2 are *bisimilar*, denoted $M_1, x_1 \leftrightarrow M_2, x_2$, if and only if there exists a binary relation $\mathcal{R} \subseteq X_1 \times X_2$ such that $x_1 \mathcal{R} x_2$ and both \mathcal{R} and \mathcal{R}^{-1} are simulations.

Simulation is a pre-order and bisimulation is an equivalence on the states of a system (see [11]). These notions can be lifted from states to systems as follows.

Definition 2.8 The labelled transition system M_1 is *simulated* by the labelled transition system M_2 if and only if for any state $x_1 \in X_1$ there is a state $x_2 \in X_2$ such that $M_1, x_1 \preceq M_2, x_2$. The labelled transition system M_1 is *bisimilar* to the labelled transition system M_2 if and only if for any state $x_1 \in X_1$ there is a state $x_2 \in X_2$ such that $M_1, x_1 \leftrightarrow M_2, x_2$, and vice versa, for any state $x_2 \in X_2$ there is a state $x_1 \in X_1$ such that $M_1, x_1 \leftrightarrow M_2, x_2$.

Often, when comparing different systems, also sets of initial states I_1 and I_2 are given. In such a case, we say that M_1 is simulated by M_2 if and only if every initial state in I_1 is simulated by an initial state in I_2 . In the remainder of this article, we do not consider initial states.

3 Topological Bisimulation

Recall that bisimulation is a way of comparing states of labelled transition systems by looking at the branching structure and the possible behavioral sequences. The formal definition of bisimulation regards two subsequent states and the label describing the behavior that accomplishes a transition from the first state into the second. Because this definition only compares single transitions at a time, finite sequences of labels and states are compared as well, but infinite sequences are not. The transitions in a labelled transition system give rise to sequences of states and labels, called runs.

Definition 3.1 A *run* of M is a pair $(\vec{x}, \vec{\sigma})$ of sequences $\vec{x} : \mathbb{N} \rightarrow X$ and $\vec{\sigma} : \mathbb{N} \rightarrow \Sigma$ such that

- either $\text{dom}(\vec{x}) = \text{dom}(\vec{\sigma}) = \mathbb{N}$ (for infinite runs), or $\text{dom}(\vec{x}) = [0, N + 1)$ and $\text{dom}(\vec{\sigma}) = [0, N)$ for some $N \in \mathbb{N}$ (for finite runs), and
- for all $n \in \text{dom}(\vec{\sigma})$: $\vec{x}(n) \xrightarrow{\vec{\sigma}(n)} \vec{x}(n + 1)$.

The length of a run $(\vec{x}, \vec{\sigma})$ is the cardinality of the domain of $\vec{\sigma}$.

Topology was introduced as a structuring mechanism on the state space in order to define the states where an infinite run accumulates. Next, we present topological versions of simulation and bisimulation that require that also the infinite behavior of the transition systems is taken into account by comparing the accumulation points of infinite runs.

Definition 3.2 A binary relation $\mathcal{R} \subseteq X_1 \times X_2$ is a *topological simulation* if and only if for all $x_1 \in X_1$ and $x_2 \in X_2$ such that $x_1 \mathcal{R} x_2$

- for all runs $(\vec{r}_1, \vec{\sigma})$ of M_1 and for all $y_1 \in X_1$ such that $\vec{r}_1(0) = x_1$: if $\vec{r}_1 \xrightarrow{T_1} y_1$, then there exists a run $(\vec{r}_2, \vec{\sigma})$ of M_2 and there exists $y_2 \in X_2$ such that $\vec{r}_2(0) = x_2$, $\vec{r}_2 \xrightarrow{T_2} y_2$, $y_1 \mathcal{R} y_2$, and $\vec{r}_1(n) \mathcal{R} \vec{r}_2(n)$ for all $n \in \text{dom}(\vec{r}_1)$.

A state $x_1 \in X_1$ of M_1 is *topologically simulated* by a state $x_2 \in X_2$ of M_2 , denoted $M_1, x_1 \preceq_{\text{top}} M_2, x_2$, if and only if there exists a topological simulation $\mathcal{R} \subseteq X_1 \times X_2$ such that $x_1 \mathcal{R} x_2$.

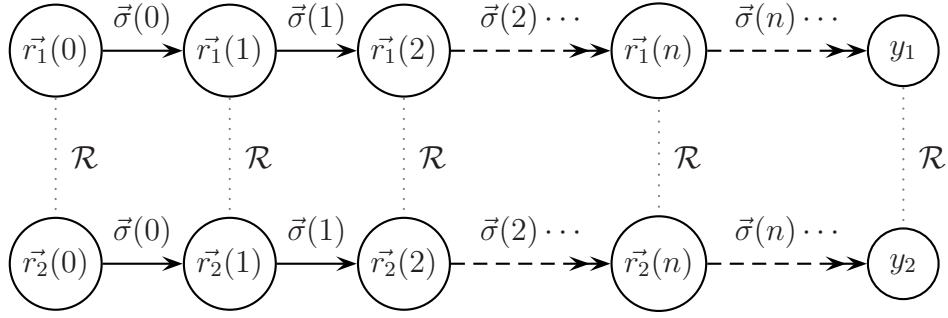

Fig. 3. Visualization of topological (bi-)simulation.

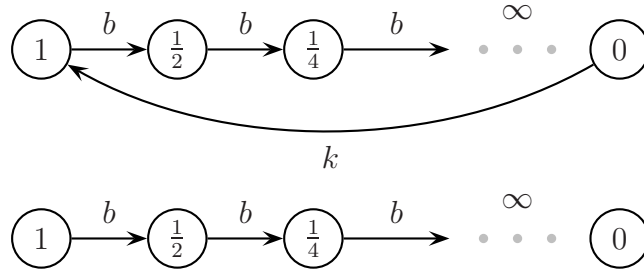

Fig. 4. Labelled transition systems for bouncing balls.

Two states $x_1 \in X_1$ of M_1 and $x_2 \in X_2$ of M_2 are *topologically bisimilar*, denoted $M_1, x_1 \xrightarrow{\text{top}} M_2, x_2$, if and only if there exists a binary relation $\mathcal{R} \subseteq X_1 \times X_2$ such that $x_1 \mathcal{R} x_2$ and both \mathcal{R} and \mathcal{R}^{-1} are topological simulations.

Observe that besides the accumulation point of the infinite runs also all intermediate states need to be related (see Figure 3). Since runs of length 1 are considered in the definition of topological (bi-)simulation, topological (bi-)simulation is a stronger notion than (bi-)simulation, which is proven in the next section.

To illustrate the usefulness of topological bisimulation we now consider again the example of the bouncing ball. The labelled transition systems in Figure 4, represent two versions of the bouncing ball. In these transition systems the state space consists of the non-negative reals (representing for example the energy of the ball) with the normal topology on those. The label b represents a bounce of the ball on the ground and the label k represents the ball being kicked up again. In the upper labelled transition system, once the ball comes to a rest, it is kicked up so that it starts bouncing again. In the lower labelled transition system, the ball is not kicked. The result is that no more actions occur. With respect to bisimulation, these transition systems are equivalent as the state where the difference occurs, is not reachable in a finite number of transitions. Our intuition about such a bouncing ball however is that we actually observe a difference between these two models. Using our notion of topological bisimulation, the difference between these labelled transition systems becomes manifest.

4 Properties

In this section, we give a number of properties of topological simulation and topological bisimulation. We start with proving that these notions are a pre-order and an equivalence respectively. Then, we discuss the relation between the non-topological and topological notions. We show that the topological notions are stronger than the non-topological ones. Finally, we show that the notions are indeed topological [9], i.e., invariant under isomorphism.

Theorem 4.1 *Topological simulation (\preceq_{top}) is a pre-order. Topological bisimulation ($\leftrightarrow_{\text{top}}$) is an equivalence.*

Next, we study the relations between the standard notions of simulation and bisimulation and their topological counterparts. As it turns out, the topological versions are stronger than the standard ones.

Theorem 4.2 $\preceq_{\text{top}} \subseteq \preceq$ and $\leftrightarrow_{\text{top}} \subseteq \leftrightarrow$.

On topological spaces the notion of isomorphism is defined in order to capture that the spaces have a corresponding structure. We show that topological simulation and topological bisimulation are topologically invariant.

Definition 4.3 A mapping $f : X_1 \rightarrow X_2$ is a *transition morphism* if and only if for all $x_1, x'_1 \in X_1$ and $\sigma \in \Sigma$: if $x_1 \xrightarrow{\sigma} x'_1$, then $f(x_1) \xrightarrow{\sigma} f(x'_1)$.

Definition 4.4 [Isomorphism] The labelled transition systems M_1 and M_2 are *isomorphic* if and only if there exists a bijective mapping $f : X_1 \rightarrow X_2$ such that both f and f^{-1} are continuous transition morphisms. Sometimes, we call such labelled transition systems *f-isomorphic*.

Lemma 4.5 *Let $f : X_1 \rightarrow X_2$ be a transition morphism. For any run $(\vec{r}, \vec{\sigma})$ of M_1 , $(f \circ \vec{r}, \vec{\sigma})$ is a run of M_2 .*

Theorem 4.6 *Let $f : X_1 \rightarrow X_2$ be a continuous transition morphism. Then, $M_1, x_1 \preceq_{\text{top}} M_2, f(x_1)$ for all $x_1 \in X_1$.*

Proof. Define $\mathcal{R} = \{(x_1, f(x_1)) \mid x_1 \in X_1\}$. We prove that \mathcal{R} is a topological simulation. Thereto, consider an arbitrary pair $(x_1, f(x_1)) \in \mathcal{R}$. Let $(\vec{r}, \vec{\sigma})$ be an arbitrary run of M_1 such that $\vec{r}(0) = x_1$. Let $y \in X_1$ such that $\vec{r} \xrightarrow{T_1} y$. From the fact that $(\vec{r}, \vec{\sigma})$ is a run of M_1 and the fact that f is a transition morphism, we obtain, by Lemma 4.5, that $(f \circ \vec{r}, \vec{\sigma})$ is a run of M_2 . Moreover $(f \circ \vec{r})(0) = f(\vec{r}(0)) = f(x_1)$. From the fact that $\vec{r} \xrightarrow{T_1} y$ and the fact that f is continuous, we obtain, by Lemma 2.5, that $f \circ \vec{r} \xrightarrow{T_2} f(y)$. Note that by definition $y \mathcal{R} f(y)$ and $\vec{r}(n) \mathcal{R} f(\vec{r}(n))$ for all $n \in \text{dom}(\vec{r})$. This proves that \mathcal{R} is a topological simulation. \square

Theorem 4.7 *For any two f-isomorphic M_1 and M_2 and any state $x_1 \in X_1$ we have $M_1, x_1 \leftrightarrow_{\text{top}} M_2, f(x_1)$.*

Proof. As $f : X_1 \rightarrow X_2$ is a continuous transition morphism, we have that $\mathcal{R} = \{(x_1, f(x_1)) \mid x_1 \in X_1\}$ is a topological simulation as is proven in the proof of the previous theorem. Similarly, as $f^{-1} : X_2 \rightarrow X_1$ is a continuous transition morphism, we have that $\mathcal{S} = \{(x_2, f^{-1}(x_2)) \mid x_2 \in X_2\}$ is a topological simulation. As $\mathcal{S} = \mathcal{R}^{-1}$, \mathcal{R} is a topological bisimulation. \square

5 Extreme Topologies

In the previous section, we have seen that the topological notions of simulation and bisimulation are stronger than their non-topological counterparts. An interesting question is whether there are topologies for which the notions coincide. We investigate this question for both the indiscrete and the discrete topology.

5.1 Indiscrete Topology

We show that for labelled transition systems with indiscrete topologies, called *indiscrete labelled transition systems*, the topological and non-topological notions of (bi-)simulation coincide provided that, non-topologically speaking, each state has a (bi-)similar state in the other labelled transition system. The reason for these provisions is that by moving from normal (bi-)simulation to topological bisimulation, some states become relevant (the accumulation points) that might not have been relevant in the non-topological setting. We require that for such states at least there is a related state in the other labelled transition system. This is captured by the notions of simulation and bisimulation on labelled transition systems as given in Definition 2.8.

Theorem 5.1 *For indiscrete M_1 and M_2 such that M_1 is simulated by M_2 , we have that for any $x_1 \in X_1$ and $x_2 \in X_2$: if $M_1, x_1 \preceq M_2, x_2$, then $M_1, x_1 \preceq_{\text{top}} M_2, x_2$.*

Proof. We prove that $\mathcal{R}' = \{(y_1, y_2) \in X_1 \times X_2 \mid M_1, y_1 \preceq M_2, y_2\}$ is a topological simulation with $x_1 \mathcal{R}' x_2$. Note that \mathcal{R}' is a simulation. Now, consider arbitrary $y_1 \in X_1$ and $y_2 \in X_2$ such that $y_1 \mathcal{R}' y_2$. Let $(\vec{r}_1, \vec{\sigma})$ be a run of M_1 and $z_1 \in X_1$ such that $\vec{r}_1(0) = y_1$. Suppose that $\vec{r}_1 \xrightarrow{T_1} z_1$. Now, we have to prove the existence of a run $(\vec{r}_2, \vec{\sigma})$ of M_2 and $z_2 \in X_2$ such that $\vec{r}_2(0) = y_2$, $\vec{r}_2 \xrightarrow{T_2} z_2$, $z_1 \mathcal{R}' z_2$, and $\vec{r}_1(n) \mathcal{R}' \vec{r}_2(n)$ for all $n \in \text{dom}(\vec{r}_1)$. From $y_1 \mathcal{R}' y_2$ and the fact that \mathcal{R}' is a simulation, we obtain the existence of a run $(\vec{r}_2, \vec{\sigma})$ such that $\vec{r}_2(0) = y_2$ and $\vec{r}_1(n) \mathcal{R}' \vec{r}_2(n)$ for all $n \in \text{dom}(\vec{r}_1)$. Furthermore, a special property of T_1 is that every sequence accumulates to every point in X_1 . Because M_1 is simulated by M_2 we have the existence of a $z_2 \in X_2$ such that $z_1 \mathcal{R}' z_2$. The indiscrete topology on X_2 then guarantees that $\vec{r}_2 \xrightarrow{T_2} z_2$. This concludes the proof. \square

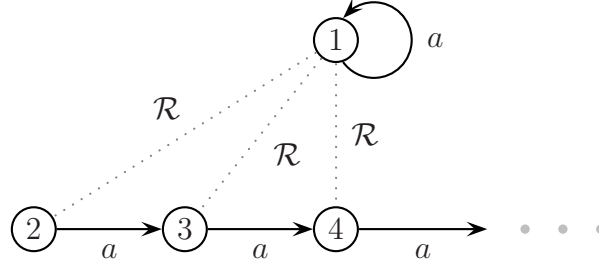

Fig. 5. A labelled transition system.

Theorem 5.2 *For indiscrete M_1 and M_2 such that M_1 is bisimilar to M_2 , and for any $x_1 \in X_1$ and $x_2 \in X_2$: if $M_1, x_1 \leftrightarrow M_2, x_2$, then $M_1, x_1 \leftrightarrow_{\text{top}} M_2, x_2$.*

As a direct consequence of the previous two theorems and Theorem 4.2, we have that for indiscrete labelled transition systems, the non-topological and topological notions coincide (of course with the same provisions).

5.2 Discrete Topology

In this section, we consider labelled transition systems where the state space is structured by a discrete topology, hence the name *discrete labelled transition systems*. For discrete labelled transition systems, we do not have that the non-topological and topological notions coincide! Consider the labelled transition system and the relation \mathcal{R} on the states of the labelled transition system given in Figure 5.

The relation $\mathcal{R} = \{(1, n), (n, 1) \mid n \in \mathbb{N} \wedge n > 1\}$, as depicted (suggestively) in the figure, is a witness for the following non-topological facts:

- state 1 is simulated by state 2, i.e., $1 \preceq 2$;
- state 2 is simulated by state 1, i.e., $2 \preceq 1$;
- the states 1 and 2 are bisimilar, i.e., $1 \leftrightarrow 2$.

Note that the bisimilarity of states 1 and 2 does not follow immediately from the simulations $1 \preceq 2$ and $2 \preceq 1$ because for bisimilarity the relation witnessing the simulations have to be each others inverse. The weaker equivalence $\preceq \cap \preceq^{-1}$ is called similarity in the literature [11] and it does not have this requirement.

Observe that we are now comparing states from the same labelled transition system. Hence, there can be no misunderstanding about the labelled transition system from which the states originate. Hence, we omit the labelled transition system from the notations.

Now, consider the topological notions under the assumption that the state space X of this labelled transition system is structured by means of the discrete topology $T_D(X) = 2^X$. State 2 is still simulated by state 1: $2 \preceq_{\text{top}} 1$. This is due to the following observations. State 2 has no infinite runs that accumulate. Hence, the infinite run does not have to be mimicked by such a run from state

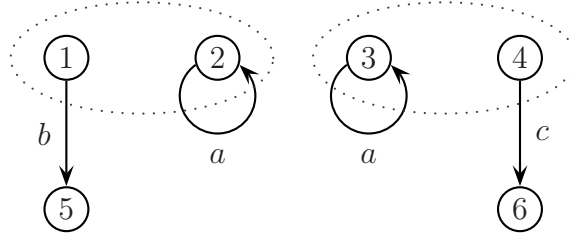

Fig. 6. Labelled transition system with a finite state space.

1. In this setting, however, state 1 is not simulated by state 2: $1 \not\prec_{\text{top}} 2$. State 1 has an infinite run that accumulates in state 1. Hence, state 2 should also have such a run and moreover it should accumulate in a state related to state 1. However, the run from state 2 does not accumulate at all. The same observations lead to the conclusion that state 1 and state 2 are not topologically bisimilar: $1 \not\leftrightarrow_{\text{top}} 2$.

Traditionally, in computer science, systems are assumed to be discrete and finite. Above we have shown that the assumption that the state spaces are structured by means of the discrete topology is not sufficient for concluding that the topological and non-topological notions coincide. Based on this, the reader might be tempted to believe that for labelled transition systems with a finite state space and an arbitrary topology, the non-topological and topological notions coincide. Again, this is not the case. Consider the labelled transition system depicted in Figure 6. The state space of this labelled transition system is finite: $X = \{1, 2, 3, 4, 5, 6\}$. Considering the non-topological notions, we observe that the states 2 and 3 simulate each other and are bisimilar.

Assume that the topology on this state space is given by the basis

$$B = \{\{1, 2\}, \{3, 4\}, \{5\}, \{6\}\}.$$

The open sets from this basis with more than one element are clustered in the figure. Now, due to the topological structure imposed on the state space, there is an infinite run $(\vec{x}, \vec{\sigma})$ with, for $n \in \mathbb{N}$, $\vec{x}(n) = 2$ and $\vec{\sigma}(n) = a$ that accumulates in state 1. In order for state 2 to be topologically simulated by state 3, this must mean that there is also an infinite run $(\vec{y}, \vec{\sigma})$ with $\vec{y}(0) = 3$ that accumulates in a state that is related to state 1. The only candidates for this accumulation are the states 3 and 4. But, neither of these can be related to state 1, as state 1 can execute the action b and states 3 and 4 cannot. A similar reasoning shows that state 3 cannot be simulated by state 2. Therefore, we have $2 \not\prec_{\text{top}} 3$ and $3 \not\prec_{\text{top}} 2$. As a consequence, the states are also not topologically bisimilar.

If the state space of a discrete labelled transition system is finite, however, the notions of (bi-)simulation and topological (bi-)simulation coincide.

Theorem 5.3 *For discrete M_1 and finite M_2 , we have that for all $x_1 \in X_1$ and $x_2 \in X_2$: $M_1, x_1 \preceq_{\text{top}} M_2, x_2$ if and only if $M_1, x_1 \preceq M_2, x_2$.*

Proof. The proof that the topological simulation implies the ordinary simulation follows from Theorem 4.2. It suffices to prove that ordinary simulation implies topological simulation. Suppose that $M_1, x_1 \preceq M_2, x_2$ is witnessed by the simulation \mathcal{R} . We prove that \mathcal{R} is also a topological simulation. Thereto, let $(\vec{r}, \vec{\sigma})$ be a run of M_1 with $\vec{r}(0) = x_1$ and let $y \in X$. Suppose that $\vec{r} \xrightarrow{T_1} y$. Let, for all $n \in \text{dom}(\vec{\sigma})$, $\vec{\sigma}_n : \mathbb{N} \rightarrow \Sigma$ be defined by $\vec{\sigma}_n(k) = \vec{\sigma}(k)$ for all $k < n$, and undefined otherwise. Hence, $\text{dom}(\vec{\sigma}_n) = [0, n)$.

First, we show, by induction on the natural number n , that there exists a run $(\vec{r}_n, \vec{\sigma}_n)$ of M_2 of length n with $\vec{r}_n(0) = x_2$ such that for all $k \leq n$ we have $\vec{r}(k) \mathcal{R} \vec{r}_n(k)$. For $n = 0$, we need to prove $\vec{r}(0) \mathcal{R} \vec{r}_0(0)$. Using $\vec{r}(0) = x_1$, $\vec{r}_0(0) = x_2$, and $x_1 \mathcal{R} x_2$, this follows immediately. Now, suppose there exists a run $(\vec{r}_n, \vec{\sigma}_n)$ such that $\vec{r}_n(0) = x_2$ and $\vec{r}(k) \mathcal{R} \vec{r}_n(k)$ for all $k \leq n$ (the induction hypothesis). As $\vec{r}(n) \mathcal{R} \vec{r}_n(n)$, $\vec{r}(n) \xrightarrow{\vec{\sigma}(n)} \vec{r}(n+1)$ and \mathcal{R} is a simulation relation we have the existence of $z \in X_2$ such that $\vec{r}_n(n) \xrightarrow{\vec{\sigma}(n)} z$ and $\vec{r}(n+1) \mathcal{R} z$. Define \vec{r}_{n+1} by $\vec{r}_{n+1}(i) = \vec{r}_n(i)$ for all $i \leq n$, $\vec{r}_{n+1}(n+1) = z$, and undefined otherwise. Then we have the existence of a run $(\vec{r}_{n+1}, \vec{\sigma}_{n+1})$ of M_2 such that $\vec{r}(k) \mathcal{R} \vec{r}_{n+1}(k)$ for all $k \leq n+1$.

All that remains to be proven is the existence of an accumulation point $z \in X_2$ such that $\vec{y} \xrightarrow{T_2} z$ and $y \mathcal{R} z$. Obviously, under the discrete topology, if \vec{y} is finite, the last element is the accumulation point. On the other hand, if \vec{y} is infinite, then, using the facts that $\vec{r} \xrightarrow{T_1} y$ and that T_1 is the discrete topology, we find that y itself occurs infinitely often in \vec{r} . Furthermore, each of those occurrences is bisimilar to the corresponding position in the sequence \vec{y} . As there are only finitely many different states, at least one of the states bisimilar to y occurs infinitely often. Hence, it is an accumulation point, say z , which obviously satisfies $y \mathcal{R} z$. \square

Theorem 5.4 *For discrete and finite M_1 and M_2 , we have that for all $x_1 \in X_1$ and $x_2 \in X_2$: $M_1, x_1 \xleftrightarrow{\text{top}} M_2, x_2$ if and only if $M_1, x_1 \xleftrightarrow{} M_2, x_2$.*

Proof. The theorem follows immediately from the previous theorem. \square

6 Conclusive remarks

We may conclude that the general agreement, that bisimulation is the strongest notion of equivalence of interest on labelled transition systems, common since the work of van Glabbeek [11], holds, as long as there is no topological structure on the state space. When phenomena like Zeno-behavior in hybrid systems are a reason to introduce and study accumulation points of sequences, a topological structure on the state space is a prerequisite. Choosing such a topology is a creative process, although it is often guided by knowledge of the application domain. In this paper, we have given definitions of topological simulation and bisimulation to answer this need. Amongst others, we have shown that a discrete topology results in the normal bisimulation for finite

state spaces, while other topologies make it possible to differentiate between infinite behaviors, like Zeno-behavior.

The notion of topological bisimulation considered in this paper is only capable of discriminating labelled transition systems based on first-order accumulation points. In [7], a reformulation of topological (bi-)simulation is presented that also deals with higher-order accumulation points. A crucial difference between that research and the research presented in this paper is that in [7] the concept of a run (over natural numbers) is replaced by the concept of a hybrid run (over ordinal numbers).

The type of labelled transition systems considered in this paper is rather limited. In the literature, labelled transition systems not only have a transition relation but also one or more predicates are defined on the state space to indicate, for example, initial and final states. Future research may be concerned with how to deal with predicates on labelled transition systems in general.

Büchi automata and other types of automata on infinite words [15] are usually equipped with one or more acceptance sets and a more sophisticated notion of acceptance of infinite words. We conjecture that, neglecting the fact that Büchi automata only consider infinite words, a topology can be used to encode the acceptance set in Büchi automata. The Büchi acceptance set then forms the basis of the topology. Topological bisimulation in itself captures the infinite aspects of Büchi automata. It is a stronger notion than language equivalence for infinite words. Further research is needed to substantiate those claims.

Related Work

In the literature from the field of computer science, structure on sets is usually added by giving a metric. In [6,14,13], this metric is defined on the state space, while [2,4] use a metric to define structure on the labels. Furthermore, this was, to our knowledge, never used with respect to bisimulation equivalence.

In [4], both the state space and the label space are endowed with metrics. The purpose is in proving operational models defined in terms of labelled transition systems equal to denotational semantics.

In [8], bisimulation is characterized using a specific (Alexandroff) topology as continuity of the transition relation. In other words, the author shows that the Alexandroff topology as a structure fits normal bisimulation. We, on the other hand, adapt the notion of bisimulation to take the topological structure of the state space into account.

In [1], the state space of a Kripke model for propositional modal logic is extended with a topology. This topology defines the accessibility relation between points in the model and hence defines the meaning of the modal operators. Consequently, bisimulation is also defined in terms of the open sets of this topology. These open sets play the role of our transition relations, rather than being an additional structure on the state space. The relation

between their notion of bisimulation and our notion of topological bisimulation is not clear yet.

In [21], also, a relation between transition systems and topology is studied. Amongst others, a definition is given for the limit of a sequence of transition systems. The strength of this work is that it allows for reasoning about *approximate equality* between systems. Still, this is a different approach to limits than the one we have chosen in this paper.

Acknowledgement

We acknowledge Jan Friso Groote, Ka Lok Man, MohammadReza Mousavi, Erik de Vink, Marc Voorhoeve, and Hans Zantema for interesting discussions and reading preliminary versions of this paper. Their comments have been very helpful.

References

- [1] M. Aiello, J. van Benthem, and G. Bezhanishvili. Reasoning about space: The modal way. Technical Report PP-2001-18, University of Amsterdam, 2001.
- [2] J.W. de Bakker and E.P. de Vink. *Control Flow Semantics*. Foundations of Computing Series. MIT Press, 1996.
- [3] B. Bérard and C. Picaronny. Accepting Zeno words: a way toward timed refinements. *Acta Informatica*, 37(1):45–81, 2000.
- [4] F. van Breugel. A theory of metric labelled transition systems. In S. Andima, B. Flagg, J. Itzkowitz, Y. Kong, R. Kopperman, and P. Misra, editors, *Papers on General Topology and Applications: 11th Summer Conference at the University of Southern Maine*, volume 806 of *Annals of the New York Academy of Sciences*, pages 67–87, Gorham, August 1995. The New York Academy of Sciences.
- [5] P.J.L. Cuijpers and M.A. Reniers. Topological (bi-)simulation. Technical Report CSR 02-04, Technische Universiteit Eindhoven (TU/e), Eindhoven, The Netherlands, 2002.
- [6] P.J.L. Cuijpers, M.A. Reniers, and A.G. Engels. Beyond Zeno-behaviour. Technical Report CSR 01-04, Technische Universiteit Eindhoven (TU/e), Eindhoven, The Netherlands, 2001.
- [7] P.J.L. Cuijpers, M.A. Reniers, and W.P.M.H. Heemels. Hybrid transition systems. Technical Report CSR 02-12, Technische Universiteit Eindhoven (TU/e), Eindhoven, Netherlands, 2002.
- [8] J.M. Davoren. Topologies, continuity and bisimulations. *Theoretical Informatics and Applications*, 33(4/5):357–381, 1999.
- [9] J. Dugundji. *Topology*. Allyn and Bacon, Inc., Boston, 1966.

- [10] R. Engelking. *General Topology*. Heldermann Verlag, 1989.
- [11] R.J. van Glabbeek. The linear time – branching time spectrum I. The semantics of concrete sequential processes. In J.A. Bergstra, A. Ponse, and S.A. Smolka, editors, *Handbook of Process Algebra*, chapter 1, pages 3–99. Elsevier Science Publishers B.V., Amsterdam, 2001.
- [12] T.A. Henzinger. The theory of hybrid automata. In *Proceedings of the 11th Annual IEEE Symposium on Logic in Computer Science (LICS 1996)*, pages 278–292. IEEE Computer Society Press, 1996.
- [13] K.H. Johansson, M. Egerstedt, J. Lygeros, and S. Sastry. On the regularization of Zeno hybrid automata. *System and Control Letters*, 38:141–150, 1999. Special issue on Hybrid Systems.
- [14] R. Kennaway, J.W. Klop, M.R. Sleep, and F.-J. de Vries. Transfinite reductions in orthogonal term rewriting systems. In R.V. Book, editor, *Proceedings of the Fourth International Conference on Rewriting Techniques and Applications*, volume 488 of *Lecture Notes in Computer Science*, pages 1–12, Como, Italy, April 1991. Springer-Verlag.
- [15] J. van Leeuwen, editor. *Handbook of Theoretical Computer Science*, volume B: Formal Models and Semantics. Elsevier Science Publishers B.V., Amsterdam, 1990.
- [16] R. Milner. *A Calculus of Communicating Systems*, volume 92 of *Lecture Notes in Computer Science*. Springer-Verlag, 1980.
- [17] M.W. Mislove. Algebraic posets, algebraic cpo’s and models of concurrency. In G.M. Reed, A.W. Roscoe, and R. Wachter, editors, *Topology and Category Theory in Computer Science*, pages 75–111. Clarendon Press, 1991.
- [18] D.M.R. Park. Concurrency and automata on infinite sequences. In P. Deussen, editor, *Proceedings 5th GI Conference*, volume 104 of *Lecture Notes in Computer Science*, pages 167–183. Springer-Verlag, 1981.
- [19] W. Salmon, editor. *Zeno’s Paradoxes*. Bobbs-Merril, Indianapolis, 1970.
- [20] A.J. van der Schaft and J.M. Schumacher. *An Introduction to Hybrid Dynamical Systems*, volume 251 of *Lecture Notes in Control and Information Sciences*. Springer-Verlag, London, 2000.
- [21] M. Ying. *Topology in Process Calculus: Approximate Correctness and Infinite Evolution of Concurrent Programs*. Springer-Verlag, 2001.
- [22] E.N. Zalta, editor. *Stanford Encyclopedia of Philosophy*. The Metaphysics Research Lab, CSLI, Stanford University, 2001. <http://plato.stanford.edu>.

Directed Homology

Ulrich Fahrenberg

*Dept. of Mathematical Sciences, Aalborg University
9220 Aalborg East, Denmark. Email: uli@math.auc.dk*

Abstract

We introduce a new notion of directed homology for cubical sets with connections and transpositions. We show that it respects directed homotopy and is functorial, and that it reduces to the usual homology in case of reversible cubical sets. However it has an undesired cancellation property, which we propose to remedy by refining the dihomology relation.

1 Introduction

It appears to be more and more recognized that using geometric reasoning, one can gain valuable insights in concurrency theory. However as there is an implicit notion of *time* in concurrency theory, the good geometric models to use are not usual topological spaces, but *directed* spaces, e.g. the lpo-spaces of Fajstrup, Goubault, and Raussen [3], the di-spaces of Grandis [4], and others.

In recent years we have seen several notions of *directed homotopy* emerge. It has been shown that these can be used in analyzing concurrent systems, and active research is being done in refining them and making them useful tools in concurrency theory.

In ordinary algebraic topology however, homotopy is only a useful tool in conjunction with *homology*; hence in directed topology, one should put efforts in developing a notion of *directed homology*. This article is a report on some progresses recently made with this issue.

In his recent papers [5,6], Marco Grandis has also introduced a notion of directed homology. What we define in this paper differs from his notion, and the relationship between the two is yet to be explored.

Exposition

We start out with a definition of cubical sets, which are the combinatorial counterparts of directed topological spaces. We work with “full-featured” cubical sets, including connections and transpositions. Following that, we introduce the notion of formal sums of cubes and their boundary operators.

*This is a preliminary version. The final version will be published in
Electronic Notes in Theoretical Computer Science
URL: www.elsevier.nl/locate/entcs*

Using the latter, we can define a notion of directed homology for cubical sets *in all odd dimensions*.

We show that our notion of dihomology respects directed homotopy, and that it is functorial. Also, in case the cubical set in question stems from a non-directed topological space, dihomology reduces to the usual homology notion.

We give a detailed example of some dihomology calculations, and we show that our dihomology notion has a certain cancellation property which makes it rather unsuited for applications. We proceed by refining it, arriving at a notion of *restricted dihomology*, which however currently only is defined in dimension 1. We show that restricted dihomology enjoys all the good properties of the original dihomology notion, without fulfilling the cancellation property from above.

2 Cubical Sets and Their Morphisms

We work in the *extended cubical site* \mathbb{K} of [7]; to settle notation, we give a definition here. Notice that the set \mathbb{N} of natural numbers includes 0; if we want to exclude 0 we write \mathbb{N}_+ .

A cubical set is a graded set $X = \{X_n\}_{n \in \mathbb{N}}$ together with mappings $\delta_i^\alpha : X_n \rightarrow X_{n-1}$ ($i = 1, \dots, n, \alpha = 0, 1$; *face maps*), $\varepsilon_i : X_n \rightarrow X_{n+1}$ ($i = 1, \dots, n+1$; *degeneracies*), $\gamma_i^\alpha : X_n \rightarrow X_{n+1}$ ($i = 1, \dots, n, \alpha = 0, 1$; *connections*), and $\sigma_i : X_n \rightarrow X_n$ ($i = 1, \dots, n-1, n \geq 1$; *transpositions*). These are subject to the following constraints:

$$\begin{aligned} \delta_i^\alpha \delta_j^\beta &= \delta_{j-1}^\beta \delta_i^\alpha & (i < j) \\ \varepsilon_i \varepsilon_j &= \varepsilon_{j+1} \varepsilon_i & (i \leq j) \\ \delta_i^\alpha \varepsilon_j &= \begin{cases} \varepsilon_{j-1} \delta_i^\alpha & (i < j) \\ \varepsilon_j \delta_{i-1}^\alpha & (i > j) \\ \text{id} & (i = j) \end{cases} \\ \gamma_i^\alpha \gamma_j^\beta &= \gamma_{j+1}^\beta \gamma_i^\alpha & (i < j) \\ \gamma_i^\alpha \gamma_i^\alpha &= \gamma_{i+1}^\alpha \gamma_i^\alpha \\ \gamma_i^\alpha \varepsilon_j &= \begin{cases} \varepsilon_{j+1} \gamma_i^\alpha & (i < j) \\ \varepsilon_j \gamma_{i-1}^\alpha & (i > j) \\ \varepsilon_i \varepsilon_i & (i = j) \end{cases} \\ \delta_i^\alpha \gamma_j^\beta &= \begin{cases} \gamma_{j-1}^\beta \delta_i^\alpha & (i < j) \\ \gamma_j^\beta \delta_{i-1}^\alpha & (i > j+1) \\ \text{id} & (i = j, j+1; \alpha = \beta) \\ \varepsilon_j \delta_j^\alpha & (i = j, j+1; \alpha \neq \beta) \end{cases} \end{aligned}$$

$$\begin{aligned}
 \sigma_i \sigma_i &= \text{id} \\
 (\sigma_i \sigma_{i+1})^3 &= \text{id} \\
 \sigma_i \sigma_j &= \sigma_j \sigma_i \quad (i \neq j-1, j, j+1) \\
 \delta_i^\alpha \sigma_j &= \begin{cases} \delta_i^\alpha & (i \neq j, j+1) \\ \delta_{i+1}^\alpha & (i = j) \\ \delta_{i-1}^\alpha & (i = j+1) \end{cases} \\
 \sigma_i \varepsilon_j &= \begin{cases} \varepsilon_{i+1} & (j = i) \\ \varepsilon_i & (j = i+1) \\ \varepsilon_j \sigma_i & (j \neq i, i+1) \end{cases} \\
 \sigma_i \gamma_i^\alpha &= \gamma_i^\alpha \\
 \sigma_i \gamma_j^\alpha &= \gamma_j^\alpha \sigma_i \quad (i \neq j-1, j, j+1)
 \end{aligned}$$

The mappings δ_i^α and ε_i are part of what seems to be the standard definition of “cubical complex,” cf. [2,3], the connection and transposition maps are what makes our “cubical site” *extended* in the sense of [7]. Note that the σ_i are required to fulfill the Coxeter axioms for generators of the symmetric group.

A *semicubical set* is a graded set X with only the δ_i^α mappings defined (which then are required to fulfill the first of the equalities from above).

The standard example of a cubical set is the singular cubical complex of a topological space: If X is a topological space, let $S_n X = \text{Top}(I^n, X)$, the set of all continuous maps $I^n \rightarrow X$, where I is the unit interval. If the maps δ_i^α , ε_i , γ_i^α , and σ_i are given by

$$\begin{aligned}
 \delta_i^\alpha f(t_1, \dots, t_{n-1}) &= f(t_1, \dots, t_{i-1}, \alpha, t_i, \dots, t_{n-1}) \\
 \varepsilon_i f(t_1, \dots, t_n) &= f(t_1, \dots, \hat{t}_i, \dots, t_n) \\
 \gamma_i^0 f(t_1, \dots, t_n) &= f(t_1, \dots, t_{i-1}, \max(t_i, t_{i+1}), t_{i+2}, \dots, t_n) \\
 \gamma_i^1 f(t_1, \dots, t_n) &= f(t_1, \dots, t_{i-1}, \min(t_i, t_{i+1}), t_{i+2}, \dots, t_n) \\
 \sigma_i f(t_1, \dots, t_n) &= f(t_1, \dots, t_{i-1}, t_{i+1}, t_i, t_{i+2}, \dots, t_n),
 \end{aligned}$$

then $SX = \{S_n X\}$ is a cubical set.

However the reversion of the topological unit interval, $\rho : t \mapsto 1 - t$, also induces other mappings $\rho_i : S_n X \rightarrow S_n X$, $i = 1, \dots, n$, called *reflections* in [7] and *reversions* in [2] and given by

$$\rho_i f(t_1, \dots, t_n) = f(t_1, \dots, t_{i-1}, 1 - t_i, t_{i+1}, \dots, t_n),$$

and we do not consider these. Cubical sets with reflections are well-suited models for topological spaces [2]; cubical sets *without* reflections are well-suited models for *directed* topological spaces, [3,4].

3 Directed Homology of Cubical Sets

In [2], the authors define partial composition operations on n -cubes, amounting to the “gluing” of two n -cubes along a common face. For our purposes, we are interested in a more general composition, allowing for arbitrary (formal) sums of n -cubes.

Given a cubical set $X = \{X_n\}$, let $\mathbb{N} \cdot X = \{\mathbb{N} \cdot X_n\}$, the graded set of free abelian monoids on the X_n , together with mappings $\delta_i^0, \delta_i^1 : \mathbb{N} \cdot X_n \rightrightarrows \mathbb{N} \cdot X_{n-1}$ ($i = 1, \dots, n$),

$$\sum_j x_j \mapsto \sum_j (\delta_i^1 x_j - \delta_i^0 x_j) \rightrightarrows (\delta_i^0(\sum_j x_j), \delta_i^1(\sum_j x_j)), \quad (1)$$

where the mapping \rightrightarrows is induced by the function $\mathbb{Z} \rightarrow \mathbb{N} \times \mathbb{N}$,

$$x \mapsto \begin{cases} (-x, 0) & \text{if } x \leq 0, \\ (0, x) & \text{if } x \geq 0. \end{cases}$$

We “normalize” the set $\mathbb{N} \cdot X$ by dividing out degenerate elements; let $CX = \{C_n X\}$ be the graded set given by $C_0 X = \mathbb{N} \cdot X_0$, $C_n X = \mathbb{N} \cdot X_n / (\mathbb{N} \cdot \bigcup_{i=1}^n \varepsilon_i X_{n-1})$, the quotient monoid. As $\delta_i^\alpha \varepsilon_j = 0$ in $\mathbb{N} \cdot X$, the mappings δ_i^α pass on to CX .

Lemma 3.1 *CX , with the mappings δ_i^α as defined above, is a semicubical set.*

Proof. Let δ_i denote the first mapping in the composition of (1), that is, $\delta_i(\sum_k x_k) = \sum_k (\delta_i^1 x_k - \delta_i^0 x_k)$, and extend the δ_i to be defined on $\mathbb{Z} \cdot X$, by $\delta_i(-x) = -\delta_i x$. Then it is easy to show, using only the semicubical axiom on the δ_i^α , that $\delta_i \delta_j = \delta_{j-1} \delta_i$ for all $i < j$:

Let $x = \sum_{k=1}^r x_k \in X_n$, then

$$\begin{aligned} \delta_{j-1} \delta_i x &= \delta_{j-1} \left(\sum_{k=1}^r (\delta_i^1 x_k - \delta_i^0 x_k) \right) \\ &= \sum_{k=1}^r (\delta_{j-1}^1 \delta_i^1 x_k - \delta_{j-1}^1 \delta_i^0 x_k - \delta_{j-1}^0 \delta_i^1 x_k + \delta_{j-1}^0 \delta_i^0 x_k) \end{aligned} \quad (2)$$

and, on the other hand,

$$\begin{aligned} \delta_i \delta_j x &= \delta_i \left(\sum_{k=1}^r (\delta_j^1 x_k - \delta_j^0 x_k) \right) \\ &= \sum_{k=1}^r (\delta_i^1 \delta_j^1 x_k - \delta_i^1 \delta_j^0 x_k - \delta_i^0 \delta_j^1 x_k + \delta_i^0 \delta_j^0 x_k) \end{aligned}$$

We show that $\delta_i^1 \delta_j^1 x = \delta_{j-1}^1 \delta_i^1 x$, the other three cases are similar. First, if we are to compute $\delta_{j-1}^1 \delta_i^1 x$, only the $\delta_i^1 x_k$ parts in equation (2) above are

relevant, but some of these can have been canceled by some $\delta_i^0 x_k$. That is, there is an index set $K \subseteq \{1, \dots, r\}$ such that

$$\delta_{j-1} \delta_i^1 x = \delta_{j-1} \left(\sum_{k \in K} \delta_i^1 x_k \right) = \sum_{k \in K} (\delta_{j-1}^1 \delta_i^1 x_k - \delta_{j-1}^0 \delta_i^1 x_k)$$

Going one step further, we see that there is an index set $K' \subseteq K$ such that

$$\delta_{j-1}^1 \delta_i^1 x = \sum_{k \in K'} \delta_{j-1}^1 \delta_i^1 x_k$$

As for $\delta_i^1 \delta_j^1 x$, there are index sets $L' \subseteq L \subseteq \{1, \dots, r\}$ such that

$$\delta_i \delta_j^1 x = \delta_i \left(\sum_{k \in L} \delta_j^1 x_k \right) \quad \text{and} \quad \delta_i^1 \delta_j^1 x = \sum_{k \in L'} \delta_i^1 \delta_j^1 x_k$$

We claim that $K' = L' = K \cap L$, which will finish the proof.

Let $k \in \{1, \dots, r\}$ be an index such that $\delta_i^1 x_k$ is canceled out, i.e. there exists $\ell \in \{1, \dots, r\}$ such that $\delta_i^1 x_k = \delta_i^0 x_\ell$. Then

$$\delta_i^1 \delta_j^1 x_k = \delta_{j-1}^1 \delta_i^1 x_k = \delta_i^0 \delta_j^1 x_\ell$$

and hence $\delta_j^1 x_k$ is also canceled out. Similar applies if we assume that $\delta_j^1 x_k$ is canceled out, hence $K' = L' = K \cap L$. \square

We call CX the *semicubical monoid* on X . The maps δ_i^α determine other maps, giving CX the structure of a *globular set*: For any $n \in \mathbb{N}_+$, define $\partial^-, \partial^+ : C_n X \rightrightarrows C_{n-1} X$ by

$$\partial^- = \sum_{k=1}^n \delta_k^{(k+1) \bmod 2} \quad \partial^+ = \sum_{k=1}^n \delta_k^{k \bmod 2}$$

For convenience we also define $\partial^-, \partial^+ : C_0 X \rightarrow *$, the one-point set. This gives the set CX a structure

$$\cdots \begin{array}{c} \xrightarrow{\partial^+} \\ \xrightarrow{\partial^-} \end{array} C_n X \begin{array}{c} \xrightarrow{\partial^+} \\ \xrightarrow{\partial^-} \end{array} \cdots C_2 X \begin{array}{c} \xrightarrow{\partial^+} \\ \xrightarrow{\partial^-} \end{array} C_1 X \begin{array}{c} \xrightarrow{\partial^+} \\ \xrightarrow{\partial^-} \end{array} C_0 X \begin{array}{c} \xrightarrow{\partial^+} \\ \xrightarrow{\partial^-} \end{array} *$$

which by the following is a globular set.

Corollary 3.2 $\partial^\alpha \partial^- = \partial^\alpha \partial^+$

Now for any $n \in \mathbb{N}$, define a relation $\simeq_n \subseteq C_n X \times C_n X$, by declaring $x \simeq_n y$ if and only if there exists $A \in C_{n+1} X$ such that $\partial^- A = x$, $\partial^+ A = y$.

Lemma 3.3 *The relations \simeq_n are reflexive and transitive, and symmetric if n is odd.*

Proof. Reflexivity by connection: If $A = \gamma_1^1 x$, then $\partial^- A = \partial^+ A = x$.

Symmetry by transposition: Let $x, y \in C_n$ such that $x \approx y$, hence $x = \partial^- A$, $y = \partial^+ A$ for some $A \in C_{n+1}$. Let $\sigma = \sigma_1 \sigma_3 \cdots \sigma_n$, then

$$\partial^- \sigma A = \sum_{k=1}^{n+1} \delta_k^{(k+1) \bmod 2} \sigma A = \sum_{k=1}^{n+1} \delta_k^{k \bmod 2} A = \partial^+ A$$

and vice versa, hence $y \approx x$.

Transitivity by addition: We carry out this proof only for $n = 1$; the proof for general n poses some notational difficulties but is otherwise similar.

Let $x, y, z \in C_1$ such that $x \approx y \approx z$, i.e. $x = \partial^- A$, $y = \partial^+ A = \partial^- B$, $z = \partial^+ B$ for some $A, B \in C_2$. We shall construct an element $G \in C_2$, which is a sum of connection cubes, such that $\partial^-(A + B + G) = x$, $\partial^+(A + B + G) = z$.

Write $x = x_1 + x_2$, $y = y_1 + y_2 = \tilde{y}_1 + \tilde{y}_2$, $z = z_1 + z_2$, such that $x_1 = \delta_1^0 A$, $x_2 = \delta_2^1 A$, $y_1 = \delta_1^1 A$, $y_2 = \delta_2^0 A$, $\tilde{y}_1 = \delta_1^0 B$, $\tilde{y}_2 = \delta_2^1 B$, $z_1 = \delta_1^1 B$, $z_2 = \delta_2^0 B$. Let $A = A^1 + \cdots + A^k$, $B = B^1 + \cdots + B^\ell$, where all $A^j, B^j \in X_2$, and split up x , y , and z further, writing $x_i = x_i^1 + \cdots + x_i^k$, such that $x_i^j = \delta_1^0 A^j$ or $= 0$, depending on whether $\delta_1^0 A^j$ has been canceled out in the sum. x_2 , y_i , \tilde{y}_i , and z_i are split up similarly. We can assume that $k = \ell$ in the above, adding some $A^j = 0$ or $B^j = 0$ if necessary.

Then (again using δ_i for the first mapping in the composition of (1))

$$\begin{aligned} \delta_1(A + B) &= \sum_{j=1}^k (\delta_1^1 A^j - \delta_1^0 A^j) + \sum_{j=1}^k (\delta_1^1 B^j - \delta_1^0 B^j) \\ &= \sum_{j=1}^k (y_1^j - x_1^j + z_1^j - \tilde{y}_1^j) \end{aligned} \quad (3)$$

and similarly

$$\delta_2(A + B) = \sum_{j=1}^k (x_2^j - y_2^j + \tilde{y}_2^j - z_2^j).$$

In these sums we can have introduced some extra cancellation, as it might be the case that $y_i^j - \tilde{y}_i^{j'} = 0$ for some j, j' , or $z_i^j - x_i^{j'} = 0$. We will construct some connection cubes which will cancel out the remaining y_i^j , $\tilde{y}_i^{j'}$ and reintroduce the canceled-out z_i^j ; hence if G denotes the sum of these connection cubes, we will have $\delta_1(A + B + G) = \sum_{j=1}^k (z_1^j - x_1^j)$, and similarly for $\delta_2(A + B + G)$.

We need to identify which cancellations have actually occurred in (3). Organize the y_i^j et.al. into *disjoint canceling pairs*, i.e. let

$$\begin{aligned} I &= \{(j, j') \mid 0 \neq y_1^j = \tilde{y}_1^{j'}, j_1 = j_2 \iff j'_1 = j'_2\}, \\ J &= \{(j, j') \mid 0 \neq x_1^j = z_1^{j'}, j_1 = j_2 \iff j'_1 = j'_2\}, \end{aligned}$$

and let

$$\begin{aligned}
 g_0 &= \sum \{\tilde{y}_1^{j'} \mid \nexists j : (j, j') \in I\} \\
 g_1 &= \sum \{y_1^j \mid \nexists j' : (j, j') \in I\} \\
 h &= \sum \{x_1^j \mid \exists j' : (j, j') \in J\}
 \end{aligned} \tag{4}$$

i.e. the g_i are sums of all the y_1^j resp. $\tilde{y}_1^{j'}$ which we still need to cancel out, and h is the sum of all the x_1^j resp. $z_i^{j'}$ which have been canceled. Let

$$A' = A + B + \gamma_1^1 g_0 + \gamma_1^0 g_1 + \gamma_1^0 h,$$

then our claim is that $\partial^- A' = x$ and $\partial^+ A' = z$.

For $\delta_1 A'$, we have

$$\delta_1 A' = \sum_{j=1}^k (y_1^j - \tilde{y}_1^j + z_1^j - x_1^j) + g_0 - g_1 - h,$$

where the last three terms take care of canceling all the y_1^j and \tilde{y}_1^j which have not been canceled before, and of re-subtracting all the x_1^j which have been canceled by some z_1^j . Hence we end up with

$$\delta_1 A' = -x_1 + (z_1 - h),$$

and there is no more cancellation possible, whence $\delta_1^0 A' = x_1$, $\delta_1^1 A' = z_1 - h$.

For $\delta_2 A'$,

$$\begin{aligned}
 \delta_2 A' &= \sum_{j=1}^k (x_2^j - y_2^j + \tilde{y}_2^j - z_2^j) + g_0 - g_1 - h \\
 &= \left(x - \sum_{j=1}^k x_1^j\right) - \left(y - \sum_{j=1}^k y_1^j\right) + \left(y - \sum_{j=1}^k \tilde{y}_1^j\right) \\
 &\quad - \left(z - \sum_{j=1}^k z_1^j\right) + g_0 - g_1 - h \\
 &= x - z + \sum_{j=1}^k (y_1^j - \tilde{y}_1^j + z_1^j - x_1^j) + g_0 - g_1 - h \\
 &= x - z - x_1 + z_1 - h = x_2 - (z_2 + h),
 \end{aligned}$$

again with no cancellation possible. Thus $\delta_2^0 A' = z_2 + h$, $\delta_2^1 A' = x_2$, implying $\partial^- A' = x$, $\partial^+ A' = z$. \square

We can now define the directed homology of X in all *odd* dimensions, by declaring that

$$H_n(X) = C_n X / \approx_n \quad \text{for } n \text{ odd.}$$

then (again using the notation from the proof of Lemma 3.3)

$$\delta_1 A' = \sum_{i \neq j} y_i - x_j \quad \delta_2 A' = \sum_{i \neq j} x_i - y_j$$

and hence $\partial^- A' = x$, $\partial^+ A' = y$. \square

4.2 Induced Maps; Functoriality

A morphism of cubical sets is exactly what one would expect: Given cubical sets $(X, \delta, \varepsilon, \gamma, \sigma)$, $(Y, \tilde{\delta}, \tilde{\varepsilon}, \tilde{\gamma}, \tilde{\sigma})$ and a mapping $f = (f_n) : X \rightarrow Y$, then f is a morphism if $f_n \delta = \tilde{\delta} f_{n+1}$, $f_n \varepsilon = \tilde{\varepsilon} f_{n-1}$, $f_n \gamma = \tilde{\gamma} f_{n-1}$, $f_n \sigma = \tilde{\sigma} f_n$. We will omit the tildes from here on.

Now let there be given such a morphism $f : X \rightarrow Y$; this induces a homomorphism $f_\square : C_n X \rightarrow C_n Y$ in the natural way:

$$f_\square \left(\sum_i n_i x_i \right) \stackrel{\text{def}}{=} \sum_i n_i f(x_i) \quad (5)$$

Lemma 4.2 $\delta_i^\alpha f_\square = f_\square \delta_i^\alpha$, and hence $\partial^\alpha f_\square = f_\square \partial^\alpha$.

That is, f_\square is a morphism of globular sets.

Proof. To show that $\delta_i^\alpha f_\square = f_\square \delta_i^\alpha$ is an easy calculation, in which the condition $f_n \delta = \delta f_{n+1}$ ensures that cancellation occurs simultaneously. \square

Corollary 4.3 Given $x, y \in C_n X$, n odd; if $x \simeq_n y$, then $f_\square(x) \simeq_n f_\square(y)$.

Hence the morphism $f : X \rightarrow Y$ induces maps $f_* = H_* f : H_* X \rightarrow H_* Y$ in dihomology, given by $f_* \llbracket x \rrbracket = \llbracket f_\square(x) \rrbracket$.

Proposition 4.4 H_* is functorial: If $X \xrightarrow{f} Y \xrightarrow{g} Z$, then $(g \circ f)_* = g_* \circ f_*$, and $\text{id}_* = \text{id}$.

Proof. Let $x \in C_n X$ and write $x = \sum_i n_i x_i$, then

$$\begin{aligned} (g \circ f)_* \llbracket x \rrbracket &= \llbracket (g \circ f)_\square x \rrbracket \\ &= \llbracket \sum_i n_i g(f(x_i)) \rrbracket \\ &= \llbracket g_\square \left(\sum_i n_i f(x_i) \right) \rrbracket \\ &= \llbracket g_\square f_\square(x) \rrbracket = g_* \llbracket f_\square(x) \rrbracket = g_*(f_* \llbracket x \rrbracket). \end{aligned}$$

Also, $\text{id}_* \llbracket x \rrbracket = \llbracket \text{id}_\square x \rrbracket = \llbracket x \rrbracket$. \square

This also shows that the mapping $X \mapsto CX$, $f \mapsto f_\square$ is functorial.

4.3 Dihomology and (Ordinary) Homology

Let X be a cubical set with reflections $\rho_i : X_n \rightarrow X_n$, and notice that the reflections induce a notion of “inverse” of a cube: If $x \in X_n$, define $-x = \rho_1 \cdots \rho_n x$. Hence the free monoids $\mathbb{N} \cdot X_n$ are actually groups; they are isomorphic to the free abelian groups $\mathbb{Z} \cdot X_n$. The $C_n X$ in turn are then isomorphic to the groups in the normalized chain complex of X ; indeed, if we define mappings $d : C_n X \rightarrow C_{n-1} X$ by $d = \partial^+ - \partial^-$, CX with these mappings is isomorphic to the normalized chain complex.

It is also easy to see that the two equivalence relations \simeq_n (dihomology) and \sim_n (homology) are the same, however it is not true in general that our dihomology monoids (which in this case are groups, the inverses being $-[[x]] = [[-x]]$) are isomorphic to the usual homology groups, as these are defined by taking the quotient under \sim of the *group of loops* $\partial^{-1}(0) \subseteq C_n X$, whereas our $H_n(X)$ are the quotients under $\simeq = \sim$ of the full chain group $C_n X$.

Our dihomology groups hence take chains which are not loops into account, and their relation to the homology groups seems to be similar to the one of the fundamental groupoid [1] to the fundamental group.

5 Cancellation; Dihomology Fails a Test Case

Figure 1 shows a simple example of a cubical set, consisting of five 2-cubes glued together to form a hollow 3-cube without bottom face.

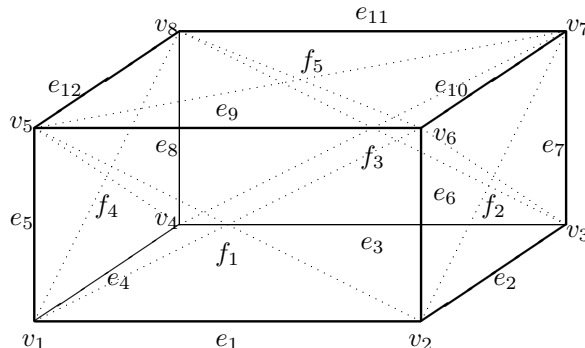

Fig. 1. The hollow 3-cube without bottom face.

For clarification we list the face maps from X_2 to X_1 , the others should be obvious from the figure:

$$\begin{array}{cccc}
 \delta_1^0 f_1 = e_1 & \delta_1^1 f_1 = e_9 & \delta_2^0 f_1 = e_5 & \delta_2^1 f_1 = e_6 \\
 \delta_1^0 f_2 = e_2 & \delta_1^1 f_2 = e_{10} & \delta_2^0 f_2 = e_6 & \delta_2^1 f_2 = e_7 \\
 \delta_1^0 f_3 = e_3 & \delta_1^1 f_3 = e_{11} & \delta_2^0 f_3 = e_8 & \delta_2^1 f_3 = e_7 \\
 \delta_1^0 f_4 = e_4 & \delta_1^1 f_4 = e_{12} & \delta_2^0 f_4 = e_5 & \delta_2^1 f_4 = e_8 \\
 \delta_1^0 f_5 = e_9 & \delta_1^1 f_5 = e_{11} & \delta_2^0 f_5 = e_{12} & \delta_2^1 f_5 = e_{10}
 \end{array}$$

In this example, the dipath $e_1 + e_2 + e_7$ can be “wrapped around” the cube’s faces, showing that there is a combinatorial dihomotopy between $e_1 + e_2 + e_7$ and $e_3 + e_4 + e_7$:

$$\begin{aligned}
 e_1 + e_2 + e_7 &\sim e_1 + e_6 + e_{10} && \text{by } \partial^- f_2 = e_2 + e_7, \quad \partial^+ f_2 = e_6 + e_{10} \\
 &\sim e_5 + e_9 + e_{10} && \text{by } \partial^- f_1 = e_1 + e_6, \quad \partial^+ f_1 = e_5 + e_9 \\
 &\sim e_5 + e_{12} + e_{11} && \text{by } \partial^- f_5 = e_9 + e_{10}, \quad \partial^+ f_5 = e_{12} + e_{11} \quad (6) \\
 &\sim e_4 + e_8 + e_{11} && \text{by } \partial^- f_4 = e_4 + e_8, \quad \partial^+ f_4 = e_5 + e_{12} \\
 &\sim e_4 + e_3 + e_7 && \text{by } \partial^- f_3 = e_3 + e_7, \quad \partial^+ f_3 = e_8 + e_{11}
 \end{aligned}$$

However for this “wrapping around” to work, the edge e_7 is essential, so the dipaths $e_1 + e_2$ and $e_3 + e_4$ are *not* dihomotopic.

By proposition 4.1, there exists a dihomology from $e_1 + e_2 + e_7$ to $e_3 + e_4 + e_7$, and we will make one such explicit below. We would also like dihomology to “keep apart” $e_1 + e_2$ from $e_3 + e_4$, however the next proposition shows that our notion of dihomology has a cancellation property (for $n = 1$) which implies that $e_1 + e_2 \overset{\sim}{\sim}_1 e_4 + e_3$:

Proposition 5.1 *Given $x, y, z \in C_1X$; if $x + z \overset{\sim}{\sim}_1 y + z$, then $x \overset{\sim}{\sim}_1 y$.*

Proof. By an inductive argument we can assume that $z \in X_1$, i.e. z is a single 1-cube. Let $A = \sum_j A_j \in C_2X$ such that $\partial^- A = x + z$, $\partial^+ A = y + z$, and write $x = x_1 + x_2$, $y = y_1 + y_2$, $z = z_1 + z_2 = z'_1 + z'_2$, such that $\delta_1^0 A = x_1 + z_1$, $\delta_2^1 A = x_2 + z_2$, $\delta_1^1 A = y_1 + z'_1$, $\delta_2^0 A = y_2 + z'_2$. As $z \in X_1$, either $z_1 = z$ and $z_2 = 0$, or $z_1 = 0$ and $z_2 = z$, similarly for the z'_i .

Now assume that $z_1 = z'_1$, then also $z_2 = z'_2$. Hence $\delta_1 A = \sum_j (\delta_1^1 A_j - \delta_1^0 A_j) = y_1 + z'_1 - x_1 - z_1 = y_1 - x_1$, similarly $\delta_2 A = x_2 - y_2$ and thus $\partial^- A = x$, a contradiction. Consequently, $z_1 \neq z'_1$ and $z_2 \neq z'_2$, which leaves us with the two cases that either $z_1 = z'_2 = z$, $z'_1 = z_2 = 0$, or $z_1 = z'_2 = 0$, $z'_1 = z_2 = z$.

In the first case, let $A' = A + \gamma_1^1 z$, then $\delta_1 A' = y_1 - x_1 - z + z = y_1 - x_1$ and $\delta_2 A' = x_2 - y_2 - z + z = x_2 - y_2$, hence $\partial^- A' = x$, $\partial^+ A' = y$. In the second case, let $A' = A + \gamma_1^0 z$ and repeat the calculations above. \square

Continuing our example, figure 2 shows an element $A \in C_2X$ such that $\partial^- A = e_1 + e_2 + e_7$, $\partial^+ A = e_3 + e_4 + e_7$.

Figure 3 shows how the cancellation property works.

6 Restricted Dihomology

To remedy the cancellation property from above, we define here another dihomology relation, which is a subset of the relation $\overset{\sim}{\sim}_1$ introduced in section 3 and keeps apart $e_1 + e_2$ and $e_3 + e_4$. We restrict ourselves to dimension 1.

For $x \in X_2$, define $\zeta^- x$, $\zeta^+ x$ (“lower and upper corner”) by $\zeta^- x = \delta_1^0 \delta_1^0 x$, $\zeta^+ x = \delta_1^1 \delta_1^1 x$. For formal sums of cubes, the corners are defined similarly to

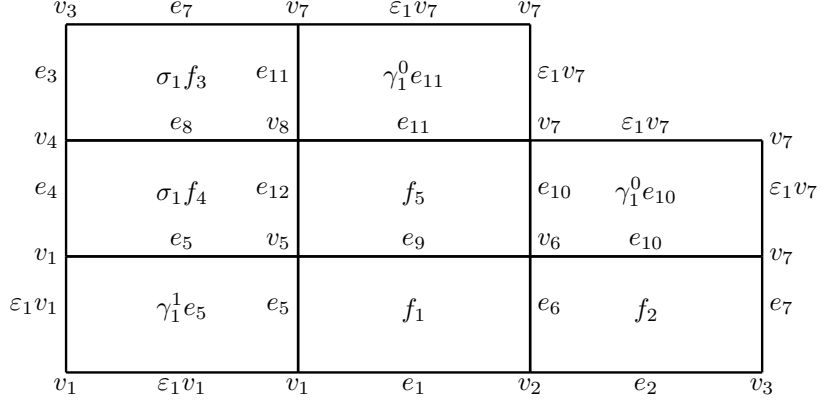

Fig. 2. $A = \sigma_1 f_3 + \gamma_1^0 e_{11} + \sigma_1 f_4 + f_5 + \gamma_1^0 e_{10} + \gamma_1^1 e_5 + f_1 + f_2$: $\partial^- A = e_1 + e_2 + e_7$, $\partial^+ A = e_3 + e_4 + e_7$.

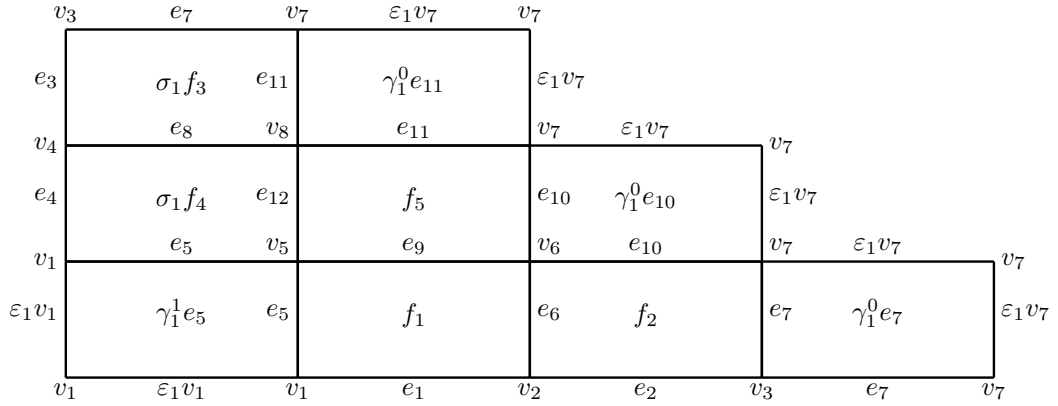

Fig. 3. $A' = A + \gamma_1^0 e_7$: $\partial^- A' = e_1 + e_2$, $\partial^+ A' = e_3 + e_4$.

what we did in (1):

$$\sum_j x_j \mapsto \sum_j (\zeta^+ x_j - \zeta^- x_j) \rightsquigarrow (\zeta^-(\sum_j x_j), \zeta^+(\sum_j x_j)), \quad (7)$$

Now given $x, y \in C_2 X$, say that $x \cdot \rightsquigarrow y$ if there is an $A \in C_2 X$ such that $\partial^- A = x$, $\partial^+ A = y$, and there exists $k \in \mathbb{N}$ such that $\zeta^- A = k \partial^- x$, $\zeta^+ A = k \partial^+ x$.

A trivial but critical property of the ζ^α is that they act on connection cubes in a sensible way:

$$\zeta^\alpha \gamma_1^\beta = \partial^\alpha$$

With this in mind, it is not difficult to see that most of the properties of the original dihomology relation carry over to the restricted one:

We can indeed form the quotient $C_1 X / \cdot \rightsquigarrow \cdot$:

Proposition 6.1 *The relation $\cdot \rightsquigarrow \cdot$ is an equivalence on $C_1 X$.*

Sketch of proof. We can copy the proof of lemma 3.3, adjusting it in a few

places. For reflexivity, if $A = \gamma_1^1 x$, then $\partial^- A = \partial^+ A = x$ and $\zeta^\alpha A = \partial^\alpha x$. For symmetry we note that $\zeta^\alpha \sigma_1 A = \zeta^\alpha A$. For transitivity, the basic idea is that if $\zeta^\alpha A = k \partial^\alpha x$ and $\zeta^\alpha B = \ell \partial^\alpha x$, then $\zeta^\alpha(A + B + G) = (k + \ell \pm i) \partial^\alpha x$, where i depends on what cancellations are involved. \square

The monoidal structure of $C_1 X$ carries over to the quotient:

Proposition 6.2 *If $x_1 \cdot \overset{\sim}{\sim} y_1$ and $x_2 \cdot \overset{\sim}{\sim} y_2$, then $x_1 + x_2 \cdot \overset{\sim}{\sim} y_1 + y_2$.*

Sketch of proof. This is like the proof of lemma 3.4, but again there are some cancellation issues which need to be resolved. \square

Restricted dihomology respects dihomotopy of dipaths:

Proposition 6.3 *If two dipaths x, y are combinatorially dihomotopic, then $x \cdot \overset{\sim}{\sim} y$.*

Proof. Again it suffices to show the proposition for elementary dihomotopy. And indeed, if A' is defined as in the proof of proposition 4.1, then $\zeta^\alpha A' = \partial^\alpha x$. \square

As for functoriality of restricted dihomology, section 4.2 can be taken over unchanged:

Proposition 6.4 *With induced maps defined as in (5), restricted dihomology is functorial.*

Finally, continuing the example from section 5, the cancellation property of proposition 5.1 does not hold for the restricted version of dihomology:

First we note that the sum of 2-cubes $A \in C_2$ of figure 2 does not fulfill $\zeta^- A = kv_1$, $\zeta^+ A = kv_7$ and hence cannot be used to show that $e_1 + e_2 + e_7 \cdot \overset{\sim}{\sim} e_3 + e_4 + e_7$. Adding two connection cubes remedies this situation, see figure 4. Note also figure 5; how the sum A'' can be split up into five parts, each consisting of a “real” cube and a connection cube, and each starting in v_1 and ending in v_7 . These five components correspond to the five steps in the “wrapping around” of (6).

To see that restricted dihomology does not identify $e_1 + e_2$ with $e_3 + e_4$, assume that there exists $B \in C_2 X$, $k \in \mathbb{N}$, such that $\partial^- B = e_1 + e_2$, $\partial^+ B = e_3 + e_4$, $\zeta^- B = kv_1$, $\zeta^+ B = kv_3$. If the sum B involves one of f_2, f_3 , or f_5 , or one of their transpositions, $\zeta^+ B$ contains a component v_7 , as there is no element of X_2 whose lower corner is v_7 . Similarly, if B has a component f_1 resp. f_4 , $\zeta^+ B$ involves v_6 resp. v_8 . Hence $B = 0$, a contradiction.

7 Future Work

We believe that the notion of *restricted dihomology* is the “good” directed homology notion to go after. It should not be too difficult to extend it to all odd dimensions, however we still miss the even dimensions.

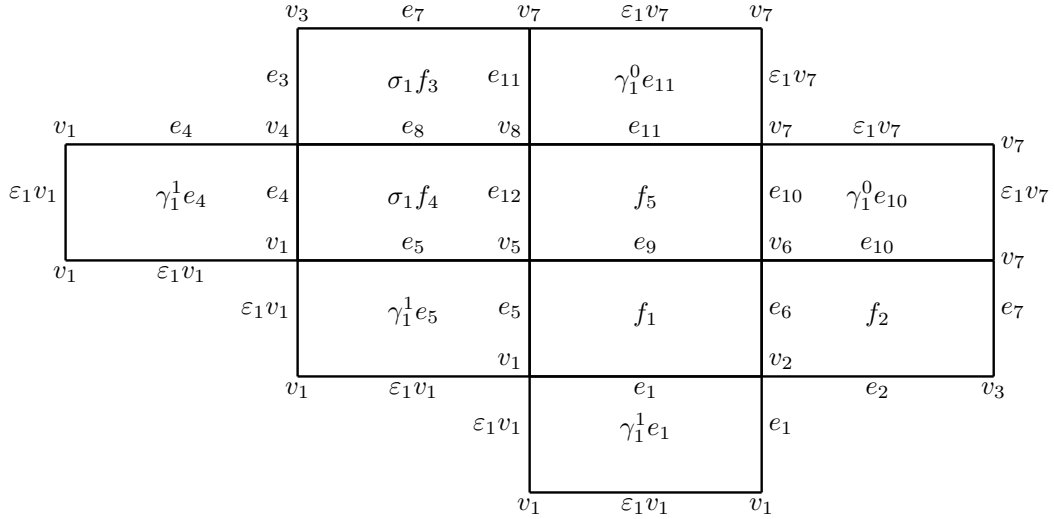

Fig. 4. $A'' = A + \gamma_1^1 e_4 + \gamma_1^1 e_1$: $\partial^- A'' = e_1 + e_2 + e_7$, $\partial^+ A'' = e_3 + e_4 + e_7$, $\zeta^- A'' = 5v_1$, $\zeta^+ A'' = 5v_7$.

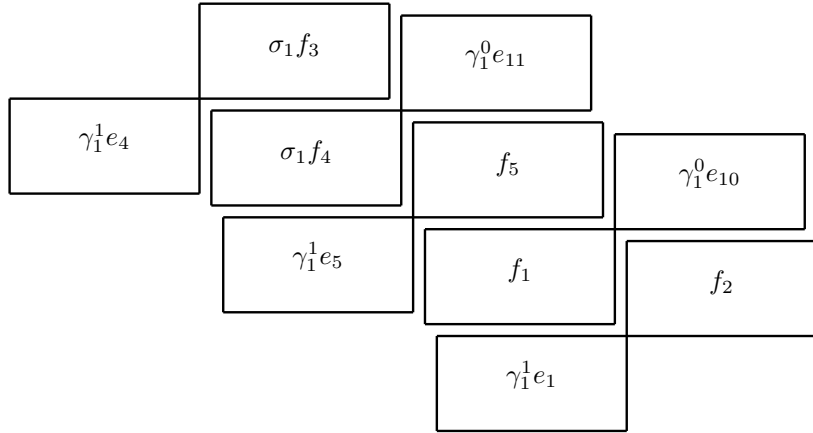

Fig. 5. A'' split up into five components.

Once we have a notion of restricted dihomology in all dimensions, we should also think about relative dihomology. To be able to actually do calculations, we need a notion of dihomology of a pair and some exact sequences.

On another issue, we need to explore the relation of our (restricted) dihomology relation to the one of Marco Grandis [5].

Acknowledgement

I am grateful to my supervisors and co-workers [Lisbeth Fajstrup](#) and [Martin Raussen](#) for sharing many valuable thoughts and ideas, and to [Marco Grandis](#), Emmanuel Haucourt, and [Stefan Sokołowski](#) for giving much-appreciated feedback during a [workshop](#) held at Aalborg University in December 2002.

References

- [1] Brown, R., *Groupoids and van Kampens theorem*, Proc. London Math. Soc. **17** (1967), pp. 385–401.
- [2] Brown, R. and P. J. Higgins, *On the algebra of cubes*, J. Pure Appl. Algebra **21** (1981), pp. 233–260.
- [3] Fajstrup, L., E. Goubault and M. Raussen, *Algebraic topology and concurrency*, Report R-99-2008, Department of Mathematical Sciences, Aalborg University (1999), <http://www.math.auc.dk/research/reports/R-99-2008.ps>.
- [4] Grandis, M., *Directed homotopy theory I*, Preprint 443, Univ. Genova (2001), <http://arXiv.org/abs/math.AT/0111048>.
- [5] Grandis, M., *Directed combinatorial homology and noncommutative tori*, Preprint 480, Univ. Genova (2003), <http://www.dima.unige.it/~grandis/Bsy.pdf>.
- [6] Grandis, M., *Normed combinatorial homology and noncommutative tori*, Preprint 484, Univ. Genova (2003), <http://www.dima.unige.it/~grandis/Bsy2.ps>.
- [7] Grandis, M. and L. Mauri, *Cubical sets and their site*, Theory and Applications of Categories **11** (2003), pp. 185–211, <http://www.tac.mta.ca/tac/volumes/11/8/11-08.ps>.

THE HOMOTOPY BRANCHING SPACE OF A FLOW

PHILIPPE GAUCHER

ABSTRACT. In this talk, I will explain the importance of the homotopy branching space functor (and of the homotopy merging space functor) in dihomotopy theory.

CONTENTS

1. Introduction	1
2. Model category	1
3. Reminder about the category of flows	3
4. The homotopy branching space functor	4
5. The homotopy merging space functor	5
6. First application: studying weak dihomotopy	6
7. Second application: a long exact sequence for the branching homology	9
References	11

1. INTRODUCTION

In [10], the reader will be able to find a survey of the different geometric approaches of concurrency. The model category of flows was introduced in [3] to model higher dimensional automata (HDA). It allows the study of HDA up to homotopy (cf. also [7, 8]). A good notion of homotopy of flows must preserve the computer scientific properties of the HDA to be modeled like the initial and final states, the deadlocks and the unreachable states. In particular, it must preserve the direction of time, hence the terminology *dihomotopy* for a contraction of *directed homotopy*. This way, instead of working in the category of flows itself, one can work in the localization of the category of flows with respect to *dihomotopy equivalences*.

I will explain in this talk the powerfulness of the homotopy branching space functor in dihomotopy theory. The corresponding papers are “Homotopy branching space and weak dihomotopy” [5] and “A long exact sequence for the branching homology” [4].

2. MODEL CATEGORY

If \mathcal{C} is a category, one denotes by $Map(\mathcal{C})$ the category whose objects are the morphisms of \mathcal{C} and whose morphisms are the commutative squares of \mathcal{C} .

In a category \mathcal{C} , an object x is a *retract* of an object y if there exists $f : x \rightarrow y$ and $g : y \rightarrow x$ of \mathcal{C} such that $g \circ f = \text{Id}_x$. A *functorial factorization* (α, β) of \mathcal{C} is a pair of functors from $Map(\mathcal{C})$ to $Map(\mathcal{C})$ such that for any f object of $Map(\mathcal{C})$, $f = \beta(f) \circ \alpha(f)$.

1991 *Mathematics Subject Classification*. 55P99, 68Q85.

Key words and phrases. concurrency, homotopy, homotopy colimit, model category, simplicial model category, exact sequence, cone, homology, localization.

Definition 2.1. [12, 11] Let $i : A \longrightarrow B$ and $p : X \longrightarrow Y$ be maps in a category \mathcal{C} . Then i has the left lifting property (LLP) with respect to p (or p has the right lifting property (RLP) with respect to i) if for any commutative square

$$\begin{array}{ccc} A & \xrightarrow{\alpha} & X \\ i \downarrow & \nearrow g & \downarrow p \\ B & \xrightarrow{\beta} & Y \end{array}$$

there exists g making both triangles commutative.

There are several versions of the notion of *model category*. The following definitions give the one we are going to use.

Definition 2.2. [12, 11] A model structure on a category \mathcal{C} is three subcategories of $\text{Map}(\mathcal{C})$ called weak equivalences, cofibrations, and fibrations, and two functorial factorizations (α, β) and (γ, δ) satisfying the following properties :

- (1) (2-out-of-3) If f and g are morphisms of \mathcal{C} such that $g \circ f$ is defined and two of f , g and $g \circ f$ are weak equivalences, then so is the third.
- (2) (Retracts) If f and g are morphisms of \mathcal{C} such that f is a retract of g and g is a weak equivalence, cofibration, or fibration, then so is f .
- (3) (Lifting) Define a map to be a trivial cofibration if it is both a cofibration and a weak equivalence. Similarly, define a map to be a trivial fibration if it is both a fibration and a weak equivalence. Then trivial cofibrations have the LLP with respect to fibrations, and cofibrations have the LLP with respect to trivial fibrations.
- (4) (Factorization) For any morphism f , $\alpha(f)$ is a cofibration, $\beta(f)$ a trivial fibration, $\gamma(f)$ is a trivial cofibration, and $\delta(f)$ is a fibration.

Definition 2.3. [12, 11] A model category is a complete and cocomplete category \mathcal{C} together with a model structure on \mathcal{C} .

Proposition et Definition 2.4. [12, 11] A Quillen adjunction is a pair of adjoint functors $F : \mathcal{C} \rightleftarrows \mathcal{D} : G$ between the model categories \mathcal{C} and \mathcal{D} such that one of the following equivalent properties holds :

- (1) if f is a cofibration (resp. a trivial cofibration), then so does $F(f)$
- (2) if g is a fibration (resp. a trivial fibration), then so does $G(g)$.

One says that F is a left Quillen functor. One says that G is a right Quillen functor.

Definition 2.5. [12, 11] An object X of a model category \mathcal{C} is cofibrant (resp. fibrant) if and only if the canonical morphism $\emptyset \longrightarrow X$ from the initial object of \mathcal{C} to X (resp. the canonical morphism $X \longrightarrow \mathbf{1}$ from X to the final object $\mathbf{1}$) is a cofibration (resp. a fibration).

For any object X of a model category, the canonical morphism $\emptyset_X : \emptyset \longrightarrow X$ from the initial object to X can be factored as a composite

$$\emptyset \xrightarrow{\alpha(\emptyset_X)} Q(X) \xrightarrow{\beta(\emptyset_X)} X$$

where, by definition, $Q(X)$ is a cofibrant object which is weakly equivalent to X . The functor $Q : \mathcal{C} \longrightarrow \mathcal{C}$ is called the *cofibrant replacement functor*.

3. REMINDER ABOUT THE CATEGORY OF FLOWS

In the sequel, any topological space will be supposed to be compactly generated (more details for this kind of topological spaces in [1, 14], the appendix of [13] and also the preliminaries of [3]).

Let $n \geq 1$. Let \mathbf{D}^n be the closed n -dimensional disk. Let $\mathbf{S}^{n-1} = \partial\mathbf{D}^n$ be the boundary of \mathbf{D}^n for $n \geq 1$. Notice that \mathbf{S}^0 is the discrete two-point topological space $\{-1, +1\}$. Let \mathbf{D}^0 be the one-point topological space. Let $\mathbf{S}^{-1} = \emptyset$ be the empty set. The following theorem is well-known.

Theorem 3.1. [11, 12] *The category of compactly generated topological spaces \mathbf{Top} can be given a model structure such that:*

- (1) *The weak equivalences are the weak homotopy equivalences.*
- (2) *The fibrations (sometime called Serre fibrations) are the continuous maps satisfying the RLP (right lifting property) with respect to the continuous maps $\mathbf{D}^n \rightarrow [0, 1] \times \mathbf{D}^n$ such that $x \mapsto (0, x)$ and for $n \geq 0$.*
- (3) *The cofibrations are the continuous maps satisfying the LLP (left lifting property) with respect to any maps satisfying the RLP with respect to the inclusion maps $\mathbf{S}^{n-1} \rightarrow \mathbf{D}^n$.*
- (4) *Any topological space is fibrant.*
- (5) *The homotopy equivalences arising from this model structure coincide with the usual one.*

Definition 3.2. [3] *A flow X consists of a topological space $\mathbb{P}X$, a discrete space X^0 , two continuous maps s and t from $\mathbb{P}X$ to X^0 and a continuous and associative map $*$: $\{(x, y) \in \mathbb{P}X \times \mathbb{P}X; t(x) = s(y)\} \rightarrow \mathbb{P}X$ such that $s(x * y) = s(x)$ and $t(x * y) = t(y)$. A morphism of flows $f : X \rightarrow Y$ consists of a set map $f^0 : X^0 \rightarrow Y^0$ together with a continuous map $\mathbb{P}f : \mathbb{P}X \rightarrow \mathbb{P}Y$ such that $f(s(x)) = s(f(x))$, $f(t(x)) = t(f(x))$ and $f(x * y) = f(x) * f(y)$. The corresponding category will be denoted by \mathbf{Flow} .*

The topological space X^0 is called the 0-skeleton of X . The topological space $\mathbb{P}X$ is called the path space and its elements the non constant execution paths of X . The initial object \emptyset of \mathbf{Flow} is the empty set. The terminal object $\mathbf{1}$ is the flow defined by $\mathbf{1}^0 = \{0\}$, $\mathbb{P}\mathbf{1} = \{u\}$ and necessarily $u * u = u$.

Definition 3.3. [3] *Let Z be a topological space. Then the globe of Z is the flow $\mathbf{Glob}(Z)$ defined as follows: $\mathbf{Glob}(Z)^0 = \{0, 1\}$, $\mathbb{P}\mathbf{Glob}(Z) = Z$, $s = 0$, $t = 1$ and the composition law is trivial.*

Theorem 3.4. [3] *The category of flows can be given a model structure such that:*

- (1) *The weak equivalences are the weak S-homotopy equivalences, that is a morphism of flows $f : X \rightarrow Y$ such that $f : X^0 \rightarrow Y^0$ is an isomorphism of sets and $f : \mathbb{P}X \rightarrow \mathbb{P}Y$ a weak homotopy equivalence of topological spaces.*
- (2) *The fibrations are the continuous maps satisfying the RLP with respect to the morphisms $\mathbf{Glob}(\mathbf{D}^n) \rightarrow \mathbf{Glob}([0, 1] \times \mathbf{D}^n)$ for $n \geq 0$. The fibrations are exactly the morphisms of flows $f : X \rightarrow Y$ such that $\mathbb{P}f : \mathbb{P}X \rightarrow \mathbb{P}Y$ is a Serre fibration of \mathbf{Top} .*
- (3) *The cofibrations are the morphisms satisfying the LLP with respect to any map satisfying the RLP with respect to the morphisms $\mathbf{Glob}(\mathbf{S}^{n-1}) \rightarrow \mathbf{Glob}(\mathbf{D}^n)$ for $n \geq 0$ and with respect to the morphisms $\emptyset \rightarrow \{0\}$ and $\{0, 1\} \rightarrow \{0\}$.*
- (4) *Any flow is fibrant.*

Let I^{gl} be the set of morphisms of flows $\mathbf{Glob}(\mathbf{S}^{n-1}) \rightarrow \mathbf{Glob}(\mathbf{D}^n)$ for $n \geq 0$. Denote by I_+^{gl} be the union of I^{gl} with the two morphisms of flows $R : \{0, 1\} \rightarrow \{0\}$ and $C : \emptyset \subset \{0\}$.

Definition 3.5. [5] *An I_+^{gl} -cell complex is a flow X such that the canonical morphism of flows $\emptyset \rightarrow X$ from the initial object of \mathbf{Flow} to X is a transfinite composition of pushouts of elements of I_+^{gl} . The full and faithful subcategory of \mathbf{Flow} whose objects are the I_+^{gl} -cell complexes will be denoted by $I_+^{gl}\mathbf{cell}$.*

The category $I_+^{gl}\mathbf{cell}$ of I_+^{gl} -cell complexes is a subcategory of the category of flows which is sufficient to model higher dimensional automata (HDA), at least those modeled by precubical sets [9, 2]. This geometric model of HDA is designed to define and study equivalence relations preserving the computer-scientific properties of the HDA to be modeled so that it then suffices to work in convenient localizations of $I_+^{gl}\mathbf{cell}$. The properties which are preserved are for instance the initial or final states, the presence or not of deadlocks and of unreachable states [3].

The cofibrant replacement functor is a functor $Q : \mathbf{Flow} \rightarrow I_+^{gl}\mathbf{cell}$. The flows coming from concrete HDAs are all cofibrant.

4. THE HOMOTOPY BRANCHING SPACE FUNCTOR

The branching space of a flow is the space of germs of non-constant execution paths beginning in the same way. The branching space functor \mathbb{P}^- from the category of flows \mathbf{Flow} to the category of compactly generated topological spaces \mathbf{Top} was also introduced in [3] to fit the definition of the branching semi-globular nerve of a strict globular ω -category modeling an HDA introduced in [6].

Proposition 4.1. [3, 5] *Let X be a flow. There exists a topological space \mathbb{P}^-X unique up to homeomorphism and a continuous map $h^- : \mathbb{P}X \rightarrow \mathbb{P}^-X$ satisfying the following universal property:*

- (1) *For any x and y in $\mathbb{P}X$ such that $t(x) = s(y)$, the equality $h^-(x) = h^-(x * y)$ holds.*
- (2) *Let $\phi : \mathbb{P}X \rightarrow Y$ be a continuous map such that for any x and y of $\mathbb{P}X$ such that $t(x) = s(y)$, the equality $\phi(x) = \phi(x * y)$ holds. Then there exists a unique continuous map $\bar{\phi} : \mathbb{P}^-X \rightarrow Y$ such that $\phi = \bar{\phi} \circ h^-$.*

Moreover, one has the homeomorphism

$$\mathbb{P}^-X \cong \bigsqcup_{\alpha \in X^0} \mathbb{P}_\alpha^-X$$

where $\mathbb{P}_\alpha^-X := h^- \left(\bigsqcup_{\beta \in X^0} \mathbb{P}_{\alpha, \beta}X \right)$. The mapping $X \mapsto \mathbb{P}^-X$ yields a functor \mathbb{P}^- from \mathbf{Flow} to \mathbf{Top} .

Definition 4.2. [3, 5] *Let X be a flow. The topological space \mathbb{P}^-X is called the branching space of the flow X .*

Proposition 4.3. [5] *There exists a weak S -homotopy equivalence of flows $f : X \rightarrow Y$ such that the topological spaces \mathbb{P}^-X and \mathbb{P}^-Y are not weakly homotopy equivalent.*

The idea for the proof of Proposition 4.3 is as follows. For a given flow X , by Proposition 4.1, the topological space \mathbb{P}^-X is the coequalizer of the continuous map $\mathbb{P}X \times_{X^0} \mathbb{P}X \rightarrow \mathbb{P}X$ induced by the composition law of X and of the projection map $\mathbb{P}X \times_{X^0} \mathbb{P}X \rightarrow \mathbb{P}X$

on the first factor. And one cannot expect a coequalizer to transform a objectwise weak homotopy equivalence into a weak homotopy equivalence. One must use a kind of homotopy coequalizer instead.

If two flows are weakly S-homotopy equivalent, then they are supposed to satisfy the same computer-scientific properties. With the example above, one obtains two such flows but with very different branching spaces. But

Theorem 4.4. [5] *If $f : X \rightarrow Y$ is a weak S-homotopy equivalence of flows between cofibrant flows, then the topological spaces \mathbb{P}^-X and \mathbb{P}^-Y are homotopy equivalent.*

This suggests that the definition of the branching space is the good one up to homotopy for cofibrant flows. Indeed, we have the theorems:

Theorem 4.5. [5] *There exists a functor $C^- : \mathbf{Top} \rightarrow \mathbf{Flow}$ such that the pair of functors $\mathbb{P}^- : \mathbf{Flow} \rightleftarrows \mathbf{Top} : C^-$ is a Quillen adjunction. In particular, there is an homeomorphism $\mathbb{P}^-(\varinjlim X_i) \cong \varinjlim \mathbb{P}^-X_i$.*

Definition 4.6. *The homotopy branching space $\text{ho}\mathbb{P}^-X$ of a flow X is by definition the topological space $\mathbb{P}^-Q(X)$.*

Theorem 4.7. [5] *The functor $\text{ho}\mathbb{P}^- : \mathbf{Flow} \rightarrow \mathbf{Top} \rightarrow \mathbf{Ho}(\mathbf{Top})$ satisfies the following universal property: if $F : \mathbf{Flow} \rightarrow \mathbf{Ho}(\mathbf{Top})$ is another functor sending weak S-homotopy equivalences to isomorphisms and if there exists a natural transformation $F \Rightarrow \mathbb{P}^-$, then the latter natural transformation factors uniquely as a composite $F \Rightarrow \text{ho}\mathbb{P}^- \Rightarrow \mathbb{P}^-$.*

Up to homotopy, the homotopy branching space $\text{ho}\mathbb{P}^-(X)$ is well-defined and coincides with \mathbb{P}^-X for any cofibrant flow, so in particular for any flow coming from a HDA. The behavior of the branching space functor and the homotopy branching space functor are the same up to homotopy for flows modeling HDAs and may differ for other flows.

5. THE HOMOTOPY MERGING SPACE FUNCTOR

This is the dual version of the preceding functor. Some results are collected in this section about it.

Proposition 5.1. [5] *Let X be a flow. There exists a topological space \mathbb{P}^+X unique up to homeomorphism and a continuous map $h^+ : \mathbb{P}X \rightarrow \mathbb{P}^+X$ satisfying the following universal property:*

- (1) *For any x and y in $\mathbb{P}X$ such that $t(x) = s(y)$, the equality $h^+(y) = h^+(x * y)$ holds.*
- (2) *Let $\phi : \mathbb{P}X \rightarrow Y$ be a continuous map such that for any x and y of $\mathbb{P}X$ such that $t(x) = s(y)$, the equality $\phi(y) = \phi(x * y)$ holds. Then there exists a unique continuous map $\bar{\phi} : \mathbb{P}^+X \rightarrow Y$ such that $\phi = \bar{\phi} \circ h^+$.*

Moreover, one has the homeomorphism

$$\mathbb{P}^+X \cong \bigsqcup_{\alpha \in X^0} \mathbb{P}_\alpha^+X$$

where $\mathbb{P}_\alpha^+X := h^+\left(\bigsqcup_{\beta \in X^0} \mathbb{P}_{\beta, \alpha}X\right)$. The mapping $X \mapsto \mathbb{P}^+X$ yields a functor $\mathbb{P}^+ : \mathbf{Flow} \rightarrow \mathbf{Top}$.

Definition 5.2. [5] *Let X be a flow. The topological space \mathbb{P}^+X is called the merging space of the flow X .*

Theorem 5.3. [5] *There exists a functor $C^+ : \mathbf{Top} \rightarrow \mathbf{Flow}$ such that the pair of functors $\mathbb{P}^+ : \mathbf{Flow} \rightleftarrows \mathbf{Top} : C^+$ is a Quillen adjunction. In particular, there is an homeomorphism $\mathbb{P}^+(\varinjlim X_i) \cong \varinjlim \mathbb{P}^+ X_i$.*

Definition 5.4. [5] *The homotopy merging space $\mathrm{ho}\mathbb{P}^+ X$ of a flow X is by definition the topological space $\mathbb{P}^+ Q(X)$.*

Theorem 5.5. [5] *The functor $\mathrm{ho}\mathbb{P}^+ : \mathbf{Flow} \rightarrow \mathbf{Top} \rightarrow \mathbf{Ho}(\mathbf{Top})$ satisfies the following universal property: if $F : \mathbf{Flow} \rightarrow \mathbf{Ho}(\mathbf{Top})$ is another functor sending weak S-homotopy equivalences to isomorphisms and if there exists a natural transformation $F \Rightarrow \mathbb{P}^+$, then the latter natural transformation factors uniquely as a composite $F \Rightarrow \mathrm{ho}\mathbb{P}^+ \Rightarrow \mathbb{P}^+$.*

6. FIRST APPLICATION: STUDYING WEAK DIHOMOTOPY

The class \mathcal{S} of weak S-homotopy equivalences is an example of class of morphisms of flows which is supposed to preserve various computer-scientific properties. This class of morphisms of flows satisfies the following properties:

- (1) The two-out-of-three axiom, that is if two of the three morphisms f , g and $g \circ f$ belong to \mathcal{S} , then so does the third one: this condition means that the class \mathcal{S} defines an equivalence relation.
- (2) The embedding functor $I : I_+^{gl} \mathbf{cell} \rightarrow \mathbf{Flow}$ induces a functor $\bar{I} : I_+^{gl} \mathbf{cell}[\mathcal{S}^{-1}] \rightarrow \mathbf{Flow}[\mathcal{S}^{-1}]$ between the localization of respectively the category of I_+^{gl} -cell complexes and the category of flows with respect to weak S-homotopy equivalences which is an equivalence of categories. In particular, it reflects isomorphisms, that is $X \cong Y$ if and only if $\bar{I}(X) \cong \bar{I}(Y)$. In this case, one can use the whole category of flows which is a richer mathematical framework.

The class of T-homotopy equivalences was introduced in [3] to identify I_+^{gl} -cell complexes equivalent from a computer-scientific viewpoint and which are not identified in $I_+^{gl} \mathbf{cell}[\mathcal{S}^{-1}]$. Indeed, if two objects X and Y of $I_+^{gl} \mathbf{cell}[\mathcal{S}^{-1}]$ are isomorphic, then the 0-skeletons X^0 and Y^0 are isomorphic. The merging of the notions of weak S-homotopy equivalence and T-homotopy equivalence yields the class \mathcal{ST}_0 of 0-dihomotopy equivalences.

Definition 6.1. [3] *Let X be a flow. Let A and B be two subsets of X^0 . One says that A is surrounded by B (in X) if for any $\alpha \in A$, either $\alpha \in B$ or there exists execution paths γ_1 and γ_2 of $\mathbb{P}X$ such that $s(\gamma_1) \in B$, $t(\gamma_1) = s(\gamma_2) = \alpha$ and $t(\gamma_2) \in B$. We denote this situation by $A \lll B$.*

Definition 6.2. [3] *Let X be a flow. Let A be a subset of X^0 . Then the restriction $X \downarrow_A$ of X over A is the unique flow such that $(X \downarrow_A)^0 = A$ and*

$$\mathbb{P}(X \downarrow_A) = \bigsqcup_{(\alpha, \beta) \in A \times A} \mathbb{P}_{\alpha, \beta} X$$

equipped with the topology induced by the one of $\mathbb{P}X$.

Definition 6.3. [3] *A morphism of flows $f : X \rightarrow Y$ is a 0-dihomotopy equivalence if and only if the following conditions are satisfied:*

- (1) *The morphism of flows $f : X \rightarrow Y \downarrow_{f(X^0)}$ is a weak S-homotopy equivalence of flows. In particular, the set map $f^0 : X^0 \rightarrow Y^0$ is one-to-one.*
- (2) *For $\alpha \in Y^0 \setminus f(X^0)$, the topological spaces $\mathbb{P}_\alpha^- Y$ and $\mathbb{P}_\alpha^+ Y$ are singletons.*
- (3) *$Y^0 \lll f(X^0)$.*

The class of 0-dihomotopy equivalences is denoted by \mathcal{ST}_0 .

But it turns out that

Theorem 6.4. [5] *The functor $I_+^{gl}\mathbf{cell}[\mathcal{ST}_0^{-1}] \longrightarrow \mathbf{Flow}[\mathcal{ST}_0^{-1}]$ does not reflect isomorphisms. More precisely, there exists an I_+^{gl} -cell complex \vec{C}_3 corresponding to the concurrent execution of three calculations which is not isomorphic in $I_+^{gl}\mathbf{cell}[\mathcal{ST}_0^{-1}]$ to the directed segment \vec{I} , although the same flow \vec{C}_3 is isomorphic to \vec{I} in $\mathbf{Flow}[\mathcal{ST}_0^{-1}]$.*

The correct behavior is the one of \mathcal{ST}_0 in $\mathbf{Flow}[\mathcal{ST}_0^{-1}]$. Indeed, an HDA representing the concurrent execution of n processes must be equivalent to the directed segment in a good homotopical approach of concurrency. The interpretation of this fact is therefore that the class \mathcal{ST}_0 of 0-dihomotopy equivalences is not big enough.

Definition 6.5. [5] *A morphism of flows $f : X \longrightarrow Y$ is a 1-dihomotopy equivalence if and only if the following conditions are satisfied:*

- (1) *The morphism of flows $f : X \longrightarrow Y \downarrow_{f(X^0)}$ is a weak S-homotopy equivalence of flows. In particular, the set map $f^0 : X^0 \longrightarrow Y^0$ is one-to-one.*
- (2) *For $\alpha \in Y^0 \setminus f(X^0)$, the topological spaces $\mathbb{P}_\alpha^- Y$ and $\mathbb{P}_\alpha^+ Y$ are weakly contractible.*
- (3) *$Y^0 \lll f(X^0)$.*

The class of 1-dihomotopy equivalences is denoted by \mathcal{ST}_1 .

Any 0-dihomotopy equivalence is of course a 1-dihomotopy equivalence. Moreover, the composite of a weak S-homotopy equivalence with a T-homotopy equivalence can already give an element of $\mathcal{ST}_1 \setminus \mathcal{ST}_0$! And

Theorem 6.6. [5] *By slightly weakening the notion of T-homotopy as above, one obtains a class of morphisms \mathcal{ST}_1 with $\mathcal{ST}_0 \subset \mathcal{ST}_1$ and such that the flows \vec{C}_3 and \vec{I} become isomorphic in the localization $I_+^{gl}\mathbf{cell}[\mathcal{ST}_1^{-1}]$.*

There are actually two natural ways of weakening the definition of \mathcal{ST}_0 . One can replace in the statement the word *singleton* either by the word *weakly contractible*, or by the word *contractible*. This way, one obtains another class of morphisms \mathcal{ST}'_1 with $\mathcal{ST}'_1 \subset \mathcal{ST}_1$ and one has:

Theorem 6.7. [5] *The localizations $I_+^{gl}\mathbf{cell}[\mathcal{ST}'_1^{-1}]$ and $I_+^{gl}\mathbf{cell}[\mathcal{ST}_1^{-1}]$ are equivalent.*

Unfortunately, one has

Proposition 6.8. [5] *The composite of two morphisms of \mathcal{ST}_1 does not necessarily belong to \mathcal{ST}_1 .*

Using the homotopy branching space functor, a new class \mathcal{ST}_2 of morphisms of flows is introduced.

Definition 6.9. [5] *A morphism of flows $f : X \longrightarrow Y$ is a 2-dihomotopy equivalence if and only if the following conditions are satisfied:*

- (1) *The morphism of flows $f : X \longrightarrow Y \downarrow_{f(X^0)}$ is a weak S-homotopy equivalence of flows. In particular, the set map $f^0 : X^0 \longrightarrow Y^0$ is one-to-one.*
- (2) *For $\alpha \in Y^0 \setminus f(X^0)$, the topological spaces $\mathrm{ho}\mathbb{P}_\alpha^- Y$ and $\mathrm{ho}\mathbb{P}_\alpha^+ Y$ are weakly contractible.*
- (3) *$Y^0 \lll f(X^0)$.*

The class of 2-dihomotopy equivalences is denoted by \mathcal{ST}_2 .

And:

Theorem 6.10. [5] *One has the equivalence of categories*

$$I_+^{gl} \mathbf{cell}[\mathcal{ST}_1^{-1}] \xrightarrow{\simeq} I_+^{gl} \mathbf{cell}[\mathcal{ST}_2^{-1}]$$

where $I_+^{gl} \mathbf{cell}[\mathcal{ST}_1^{-1}]$ (resp. $I_+^{gl} \mathbf{cell}[\mathcal{ST}_2^{-1}]$) is the localization of the category of I_+^{gl} -cell complexes with respect to 1-dihomotopy equivalences (resp. 2-dihomotopy equivalences). \mathcal{ST}_2 is closed under composition. Moreover the embedding functor $I : I_+^{gl} \mathbf{cell} \rightarrow \mathbf{Flow}$ induces an equivalence of categories

$$\bar{I} : I_+^{gl} \mathbf{cell}[\mathcal{ST}_2^{-1}] \xrightarrow{\simeq} \mathbf{Flow}[\mathcal{ST}_2^{-1}].$$

In particular, the functor $I_+^{gl} \mathbf{cell}[\mathcal{ST}_2^{-1}] \rightarrow \mathbf{Flow}[\mathcal{ST}_2^{-1}]$ reflects isomorphisms.

The property $f \in \mathcal{ST}_2$ and $g \circ f \in \mathcal{ST}_2 \implies g \in \mathcal{ST}_2$ has no reasons to be satisfied by 2-dihomotopy equivalences. Indeed, if both $g \circ f$ and f are two one-to-one set maps, then g has no reasons to be one-to-one as well. Therefore in order to understand the isomorphisms of $\mathbf{Flow}[\mathcal{ST}_2^{-1}]$, we may introduce another construction.

Definition 6.11. [5] *Let X be a flow. Then a subset A of X^0 is essential if $X^0 \lll A$ and if for any $\alpha \notin A$, both topological spaces $\mathrm{ho}\mathbb{P}_\alpha^- X$ and $\mathrm{ho}\mathbb{P}_\alpha^+ X$ are weakly contractible.*

Definition 6.12. [5] *A morphism of flows $f : X \rightarrow Y$ is a 3-dihomotopy equivalence if the following conditions are satisfied:*

- (1) $A \subset X^0$ is essential if and only if $f(A) \subset Y^0$ is essential
- (2) for any essential $A \subset X^0$ there exists an essential subset $B \subset A$ such that the restriction $f : X \downarrow_B \rightarrow Y \downarrow_{f(B)}$ is a weak S -homotopy equivalence.

The class of 3-dihomotopy equivalences is denoted by \mathcal{ST}_3 .

Theorem 6.13. [5] *The localizations $I_+^{gl} \mathbf{cell}[\mathcal{ST}_2^{-1}]$ and $I_+^{gl} \mathbf{cell}[\mathcal{ST}_3^{-1}]$ are equivalent and the class of morphisms \mathcal{ST}_3 satisfies the two-out-of-three axiom. Moreover the embedding functor $I : I_+^{gl} \mathbf{cell} \rightarrow \mathbf{Flow}$ induces an equivalence of categories*

$$\bar{I} : I_+^{gl} \mathbf{cell}[\mathcal{ST}_3^{-1}] \xrightarrow{\simeq} \mathbf{Flow}[\mathcal{ST}_3^{-1}].$$

In particular, the functor $I_+^{gl} \mathbf{cell}[\mathcal{ST}_3^{-1}] \rightarrow \mathbf{Flow}[\mathcal{ST}_3^{-1}]$ reflects isomorphisms.

The class \mathcal{ST}_2 does not satisfy the two-out-of-three axiom but is invariant by retract. The class \mathcal{ST}_3 does satisfy the two-out-of-three axiom but is probably not invariant by retract. So none of the definitions above allows to describe the isomorphisms of $I_+^{gl} \mathbf{cell}[\mathcal{ST}_2^{-1}]$. The situation can be summarized with the following diagram:

$$\begin{array}{ccccccc}
 & & & & I_+^{gl} \mathbf{cell} & & \\
 & & & & \downarrow & & \\
 I_+^{gl} \mathbf{cell}[\mathcal{S}^{-1}] & \xrightarrow{\neq} & I_+^{gl} \mathbf{cell}[\mathcal{ST}_0^{-1}] & \xrightarrow{\neq} & I_+^{gl} \mathbf{cell}[\mathcal{ST}_1^{-1}] & \xrightarrow{\simeq} & I_+^{gl} \mathbf{cell}[\mathcal{ST}_2^{-1}] \simeq I_+^{gl} \mathbf{cell}[\mathcal{ST}_3^{-1}] \\
 \simeq \downarrow & & \neq \downarrow & & \simeq?? \downarrow & & \simeq \downarrow \\
 \mathbf{Flow}[\mathcal{S}^{-1}] & \xrightarrow{\neq} & \mathbf{Flow}[\mathcal{ST}_0^{-1}] & \xrightarrow{\simeq??} & \mathbf{Flow}[\mathcal{ST}_1^{-1}] & \xleftarrow{\simeq??} & \mathbf{Flow}[\mathcal{ST}_2^{-1}] \simeq \mathbf{Flow}[\mathcal{ST}_3^{-1}] \\
 & & & & \uparrow & & \\
 & & & & \mathbf{Flow} & &
 \end{array}$$

The symbol $\simeq??$ means that we do not know whether the functor is an equivalence of categories or not. The symbol \neq means that the corresponding functor is not an equivalence.

7. SECOND APPLICATION: A LONG EXACT SEQUENCE FOR THE BRANCHING HOMOLOGY

The category of flows is a simplicial model category [4] in the following sense:

Definition 7.1. [15, 12, 11] *A simplicial model category is a model category \mathcal{C} together with a simplicial set $\text{Map}(X, Y)$ for any object X and Y of \mathcal{C} satisfying the following axioms:*

- (1) *the set $\text{Map}(X, Y)_0$ is canonically isomorphic to $\mathcal{C}(X, Y)$*
- (2) *for any object X, Y and Z , there is a morphism of simplicial sets*

$$\text{Map}(Y, Z) \times \text{Map}(X, Y) \longrightarrow \text{Map}(X, Z)$$

which is associative

- (3) *for any object X of \mathcal{C} and any simplicial set K , there exists an object $X \otimes K$ of \mathcal{C} such that there exists a natural isomorphism of simplicial sets*

$$\text{Map}(X \otimes K, Y) \cong \text{Map}(K, \text{Map}(X, Y))$$

- (4) *for any object X of \mathcal{C} and any simplicial set K , there exists an object X^K such that there exists a natural isomorphism of simplicial sets*

$$\text{Map}(X, Y^K) \cong \text{Map}(K, \text{Map}(X, Y))$$

- (5) *for any cofibration $i : A \longrightarrow B$ and any fibration $p : X \longrightarrow Y$ of \mathcal{C} , the morphism of simplicial sets*

$$Q(i, p) : \text{Map}(B, X) \longrightarrow \text{Map}(A, X) \times_{\text{Map}(A, Y)} \text{Map}(B, Y)$$

is a fibration of simplicial sets. Moreover if either i or p is trivial, then the fibration $Q(i, p)$ is trivial as well.

Recall that there exists a pair of adjoint functors $|-| : \mathbf{SSet} \rightleftarrows \mathbf{Top} : S_*$ where $|-|$ is the geometric realization functor and S_* the singular nerve functor. The n -simplex of \mathbf{SSet} is denoted by $\Delta[n]$. Its boundary is denoted by $\partial\Delta[n-1]$. Let Δ^n be the n -dimensional simplex.

The category of compactly generated topological spaces \mathbf{Top} is a simplicial model category by setting $\text{Map}(X, Y)_n := \mathbf{Top}(X \times \Delta^n, Y)$, $X \otimes K := X \times |K|$ and $X^K := \mathbf{TOP}(|K|, X)$. The category of simplicial sets \mathbf{SSet} is a simplicial model category as well by setting $\text{Map}(X, Y)_n := \mathbf{Top}(X \times \Delta[n], Y)$, $X \otimes K := X \times K$ and $X^K := \text{Map}(K, X)$ [15].

This means that the model category of flows can be enriched over the category of simplicial sets and that the enrichment is compatible with the model structure in the sense of Definition 7.1. The symbol Δ^n is the simplicial set corresponding to the n -dimensional simplex.

Because of the existence of this enrichment, there exist explicit formulae for homotopy colimits [11]. In particular, the homotopy pushout of a diagram of flows looks as follows:

Definition 7.2. [11] *The homotopy pushout of the diagram of flows*

$$\begin{array}{ccc} A & \longrightarrow & B \\ \downarrow & & \\ & & C \end{array}$$

is the colimit of the diagram of flows

$$\begin{array}{ccc}
 & A \otimes \Delta^0 & \longrightarrow B \\
 & \downarrow & \\
 A \otimes \Delta^0 & \longrightarrow & A \otimes \Delta^1 \\
 \downarrow & & \\
 C & &
 \end{array}$$

It is then very easy to prove the:

Theorem 7.3. [4] *Let X be a diagram of flows. Then the topological spaces $\underline{\text{holim}} \text{hoP}^-(X)$ and $\text{hoP}^-(\underline{\text{holim}} X)$ are homotopy equivalent (they are both cofibrant indeed). So in particular, the homotopy branching space functor commutes with homotopy pushouts.*

Definition 7.4. [4] *Let $f : X \longrightarrow Y$ be a morphism of flows. The cone Cf of f is the homotopy pushout in the category of flows*

$$\begin{array}{ccc}
 X & \xrightarrow{f} & Y \\
 \downarrow & & \downarrow \\
 \mathbf{1} & \longrightarrow & Cf
 \end{array}$$

where $\mathbf{1}$ is the terminal flow.

From the theorem

Theorem 7.5. [4] *The homotopy branching space of the terminal flow is contractible.*

one can easily deduce a long exact sequence for the branching homology.

Definition 7.6. [4] *Let X be a flow. Then the $(n+1)$ st branching homology group $H_{n+1}^-(X)$ is defined as the n st homology group of the augmented simplicial set $\mathcal{N}_*^-(X)$ defined as follows:*

- (1) $\mathcal{N}_n^-(X) = S_n(\text{hoP}^- X)$ for $n \geq 0$
- (2) $\mathcal{N}_{-1}^-(X) = X^0$
- (3) the augmentation map $\epsilon : S_0(\text{hoP}^- X) \longrightarrow X^0$ is induced by the mapping $\gamma \mapsto s(\gamma)$ from $\text{hoP}^- X = S_0(\text{hoP}^- X)$ to X^0 .

Theorem 7.7. [4] *For any flow X , one has*

- (1) $H_0^-(X) = \mathbb{Z}X^0 / \text{Im}(s)$
- (2) the short exact sequence $0 \rightarrow H_1^-(X) \rightarrow H_0(\text{hoP}^- X) \rightarrow \mathbb{Z} \text{hoP}^- X / \text{Ker}(s) \rightarrow 0$
- (3) $H_{n+1}^-(X) = H_n(\text{hoP}^- X)$ for $n \geq 1$.

Theorem 7.8. [4] *For any morphism of flows $f : X \longrightarrow Y$, one has the long exact sequence*

$$\begin{aligned}
 \cdots &\rightarrow H_n^-(X) \rightarrow H_n^-(Y) \rightarrow H_n^-(Cf) \rightarrow \cdots \\
 \cdots &\rightarrow H_3^-(X) \rightarrow H_3^-(Y) \rightarrow H_3^-(Cf) \rightarrow \\
 &H_2^-(X) \rightarrow H_2^-(Y) \rightarrow H_2^-(Cf) \rightarrow \\
 &H_0(\text{hoP}^- X) \rightarrow H_0(\text{hoP}^- Y) \rightarrow H_0(\text{hoP}^- Cf) \rightarrow 0.
 \end{aligned}$$

The functors $X \mapsto H_n^-(X)$ for $n \geq 0$ are invariant up to 2-dihomotopy equivalence. The functor $X \mapsto H_0(\text{hoP}^- X)$ is only invariant up to weak S-homotopy equivalence. So the long exact sequence above is not satisfactory. It still remains to find an exact sequence whose each term would be a functor invariant up to 2-dihomotopy equivalence.

REFERENCES

- [1] R. Brown. *Topology*. Ellis Horwood Ltd., Chichester, second edition, 1988. A geometric account of general topology, homotopy types and the fundamental groupoid.
- [2] R. Cridlig. Implementing a static analyzer of concurrent programs: Problems and perspectives. In *Logical and Operational Methods in the Analysis of Programs and Systems*, pages 244–259, 1996.
- [3] P. Gaucher. A Convenient Category for The Homotopy Theory of Concurrency. arXiv:math.AT/0201252.
- [4] P. Gaucher. A long exact sequence for the branching homology. arXiv:math.AT/0305169.
- [5] P. Gaucher. Homotopy branching space and weak dihomotopy. arXiv:math.AT/0304112.
- [6] P. Gaucher. The branching nerve of HDA and the Kan condition. *Theory and Applications of Categories*, 11(3):pp.75–106, 2003.
- [7] P. Gaucher. Concurrent process up to homotopy (I). *C. R. Acad. Sci. Paris Ser. I Math.*, 336(7):593–596, 2003. French.
- [8] P. Gaucher. Concurrent process up to homotopy (II). *C. R. Acad. Sci. Paris Ser. I Math.*, 336(8):647–650, 2003. French.
- [9] P. Gaucher and E. Goubault. Topological deformation of higher dimensional automata. *Homology, Homotopy and Applications*, 5(2):p.39–82, 2003.
- [10] E. Goubault. Some geometric perspectives in concurrency theory. *Homology, Homotopy and Applications*, 5(2):p.95–136, 2003.
- [11] P. S. Hirschhorn. *Model categories and their localizations*, volume 99 of *Mathematical Surveys and Monographs*. American Mathematical Society, Providence, RI, 2003.
- [12] M. Hovey. *Model categories*. American Mathematical Society, Providence, RI, 1999.
- [13] L. G. Lewis. *The stable category and generalized Thom spectra*. PhD thesis, University of Chicago, 1978.
- [14] J. P. May. *A concise course in algebraic topology*. University of Chicago Press, Chicago, IL, 1999.
- [15] D. G. Quillen. *Homotopical algebra*. Lecture Notes in Mathematics, No. 43. Springer-Verlag, Berlin, 1967.

INSTITUT DE RECHERCHE MATHÉMATIQUE AVANCÉE, ULP ET CNRS, 7 RUE RENÉ-DESCARTES, 67084 STRASBOURG CEDEX, FRANCE

E-mail address: gaucher@math.u-strasbg.fr

URL: <http://www-irma.u-strasbg.fr/~gaucher/>

Simulations as Homotopies

K. Hess,* P-E. Parent,† A. Tonks,‡ K. Worytkiewicz

27th July 2003

Abstract

We exhibit a model structure on **2-Cat**, obtained by transfer from **SSet** across the adjunction $C_2 \text{ } Sd^2 \dashv Ex^2 \text{ } N_2$. A certain class of homotopies in this model structure turns out to be in 1-to-1 correspondence with strong simulations among labeled transitions systems, formalising the geometric intuition of simulations as deformations. We comment on potential applications of obstruction theory.

1 Introduction

This work is part of an investigation exploring the potential of algebraic-topological techniques in classical concurrency theory, a particularly interesting area of algebraic topology in this respect being certainly *obstruction theory*. However, before being in position to apply (an appropriate version of) the latter, a fundamental question to address is how to transfer basic notions like homotopy to the realm of concurrency theory.

For concreteness, we focus here on *labeled transition systems* (cf. [7]). The latter have been extensively studied from a categorical angle (cf. for instance [6]), so which category and which model structure (cf. [8]) for *homotopies of labeled transition systems*? The present account is based on our recent discovery of a model structure on the category **2-Cat**. The associated notion of homotopy then agrees on relevant instances with a specific yet less widespread characterisation of simulation (cf. [4]).

*EPFL

†EPFL

‡London Metropolitan

2 A Thomason Model Structure on 2-Cat

Definition 2.1. Let \mathcal{A} and \mathcal{B} be 2-categories s.t. $\mathcal{A} \hookrightarrow \mathcal{B}$. \mathcal{A} is a 2-sieve if for any $a \in \mathcal{A}$

- (i) $\forall f \in \mathcal{B}_1 \text{ cod}(f) = a \Rightarrow f \in \mathcal{A}_1$;
- (ii) $\forall \alpha \in \mathcal{B}_2 \text{ (cod } \text{ dom)}(\alpha) = (\text{cod } \text{ cod})(\alpha) = a \Rightarrow \alpha \in \mathcal{A}_2$.

2-cosieves are defined dually.

Definition 2.2. Let $\mathbf{2-Cat}_{lax, norm}$ be the category of 2-categories and normal lax functors. Let \mathcal{A} and \mathcal{B} be 2-categories. An inclusion $i : \mathcal{A} \hookrightarrow \mathcal{B}$ is a weak immersion if

- (i) \mathcal{A} is a 2-sieve;
- (ii) there is a 2-cosieve \mathcal{W} such that $\mathcal{A} \hookrightarrow \mathcal{W} \hookrightarrow \mathcal{B}$;
- (iii) $i : \mathcal{A} \hookrightarrow \mathcal{W}$ admits a retraction r ;
- (iv) there is a normal lax functor $\varepsilon : [1] \times \mathcal{W} \rightarrow \mathcal{W}$ such that

$$\begin{array}{ccc}
 \mathcal{W} & \xrightarrow{i_0} [1] \times \mathcal{W} & \xleftarrow{i_1} \mathcal{W} \\
 & \searrow id_{\mathcal{W}} & \downarrow \varepsilon \\
 & & \mathcal{W}
 \end{array}$$

commutes in $\mathbf{2-Cat}_{lax, norm}$ and further that $\varepsilon|_{[1] \times \mathcal{A}}$ is strict and that $\varepsilon(0, 1, id_a) = id_a$ for all $a \in \mathcal{A}$.

Proposition 2.1. Let $\mathbf{SSet} \stackrel{def}{=} \mathbf{Set}^{\Delta^{op}}$ be the category of simplicial sets. The 2-nerve $N_2 : \mathbf{2-Cat} \rightarrow \mathbf{SSet}$ is given on a 2-category \mathcal{A} in dimension n by the set of normal lax functors $N_2(\mathcal{A})_n \stackrel{def}{=} Lax_{norm}([n], \mathcal{A})$ and on 2-functors $\mathcal{A} \rightarrow \mathcal{B}$ by postcomposition. We have an adjunction $C_2 \dashv N_2$.

Proposition 2.1 essentially stems from Ross Street's work (cf. [9]).

Lemma 2.1. The image under N_2 of a pushout square of a weak immersion along an arbitrary 2-functor is a homotopy pushout square.

Definition 2.3. Let \mathbb{M} be a model category and $L \dashv R : \mathbb{M} \rightarrow \mathbb{C}$ be an adjunction. R creates a model structure on \mathbb{C} if there is a model structure on \mathbb{C} such that $fib_{\mathbb{C}} = R^{-1}(fib_{\mathbb{M}})$ and $weq_{\mathbb{C}} = R^{-1}(weq_{\mathbb{M}})$.

Proposition 2.2. *Let \mathbb{M} be a co-brantly generated model category with J the set of generating acyclic cofibrations and $L \dashv R : \mathbb{M} \rightarrow \mathbb{C}$ be an adjunction with \mathbb{C} a locally presentable category. Suppose further that*

- (i) *R preserves filtered colimits;*
- (ii) *for any $f \in J$ and for any pushout g of $L(f)$, $R(g)$ is a weak equivalence.*

Then R creates a co-brantly generated model structure on \mathbb{C} .

Proposition 2.2 is due to Tibor Beke (cf. [1] where a more general version is to be found).

Theorem 2.1. *Ex^2 N_2 creates a model structure on 2-Cat .*

Proof. It is well-known that 2-Cat is finitely presentable and that Ex preserves filtered colimits. It is easy to see that N_2 preserves filtered colimits, so it remains to establish condition (ii) of proposition 2.2.

Let $i_{k,n} : \Lambda^k[n] \hookrightarrow \Delta[n]$ be a horn inclusion. It can be shown that $C_2(Sd^2(i_{k,n}))$ is a weak immersion and that $N_2C_2(Sd^2(i_{k,n}))$ is a weak equivalence in \mathbf{SSet} , so the assertion follows from lemma 2.1 by 2-of-3. \square

Clearly, lemma 2.1 is the "working horse" here. It is easy to see that the resulting structure is left-proper. We call it *Thomason model structure* since it is conceptually similar to a model structure on \mathbf{Cat} due to R.W.Thomason (cf. [10]).

3 Strong Simulations as Homotopies

Observe that the traditional presentation of a labeled transition system¹ $\mathbf{S} = (\rightarrow S \Sigma S)$ amounts to an indexed set of relations $(\rightarrow^\alpha S S)_{\alpha \in \Sigma}$ so by adjunction to a functor $\bar{\mathbf{S}} : \Sigma^* \rightarrow \mathbf{Rel}(S, S)$ which can also be seen as a 2-functor $\bar{\mathbf{S}} : \Sigma^* \rightarrow \mathbf{Rel}$. Let $\mathbf{S}' = (\rightarrow S' \Sigma S')$ be a further transition system. A simulation abusively written $\mathbf{S} \rightsquigarrow \mathbf{S}'$ is a relation $\sigma : S \rightsquigarrow S'$ s.t.

$$\forall \alpha \in \Sigma. x \sigma x' \wedge \exists y \in S. x \rightarrow^\alpha y \Rightarrow \exists y' \in S'. x' \rightarrow'^\alpha y' \wedge y \sigma y'$$

This condition is equivalent to

$$\forall \alpha \in \Sigma. \rightarrow^\alpha \sigma^{op} \sigma^{op} \rightarrow'^\alpha \quad (*)$$

¹The usual definition of a transition system also includes an initial state *i.e.* it is a *pointed* version of the one below. We do not address this issue throughout this section in order not to clutter the exposition, since everything (in this section) carries over to the pointed case.

Proposition 3.1. *Let \mathcal{A} be a 2-category. Let $\text{Cyl}(\mathcal{A})$ be the bicategory of cylinders (cf. [2]) over \mathcal{A} and $\mathfrak{P} : \text{Cyl}(\mathcal{A}) \rightarrow \mathcal{A}$ the associated homomorphism. $\text{Cyl}(\mathcal{A})$ is a 2-category and \mathfrak{P} is a 2-functor. Moreover, if \mathcal{A} has a 2-terminal object, $\text{Cyl}(\mathcal{A})$ is a path object in the Thomason model structure.*

Theorem 3.1. *Let \mathbf{S} and \mathbf{T} be transition systems. Under the notation of proposition 3.1, the following are equivalent*

- (i) *there is a simulation $\mathbf{S} \rightarrow \mathbf{T}$;*
- (ii) *the 2-functor $\langle \overline{\mathbf{T}}, \overline{\mathbf{S}} \rangle$ factors through \mathfrak{P} ;*
- (iii) *there is a lax transformation $\overline{\mathbf{T}} \Rightarrow \overline{\mathbf{S}}$;*
- (iv) *there is a homotopy $\overline{\mathbf{T}} \rightsquigarrow \overline{\mathbf{S}}$ in the Thomason model structure.*

Proof. The equivalence (ii) \Leftrightarrow (iii) is inherent to Jean Benabou's work (cf. [2]), (i) \Leftrightarrow (ii) was first noticed by Claudio Hermida and follows from (*) above (cf. [4]) while (ii) \Leftrightarrow (iv) follows from proposition 3.1. \square

4 Obstructions

Given transition systems \mathbf{S} and \mathbf{T} , it is at any rate sensible to ask if there is a simulation. A specific instance is of particular interest: as Hermida recently put forward (cf. [5]), it is the case that given \mathbf{S} and a relational modal formula ϕ , the truth of $\mathbf{S} \models \phi$ amounts to a simulation $\mathbf{S} \rightarrow \Phi$ where Φ is a transition system built from ϕ . Hence, by theorem 3.1, it amounts to a homotopy $\overline{\Phi} \rightsquigarrow \overline{\mathbf{S}}$, so looking for an obstruction can be assimilated to *model-checking*.

It is easy to see that \mathfrak{P} above is not a fibration in the Thomason model structure, so its fibred replacement with a *very good* cylinder object is required in order to formulate the relevant lifting problem. What remains to do is to develop an appropriate obstruction theory. There has been some work in this direction by Dwyer *et.al.* (cf. [3]) but their notion of obstruction is too coarse to be used in this context.

A good notion of obstruction is subject of an ongoing investigation. The future will show if any of this turns out to be of relevance for program verification, in particular the setup should then accommodate λ -points *i.e.* the modal logic should be able to handle the expressiveness of a modal μ -calculus. Nevertheless, we believe that this line of research might very well lead to new insights and techniques.

References

- [1] Tibor Beke. Sheafable homotopy model categories, part ii. *Journal of Pure and Applied Algebra*, 164(3):307–324, 2001.
- [2] Jean Benabou. *Introduction to Bicategories*, volume 47 of *Lecture Notes in Mathematics*. Springer, 1967.
- [3] William Dwyer, Daniel Christensen, and Daniel Isaksen. Obstruction theory in model categories. Preprint (Notre Dame), 2001.
- [4] Claudio Hermida. Simulations as modules. Unpublished, 1997.
- [5] Claudio Hermida. A categorical outlook on relational modalities and simulations. Presented at IMLA'02, July 2002.
- [6] Andre Joyal, Mogens Nielsen, and Glynn Winskel. Bisimulation and open maps. *Information and Computation*, 127, 1996.
- [7] Robin Milner. *Communication and Concurrency*. Prentice Hall, 1989.
- [8] Daniel Quillen. *Homotopical Algebra*, volume 43. Springer, 1967.
- [9] Ross Street. The algebra of oriented simplexes. *J. Pure Appl. Algebra*, 49:283–335, 1987.
- [10] Robert W. Thomason. Cat as a closed model category. *Cahiers de Topologie et Géométrie Différentielle*, 21(3):305–324, 1980.

Oriented Combinatorial Topology and Concurrency^{*}

Michael Johnson

*Departments of Mathematics and Computer Science
Macquarie University
Sydney, Australia*

Dominic Verity

*Division of Information and Communication Sciences
Macquarie University
Sydney, Australia*

Abstract

Higher dimensional automata (HDA) provide valuable models of concurrent processes. Much current research related to HDA aims to further develop algebraic topological notions required to analyse HDA in order to determine computer scientific properties including deadlock, safety, unreachable states, etc. It is well-known that classical algebraic topology will not suffice since the sequences of actions represented by (1-dimensional) paths need to be monotone with respect to a multi-dimensional coordinate system (the coordinate system might be thought of as time, or its coordinates can be thought of separately as progress with respect to particular processes). The extent to which higher dimensional paths inherit an orientation as a result of either the coordinate system, or the definition of homotopy, varies according to the precise notions of directed algebraic topology that are utilised. This paper considers an extreme position in which all higher dimensional paths, like 1-dimensional paths, are oriented and can only be composed when orientations are compatible. This point of view has arisen both from software engineering considerations and from considerations of the history of classical combinatorial topology.

1 Introduction

When Vaughan Pratt first introduced higher dimensional automata (drafts of [19]) the higher dimensional cells were all oriented and although cells were cubical the underlying graphical structures were general pasting schemes [17].

^{*} Research partially supported by the Australian Research Council and an MURDG.

More recently, following the seminal work of Goubault [10], HDA have been studied extensively. Significant progress has been attained in further work by Goubault and coauthors, for example [13] and [12], in a series of papers by Gaucher [5], [6], [7], [8], [9] and in work by Fajstrup [4], Grandis [14], [15], [16] and Raussen [21], [22] amongst others. The HDA have variously been based upon n -categories [19], cubical complexes [20], and pasting schemes [6]. Nevertheless, the bulk of the work explores homotopies between oriented paths in an ambient unoriented space.

In this paper we discuss some advantages of using combinatorial topology with oriented n -cells of arbitrary shape. The underlying graphical structure that we use was introduced by Buckland-Johnson-Verity [3], and was designed to support explicit choice higher dimensional automata (ECHDA)¹ which were first proposed in [1] and were further developed in [2].

In the full paper we discuss

- (i) The introduction of oriented higher dimensional cells in the foundation of algebraic topology and the effect it had on clarifying the subject (leading to the study of simplicial objects in general, and to the widespread use of the singular homology for example)
- (ii) How the analogous introduction of oriented higher dimensional cells in a geometric representation of concurrent processes can be interpreted
- (iii) The software engineering advantages that might be expected from serious development of the oriented higher dimensional approach to HDA

Most importantly, we trace through several detailed examples showing the interaction of concurrency and choice in ECHDA. These illustrate the expected software engineering examples, as well as clarifying the oriented higher dimensional approach.

2 Structure

The full paper has, after the introduction, five sections which cover

- (i) Historical remarks on oriented combinatorial topology
- (ii) A proposal for the analogous treatment of HDA with remarks about the software engineering advantages of taking this approach
- (iii) A definition of ECHDA. ECHDA are one possible approach to oriented combinatorial HDA
- (iv) Examples
- (v) A discussion of free constructions.

¹ ECHDA is a plural abbreviation. When we need to refer to an explicit choice higher dimensional automaton we will call it an ECHDon.

Here we will make no further remarks about any except the last of these, but free constructions do warrant some further explanation.

3 Free constructions

It might be argued that HDA are already “oriented”. Does not providing an order on 1-dimensional paths correspond to an order on the vertices of a simplex?

This is certainly true, but it does not suffice for the analogy being explored in this paper. The singular complex of a space is a canonical representation of its structure because it is the free simplicial object on the space (calculated in the sense of [18]). Similarly, the collection of paths (of arbitrary dimension) in an ECHDon ought to carry the structure of the free ω -category on the ECHDon.

We explain this in further detail in the final section of the paper, and discuss its software engineering implications: A path (of arbitrary dimension) in an ECHDon represents a process obtained by partial evaluation within the process represented by the ECHDon. The partial evaluation may be with respect to values of variables or choices (as in common applications of partial evaluation in computer science), or it may be with respect to concurrency or scheduling.

References

- [1] R. Buckland, Choice as a first class citizen, in *Intensional Programming I*, eds Orgun and Ashcroft, (1996) 249–259, World Scientific.
- [2] R. Buckland and M. Johnson, ECHIDNA: A system for manipulating explicit choice higher dimensional automata, *AMAST’96, Lecture Notes in Computer Science* **1101** (1996) 587–591.
- [3] R. Buckland, M. Johnson and D. Verity, On the specification of Higher Dimensional Automata. *ENTCS*, **68**, 1, (2002) 1–13.
- [4] L. Fajstrup, Loops, ditopology and deadlocks. *Mathematical Structures in Computer Science* **10** (2000) 459–480.
- [5] P. Gaucher, From concurrency to algebraic topology, *ENTCS*, **39** (2000).
- [6] P. Gaucher, Homotopy invariants of higher dimensional categories and concurrency in computer science, *Mathematical Structures in Computer Science*, **10** (2000) 481–524.
- [7] P. Gaucher, Combinatorics of branchings in higher dimensional automata, *Theory and Applications of Categories*, **8** (2001) 324–376.
- [8] P. Gaucher, Investigating the algebraic structure of dihomotopy types, *ENTCS*, **52** number 2, to appear.
- [9] P. Gaucher, About the globular homology of higher dimensional automata, *Cahiers de Topologie et Geometrie Differentielle Categorique*, (2002), to appear.

- [10] E. Goubault, The Geometry of Concurrency, PhD thesis, ENS, 1995.
- [11] E. Goubault (ed), Geometry and concurrency, special issue of *Mathematical Structures in Computer Science* **10** (2000) 409–573.
- [12] E. Goubault, L. Fajstrup and M. Raussen, Detecting Deadlocks in Concurrent Systems, CONCUR’98 Lecture Notes in Computer Science **1466** (1998) 332–347.
- [13] E. Goubault and M. Raussen, Dihomotopy as a tool in state space analysis, LATIN’02, Lecture notes in Computer Science **2286** (2002) 16–37.
- [14] M. Grandis, Directed homotopy theory I: The fundamental category, to appear in *Cahiers de Topologie et Géométrie Catégoriques*.
- [15] M. Grandis, Directed homotopy theory II: Homotopy constructs, *Theory and Application of Categories* **10** (2002) 369–391.
- [16] M. Grandis, Directed combinatorial homology and noncommutative tori (the breaking of symmetries in algebraic topology), Preprint, 2003.
- [17] M. Johnson, The combinatorics of n -categorical pasting, *Journal of Pure and Applied Algebra* **62** (1989) 211–225.
- [18] M. Johnson and R. Walters, Algebra objects and algebra families for finite limit theories, *Journal of Pure and Applied Algebra* **83** (1992) 283–293.
- [19] V. Pratt, Modelling concurrency with geometry, *Proceedings of POPL 18*, ACM Press, (1991) 311–322.
- [20] V. Pratt, Transition and cancellation in concurrency and branching time, *Mathematical Structures in Computer Science* (2002) to appear.
- [21] M. Raussen, On the classification of dipaths in geometric models for concurrency, *Mathematical Structures in Computer Science* **10** (2000) 427–457.
- [22] M. Raussen, State spaces and dipaths up to dihomotopy, *Homotopy, Homology and Applications* **5** (2003) 257–280.

Recent BRICS Notes Series Publications

- NS-03-1 Patrick Cousot, Lisbeth Fajstrup, Eric Goubault, Maurice Herlihy, Kurtz Alexander, Martin Raußen, and Vladimiro Sassone, editors. *Preliminary Proceedings of the Workshop on Geometry and Topology in Concurrency Theory, GETCO '03*, (Marseille, France, September 6, 2003), August 2002. vi+50.
- NS-02-8 Peter D. Mosses, editor. *Proceedings of the Fourth International Workshop on Action Semantics, AS 2002*, (Copenhagen, Denmark, July 21, 2002), December 2002. vi+133 pp.
- NS-02-7 Anders Møller. *Document Structure Description 2.0*. December 2002. 29 pp.
- NS-02-6 Aske Simon Christensen and Anders Møller. *JWIG User Manual*. October 2002. 35 pp.
- NS-02-5 Patrick Cousot, Lisbeth Fajstrup, Eric Goubault, Maurice Herlihy, Martin Raußen, and Vladimiro Sassone, editors. *Preliminary Proceedings of the Workshop on Geometry and Topology in Concurrency Theory, GETCO '02*, (Toulouse, France, October 30–31, 2002), October 2002. vi+97.
- NS-02-4 Daniel Gudbjartsson, Anna Ingólfssdóttir, and Augustin Kong. *An BDD-Based Implementation of the Allegro Software*. August 2002. 2 pp.
- NS-02-3 Walter Vogler and Kim G. Larsen, editors. *Preliminary Proceedings of the 3rd International Workshop on Models for Time-Critical Systems, MTCS '02*, (Brno, Czech Republic, August 24, 2002), August 2002. vi+141 pp.
- NS-02-2 Zoltán Ésik and Anna Ingólfssdóttir, editors. *Preliminary Proceedings of the Workshop on Fixed Points in Computer Science, FICS '02*, (Copenhagen, Denmark, July 20 and 21, 2002), June 2002. iv+81 pp.
- NS-02-1 Anders Møller and Michael I. Schwartzbach. *Interactive Web Services with Java: JSP, Servlets, and JWIG*. April 2002. 99 pp.
- NS-01-8 Anders Møller and Michael I. Schwartzbach. *The XML Revolution (Revised)*. December 2001. 186 pp. This revised and extended report supersedes the earlier BRICS Report NS-00-8.