



Operational Semantics for MSC'96

S. Mauw^a, M.A. Reniers^a

^a *Department of Computing Science, Eindhoven University of Technology, P.O. Box 513, NL-5600 MB Eindhoven, Netherlands*

Abstract

Recently, the ITU-standardised specification language Message Sequence Chart has been extended with constructs for more complete and structured specifications. The new version of the language is called MSC'96. Currently, research is performed on the extension of the formal semantics towards a semantics for MSC'96. In this article, we aim at explaining the basic ideas behind the formal semantics. We give formal definitions of parts of the language, but most features are explained by informal examples and drawings. It takes several steps in order to follow the path from an MSC drawing to its formal meaning. First, the drawing must be converted to a concrete textual representation. This conversion is already defined implicitly in Z.120. Next, this syntax is transformed into a formal expression over some process algebra signature. MSC constructs are replaced by appropriate process algebra operators. This transformation is compositional. The operational behaviour of the process algebraic expression can be studied, or the expression can be interpreted into some mathematical model and compared to the interpretation of some other MSC. © 1999 Elsevier Science B.V. All rights reserved.

Keywords: Message Sequence Chart; Operational semantics; Composition; Standardisation

1. Introduction

Recently, the specification language Message Sequence Chart (MSC) [16], which is standardised by the International Telecommunication Union (ITU), has been extended with constructs for more complete and structured specifications. The new version of the language is called MSC'96. Currently, research is performed on the extension of the formal semantics towards a semantics for MSC'96. In this article, we describe the basics of the upcoming formal semantics definition of MSC'96. We expect that the formal semantics will be accepted by the ITU as Annex B to Recommendation Z.120 in 1998.

Ideally, the development of a language and its semantics should go hand in hand. There is little use in defining a fancy syntactic construction without a

precise understanding of its meaning. As was the case for the previous version of the MSC language, first the syntax and an incomplete and informal semantics were developed, while the construction of a formal semantics was deferred until after the acceptance of the language by the ITU-bodies. It is obvious that the a posteriori construction of a formal semantics will reveal many places in which the informal language description is ambiguous, under-specified, inconsistent or suboptimal. In Ref. [18] a number of such situations is described.

Nevertheless, there are also parts of MSC'96 that can be understood unambiguously. These include the parts of MSC'96 which are already covered by the old formal semantics. But, also the extension of the language with explicit and implicit operators for composing MSCs can be understood clearly.

The purpose of this article is not to give a complete semantics definition of MSC'96. For this, we refer to the (upcoming) revision of Annex B to Recommendation Z.120. We only aim at explaining the basic ideas behind the formal semantics. We give formal definitions of parts of the language, but most features are explained by informal examples and drawings. As the semantics are currently still under development, details may change. However, we expect that the basic ideas of the chosen approach remain stable.

The semantics proposed for standardisation are very much an extension of the previous formal semantics [22,15,20]. There are some differences, though. First, we have slightly changed the set of basic operators, such that it yields a smoother definition. Second, rather than giving a sound and complete process algebraic specification by means of axioms, we provide for an operational semantics based on process algebra expressions, only. The main reason is that we expect that a complete axiomatisation of all constructs involved is not feasible. This is mainly due to the extension towards infinite behaviour. The consequence of using an operational semantics is that we do not longer have the ability of equational reasoning. The equality of MSCs is now defined in a mathematical model, rather than by axioms.

Nevertheless, it is possible to define a sufficient number of sound equations which only fail in covering a few constructs completely. Although an important topic for research, we think that an incomplete set of axioms should not be part of the recommended semantics.

It takes several steps in order to follow the path from an MSC drawing to its formal meaning. First, the drawing must be converted to a concrete textual representation. This conversion is already defined implicitly in Z.120. Next, this syntax is transformed into a formal expression over some process algebra signature. MSC constructs are replaced by appropriate process algebra operators. This transformation is compositional, in the sense that first the transformation of simple constructs can be determined, while the transformation of a complex construct is defined in terms of the transformations of the simple constructs. Finally, the operational behaviour of the process algebraic expression can be studied, or the

expression can be interpreted into some mathematical model and compared to the interpretation of some other MSC.

In this article, we focus on the definition of the process algebraic expressions and their operational meanings. This article is structured as follows. In Section 2 we give a short overview of the MSC'96 language. We make a distinction between *events*, constructs for *ordering* and constructs for *design*. In Section 3 we explain process algebraic expressions and operators and we discuss the transformation of an MSC into such an expression. In Section 4 we explain the operational semantics of some of the process algebraic operators needed.

2. MSC'96

The previous version of the MSC language, MSC'93 [14], was developed to express behavioural traces of distributed systems. It has primitives for denoting objects (*instances*) and for describing the relative order of messages exchanged between these objects. Furthermore, it has some more specific features, such as instance creation and timers. A specification consists of a series of MSCs, each describing a scenario. So-called *conditions* were used to guide the user through a specification.

Experience gained over the past few years, in which the use of the language increased, has shown that the language MSC'93 lacks the means to structure larger MSCs and to define the relation between simple MSCs. Therefore, most of the new features from MSC'96 deal with composition. Several important aspects have not been covered in MSC'96. These are amongst others time, data, probabilities and more specialised operators such as interrupts and disrupts. These are subject to further research.

In this section, we give an overview of MSC'96, based on the viewpoint that all features fit in one of the three categories: *event*, *ordering*, *design*. We use these categories because the constructs within such a category are treated similarly in the definition of the semantics (see Section 3).

It is assumed that the reader has (at least) a basic knowledge of the language MSC'93. For a comprehensive treatment of the complete MSC'96 language we refer to [11]. An introduction to MSC'96 is [28].

2.1. Events

An *event* is the basic unit of observation. It models a part of the system's behaviour which is considered as one indivisible action. In MSC'96 we find the following events: *local actions*, message events (i.e. *sending* a message, *receiving* a message, a *lost message* and a *found message*), *creation* and *termination* of an instance, and timer events (i.e. *set*, *reset* and *time-out*). The only new events are lost and found messages.

2.2. Ordering

An MSC is used to express the relative *ordering* of the events contained. The main source of order is the *instance*. In general, the events attached to an instance axis are in a strict sequential order. This order can be relaxed by the *coregion* construct. Events within a coregion may occur in any order. A basic assumption of the semantics of MSC is the requirement that in an MSC the sending of a message always precedes the corresponding reception. This ordering is referred to as the *message ordering*. These three means to describe ordering are already present in MSC'93.

MSC'96 extends MSC'93 with the *causal ordering* construct. By means of an arrow with the arrow-

head in the middle events can be ordered causally. This feature allows for the description of ordering between events from different instances, as well as the description of ordering on events from one instance. In combination with the coregion construct, this makes it possible to express arbitrary partial orders on the events in a coregion.

2.3. Design

Several techniques have been introduced to support the modular *design* of specifications in a top-down or bottom-up manner. First, *High-level MSCs* (HMSC) [24] are used to indicate the relation between different smaller MSCs. In an HMSC one can express parallelism, sequencing, alternatives and recursion. HMSCs are the synthesis of the roadmap approach [13] and the operator approach [10]. As such, they replace the informal use of roadmaps for overview specification.

With *MSC reference expressions* one is able to abstract from the actual contents of an MSC. In an MSC, references to other MSCs may be included, combined by several operators. A *substitution* mechanism is included which supports the reuse of modular specifications. Furthermore, the interface between an MSC reference and its environment may be defined by means of *gates*.

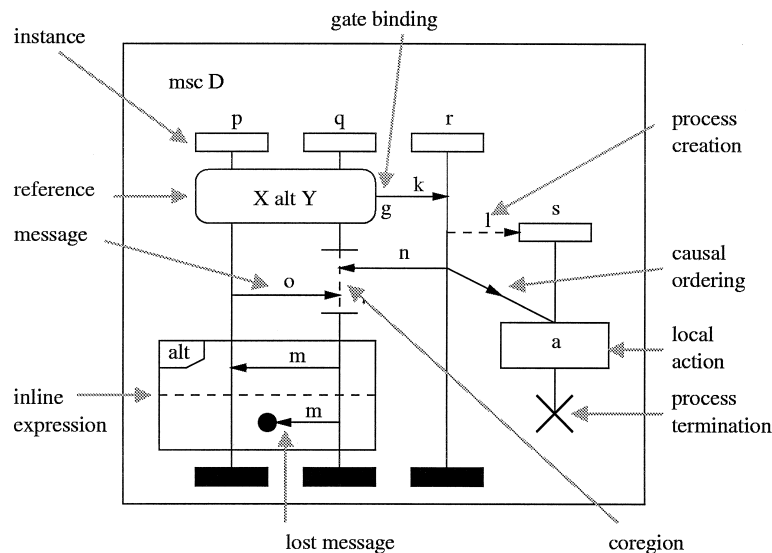

Fig. 1. Some MSC features.

A similar construct is the *inline expression*. Operators are again used to relate several parts of an MSC. This is mainly intended to be used for small variations of a scenario.

In MSC reference expressions and inline expressions the following operators are at the disposal of the user: alternative ('alt'), sequential ('seq') and parallel composition ('par'), a family of loop operators ('loop'), and operators for describing optional behaviour ('opt') and exceptions ('exc').

Finally, we have *substructure references*, which stem from MSC'93. These allow one to aggregate the behaviour of a number of instances into one.

The graphical syntax of some of the above-mentioned constructs is illustrated in the MSC depicted in Fig. 1.

3. Transformation

The first step in giving semantics to a language is the definition of a transformation from that language to a mathematical domain. In case of the operational semantics for MSC, we choose to transform MSCs into expressions over a signature that is introduced step by step in the remainder of this section. A signature describes a collection of constants and operator names, over which expressions may be formed. In this article, the transformation is defined on the graphical representation of MSCs. Since the definition of the graphical syntax of MSC'96 is not precise, in a more formal treatment the starting point for the transformation would be the textual syntax of MSC'96.

With the appearance of MSC'96, there are two main description styles for MSCs in the textual representation: the *instance-oriented* and the *event-oriented* description. With an instance-oriented description, an MSC is given by describing all its instances, whereas with the event-oriented description, an MSC is given by listing all building blocks (events, coregions, MSC references and inline expressions) contained in such a way that per instance the order of the building blocks respects the order of these building blocks in the graphical syntax from top to bottom.

The transformation presented here is defined on the event-oriented textual syntax of MSC'96. This is

sufficient, as every MSC can be expressed with this description style. Of course, a formal definition of the transformation from an arbitrary textual description of an MSC to an event-oriented description should be provided. The choice for the event-oriented textual syntax is based on the observation that every MSC can be composed of building blocks by means of *vertical composition* only. In principle there are several ways to decompose an MSC into building blocks. It should be the case that different vertical decompositions of the same MSC result in 'equivalent' expressions.

To illustrate the decomposition of an MSC into its building blocks consider the MSC depicted in Fig. 2. The building blocks of this MSC are the message output and input events. In Fig. 3 the vertical decomposition of this MSC is indicated by means of dashed lines separating the building blocks. Note that we first had to rearrange the drawing. In the event-oriented representation of such an MSC the building blocks are already listed in a suitable order. Also for readability we duplicated the message identifiers in such a way that one can easily associate a message identifier with an event. For the moment, ignore the annotations at the borders of the MSC in Fig. 3. They will be explained later.

The transformation is such, that events are mapped to constants and that for each of the composition mechanisms offered by MSC'96, an operator is introduced into the signature to act as the semantical equivalent of the composition mechanism.

We describe the transformation for each of the classes used in the previous section to introduce the language MSC'96. It is impossible to give a treatment of the complete language MSC'96 in this article and, therefore, we focus on the compositionality

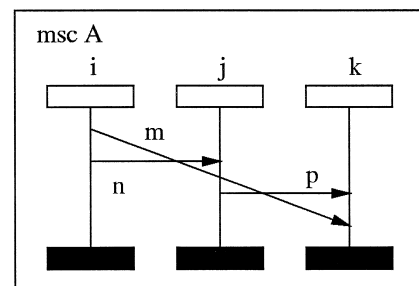

Fig. 2. Example MSC.

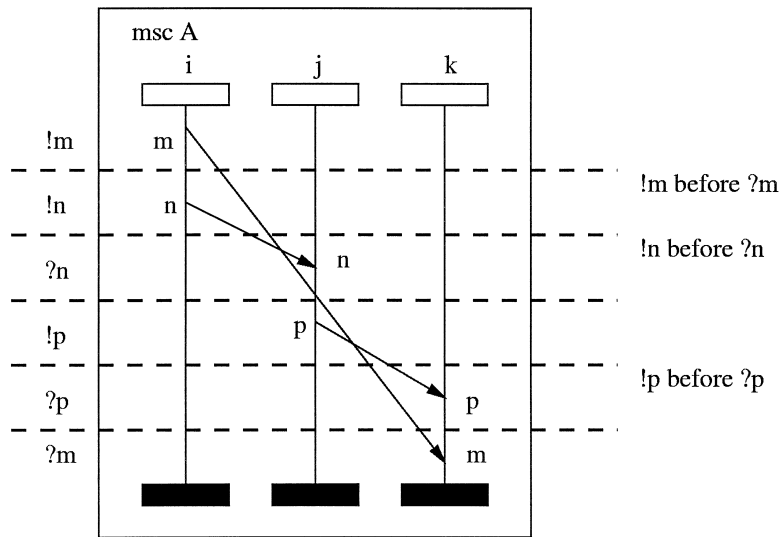

Fig. 3. Example MSC with separated events.

of the transformation and the explanation of the basic ideas. Examples are added to increase the understanding. The MSC from Fig. 2 is used as a running example to explain the transformation described in this section.

3.1. Events

Any of the previously discussed events is represented by a constant in the signature. The set of all these constants is denoted by A and the constants are called *atomic actions*. Such an atomic action can have a number of arguments which give additional information such as the name of the event, the name of the instance it is attached to, etc.

For a local action with action name a which is attached to instance i we use the atomic action $action(i,a)$. The sending of a message m from instance i to instance j is described by $out(i,j,m)$ and the reception of this message by $in(i,j,m)$.

In the previously introduced example (see Fig. 2) all building blocks are events. On the left side of the MSC in Fig. 3 we indicate how these are represented in the semantics. If the message identifier is unique, we often write $!m$ and $?m$ instead of $out(i,j,m)$ and $in(i,j,m)$. Similarly, $action(i,a)$ is represented by a . The reason for these shorthands is the readability of the expressions to follow.

3.2. Ordering

As described in Section 2.2, there are four ordering mechanisms in the MSC'96 language. The first of these, the ordering of events by placing them on an instance, is captured semantically by the *weak sequential composition* operator (\circ). This operator corresponds to the vertical composition of building blocks. If two building blocks are composed vertically, the instances they have in common are linked in such a way that the events from such a common instance in the first building block precede the events on that instance in the second building block. A simple example of vertical composition is given in Fig. 4. The vertical composition of the MSCs A and B is denoted by $A \circ B$ and it is 'equivalent' with MSC AB . The vertical composition does not mean that all events from MSC A must be executed before events of MSC B are executed. For example, the sending of message n can occur before the reception of message m .

The second way of ordering events is the coregion construct. In fact, this construct is introduced to describe the absence of ordering. This means that the events in a coregion can be executed in any order. Semantically, this absence of ordering is denoted by means of the *parallel composition* operator (\parallel). This operator corresponds to the *horizontal composition*

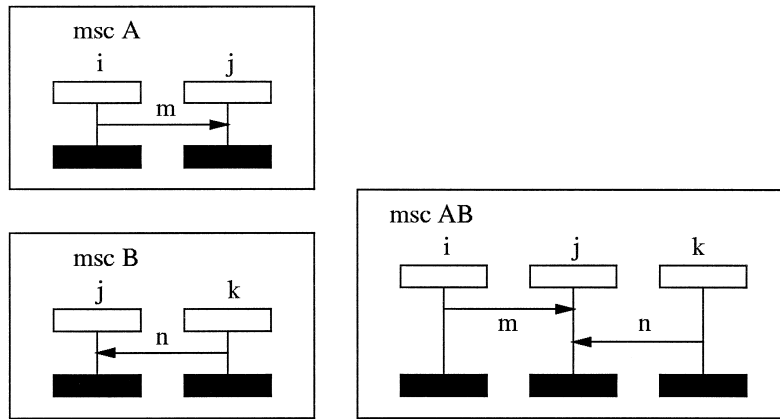

Fig. 4. Vertical composition.

of building blocks. If the building blocks that are composed have instances in common the behaviours of these are interleaved. A simple example to illustrate the representation of coregions is the following. Suppose that we have a coregion with events e_1, e_2, e_3 and e_4 and suppose that these events are semantically represented by the atomic actions a_1, a_2, a_3 and a_4 . Then, semantically this coregion is represented by the expression $a_1 \parallel (a_2 \parallel (a_3 \parallel a_4))$. Since the parallel composition operator is associative and commutative, the parentheses can be omitted.

In order to describe the causal orderings and the message orderings, we need more machinery. For the message orderings, we need to express that the message output precedes the message input. This can be achieved by using a state operator, as was done in Ref. [22]. However, this approach does not generalise easily for the causal orderings. Therefore, we need a more general means to describe ordering. This is achieved by attributing the operators for the composition of building blocks with a set of ordering requirements. Such an ordering requirement is represented as $e_1 \mapsto e_2$ and should be read as: event e_1 must precede event e_2 .

The attributed composition operators are called the *generalised weak sequential composition operator* (\circ^S) and the *generalised parallel composition operator* (\parallel^S). Usually we refer to these as vertical and horizontal composition. The weak sequential composition operator and the parallel composition operator are special cases of \circ^S and \parallel^S where

$S = \emptyset$. Still, we prefer to denote \circ^{\emptyset} by \circ and \parallel^{\emptyset} by \parallel . Often, we omit the curly brackets from the set S and simply list the ordering requirements separated by comma's. These attributes can be used to describe causal orderings, as well as message orderings. For a message m the message ordering is represented by the pair $!m \mapsto ?m$.

For the running example, this means that it is described by the vertical composition of the building blocks and that at certain points additional ordering requirements are attributed to the vertical composition operator. Note that the orderings imposed by the instances are taken care of by the vertical composition operator on its own. After applying our transformation to MSC A from Fig. 3 the following expression results:

$$!m \circ^{!m \mapsto ?m} (!n \circ^{!n \mapsto ?n} (?n \circ (!p \circ^{!p \mapsto ?p} (?p \circ ?m))))$$

This expression is obtained by considering the dashed lines in Fig. 3 one by one from top to bottom. With each dashed line an occurrence of \circ^S is associated. If this line is crossed by a message arrow this results in an ordering requirement. Of course every such arrow should be considered only once.

3.3. Design

The combination of building blocks is in MSC expressed explicitly by means of operators (inline

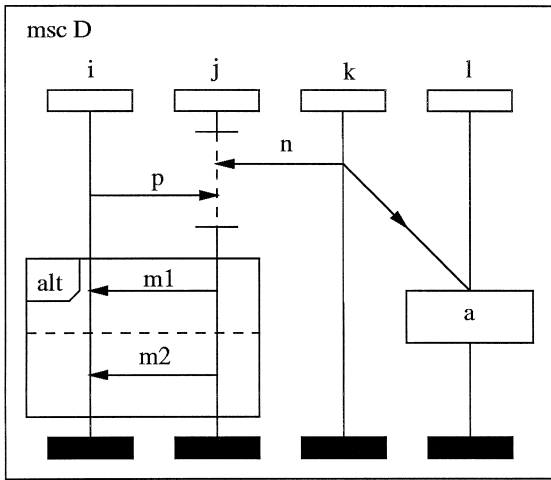

Fig. 5. Example MSC *D*.

expressions, MSC reference expressions) or by means of graphical constructions that can be reduced to operators (HMSCs). From a semantical point of view the three ways to combine building blocks can be

described in one framework. In this article, we do not consider substructure references. For a thorough treatment of those we refer to [23,15]. Also gates and substitutions are not treated in this article. Gates are difficult but not troublesome and substitution should be trivial.

Semantically, all we need for describing the composition mechanisms are the following operators: delayed choice ($\bar{\sqcap}$) for ‘alt’, vertical composition (\circ^S) for ‘seq’, horizontal composition (\parallel^S) for ‘par’, several repetition operators to capture the ‘loop’ construct and recursion (for HMSC).

The delayed choice [2] is an operator for describing alternative scenarios in such a way that a choice between the alternatives is postponed for as long as possible. For example, if both alternatives can execute an event *a*, then after the execution of *a* there are still two alternatives. If, on the other hand, only one of the alternatives can execute event *a*, then after the execution of *a* only one alternative remains. This is the alternative that executed *a*. The vertical and horizontal composition operators have been in-

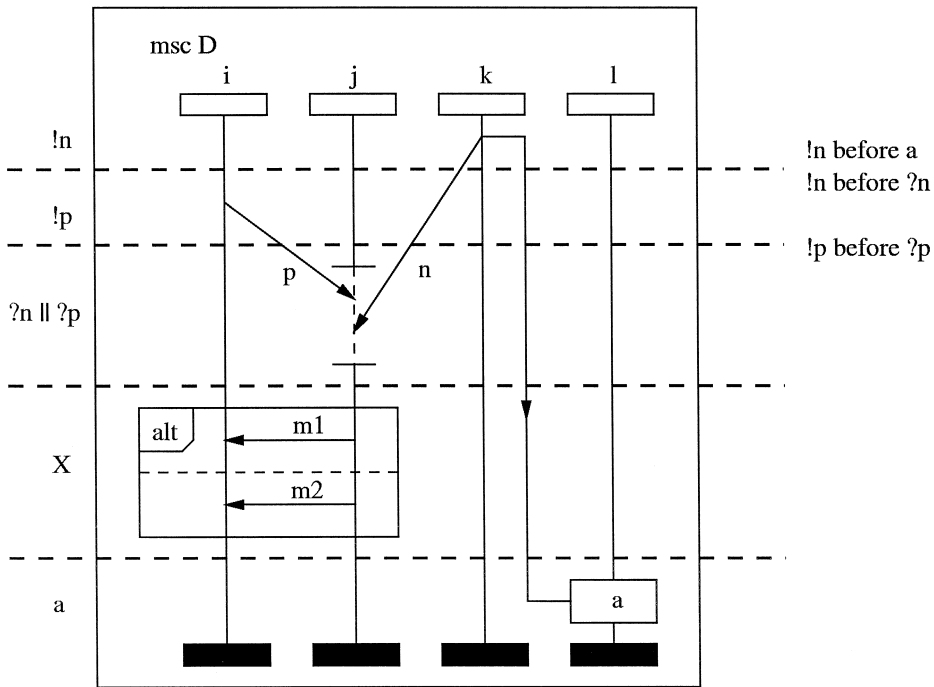

Fig. 6. Vertical decomposition of MSC *D*.

troduced already in the previous section. The constructs *optional* and *exception* (newly introduced in MSC'96) are easily captured as special cases of delayed choice and are therefore not considered in this article. The loop operators are based on bounded and unbounded versions of the iteration operator defined in Ref. [5]. Also these are not considered in this article. For an initial treatment of recursion we refer to [24].

We once more explain the transformation by means of an example. We start from the MSC given in Fig. 5. This example shows how to deal with complex building blocks such as coregions and inline expressions.

The first step is to make an alternative drawing in which a vertical composition of the MSC into building blocks can easily be indicated. A possible result of this transformation is shown in Fig. 6.

The next step is to associate an expression with the MSC as follows. First, with each of the building blocks an expression is associated. For the events this expression is merely a single atomic action and for the coregion we obtain $?n \parallel ?o$ as explained in the previous section. For the inline expression first an expression is given for each of the operands (two in this case): $!m1 \circ !m1 \rightarrow ?m1 ?m1$ and $!m2 \circ !m2 \rightarrow ?m2 ?m2$. Then these are combined by means of the operator indicated in the inline expression. In this case, this is the alternative composition operator 'alt' which is semantically represented by means of delayed choice \mp . The result is the expression

$$(!m1 \circ !m1 \rightarrow ?m1 ?m1) \mp (!m2 \circ !m2 \rightarrow ?m2 ?m2).$$

The expressions associated with the building blocks are also displayed in Fig. 6 on the left of the MSC. The semantics of the inline expression is in the figure abbreviated by X , which represents the above expression.

Then, the ordering requirements between the building blocks must be determined and taken into account. These are depicted in the figure on the right of the MSC. Note that in this step both the message orderings and the causal orderings are treated similarly. Finally, the expression representing the MSC is obtained as described before:

$$!n \circ !n \rightarrow a, !n \rightarrow ?n (!p \circ !p \rightarrow ?p ((?n \parallel ?p) \circ (X \circ a))).$$

4. Operational semantics

4.1. What is an operational semantics?

In this section, we introduce some terminology with respect to the mathematical framework that is used to define an operational semantics. Both terminology and notation are taken from [3]. The goal of an operational semantics is, given an expression denoting a process in a certain state, to describe all possible activities that can be performed by the process in that state and to describe the state of the process after such an activity. In the previous section we gave a transformation of an MSC into an expression. This expression represents the initial state of the MSC. The activities that are considered for the operational semantics of MSC'96 are the execution of an event and the termination of the MSC. Also the states resulting after such activities are described by means of expressions. If from a state s an event a can be performed and the resulting state is represented by the expression s' , then this is usually denoted by the ternary relation $s \xrightarrow{a} s'$. If in a given state s the process is capable of terminating immediately and successfully, this is indicated by means of $s \downarrow$.

The predicate $- \downarrow \subseteq P$ is called the *termination predicate* as it indicates that a process has the possibility to terminate immediately and successfully. The set P denotes all expressions that can be built from the constants and operators in the signature. If we assume that all events are represented by atomic actions from the set A , the ternary relation $- \xrightarrow{a} - \subseteq P \times A \times P$ is called the *transition relation*. This predicate and these relations are defined by means of deduction rules (operational rules). A deduction rule is of the form $\frac{H}{C}$ where H is a set of premises and C is the conclusion. Each individual premise and the conclusion are of the form $s \xrightarrow{a} s'$ or $s \downarrow$ for arbitrary $s, s' \in P$ and $a \in A$. Such a deduction rule should be interpreted as follows: If all premises are true, the conclusion, by definition, also holds. A special kind of deduction rule appears if the set of premises is empty ($H = \emptyset$). Such a deduction rule is also called a deduction axiom and usually simply denoted by the conclusion C . An example of a deduction axiom is deduction axiom (At 1):

$$a \xrightarrow{a} \varepsilon.$$

This deduction axiom expresses that a process that is in a state represented by the atomic action a can perform event a and thereby evolves into a state represented by the expression ε . This expression ε indicates a state in which no events can be performed but in which it is possible to terminate successfully and immediately. This is expressed by the deduction axiom (E 1):

$\varepsilon \downarrow$.

These are the only rules for expressions $a \in A$ and ε . The expression ε is used to denote an MSC without events.

Clearly the process a cannot terminate and the process ε cannot perform events. Note that these *negative* results are not explicitly defined. The following convention applies: If it is impossible to derive $s \downarrow$, then by definition $\text{not } s \downarrow$, which is denoted by $s \not\downarrow$. Similarly, if it is impossible to derive $s \xrightarrow{a} s'$, then by definition $\text{not } s \xrightarrow{a} s'$. This is usually denoted as $s \not\xrightarrow{a} s'$. Such negative results can also be used in the set of premises, and then these are called *negative premises*. If we want to express that a process represented by the expression s can perform a transition labelled with a and we are not interested in the resulting state, this is denoted by $s \xrightarrow{a}$. Formally, it means that there exists a state s' such that $s \xrightarrow{a} s'$. Then $s \xrightarrow{a}$ should be read as there does not exist a state s' such that $s \xrightarrow{a} s'$, or for all states s' we have $s \not\xrightarrow{a} s'$. These abbreviations extend to the relation $- \cdots \xrightarrow{-} -$ to be introduced in Section 4.4.

4.2. Delayed choice

The operational semantics associated with delayed choice by means of the deduction rules presented in Table 1, eminently illustrates the purposes of this operator. The deduction rules for \xrightarrow{a} clearly express that $x \bar{\mp} y$ can perform an a -transition thereby resolving the choice if exactly one of its operands can, and in the case that both operands can perform an a -transition the choice is not yet resolved.

The deduction rules from Table 1 are taken from [2] where the delayed choice operator was introduced in the setting of bisimulation semantics as a means for composing MSCs. The deduction rules (DC 1) and (DC 2) express that the alternative composition

Table 1
Deduction rules for delayed choice.

$\frac{x \downarrow}{x \bar{\mp} y \downarrow}$ (DC 1)	$\frac{y \downarrow}{x \bar{\mp} y \downarrow}$ (DC 2)	
$\frac{x \xrightarrow{a} x', y \not\xrightarrow{a}}{x \bar{\mp} y \xrightarrow{a} x'}$ (DC 3)	$\frac{x \not\xrightarrow{a}, y \xrightarrow{a} y'}{x \bar{\mp} y \xrightarrow{a} y'}$ (DC 4)	$\frac{x \xrightarrow{a} x', y \xrightarrow{a} y'}{x \bar{\mp} y \xrightarrow{a} x' \bar{\mp} y'}$ (DC 5)

of two processes has the option to terminate if and only if at least one of the alternatives has this option. Thus, the process $a \bar{\mp} \varepsilon$ has an option to terminate, as the second alternative has this option. On the contrary the process $a \bar{\mp} b$ does not have an option to terminate, as none of its alternatives can terminate. Please note that if we speak of termination we mean immediate termination, not termination after the execution of one or more events. The deduction rules (DC 3) and (DC 4) express that, in the situation that exactly one of the alternatives can execute an event a , the alternative composition can execute this event as well, and that the execution of this event resolves the choice. Finally, deduction rule (DC 5) deals with the situation that both alternatives can execute an event a . It states that, in that case, the alternative composition can execute a and, moreover, that there remain two alternatives.

With the signature and deduction rules introduced so far it is hard to give interesting examples of how such an operational semantics can be exploited. But in order to already illustrate the machinery we give examples anyway.

As explained before, the delayed choice only resolves a choice if it has to. For example, if we consider the process $a \bar{\mp} b$, making a choice between the alternatives cannot be avoided. Operationally, this is seen as follows: By the deduction axiom (At 1) we obtain $a \xrightarrow{a} \varepsilon$. Since it is impossible to derive $b \xrightarrow{a}$ we obtain $b \not\xrightarrow{a}$. Combining these with the deduction rule (DC 3) we obtain $a \bar{\mp} b \xrightarrow{a} \varepsilon$ and the choice is resolved by the execution of a . In contrast, for the process represented by $a \bar{\mp} a$, we first obtain $a \xrightarrow{a} \varepsilon$, by deduction axiom (At 1), and therefore we cannot obtain $a \not\xrightarrow{a}$. Thus the deduction rule (DC 3) cannot be used this time. Instead the premises of

deduction rule (DC 5) hold in this case. Thus we can conclude $a \nabla a \xrightarrow{a} \varepsilon \nabla \varepsilon$. It is impossible to tell which a of the two alternatives was actually executed.

4.3. Generalised parallel composition

The generalised parallel composition operator is defined by the deduction rules in Table 2. It is labelled by a set S of pairs of atomic actions. This set specifies a number of ordering requirements on the execution of atomic actions. Before we explain the use of this set in more detail, we first explain the horizontal composition operator without considering this set. This turns out to be a special case, i.e., $S = \emptyset$. Instead of \parallel^\emptyset we often write \parallel . This is in line with notation used in the process algebra ACP [6,4,3,29].

The horizontal composition of two processes is the interleaved execution of the events of the processes while maintaining the ordering of events as specified by the processes in isolation. The horizontal composition operator used in the setting of MSC, is a delayed version of the interleaving operators normally used. If both the left-hand and right-hand side of the horizontal composition can perform the same event, it is not visible which of the two is actually executed. In other words a delayed choice is made between the two occurrences. In this aspect, the horizontal composition operator used for the semantics of MSC differs from the interleaving operators of ACP-style process algebras. Also the free merge operator (and weak sequencing operator) used in Ref. [24] does not make a delayed choice between alternatives.

Table 2
Deduction rules for generalised parallel composition.

$S' = S \setminus \{e_1 \mapsto e_2 \in S \mid e_1 = a\}$ and $\pi_2(S) = \{e_2 \mid \exists_{e_1} e_1 \mapsto e_2 \in S\}$	
$\frac{x \downarrow, y \downarrow}{x \parallel^S y \downarrow}$ (HC 1)	$\frac{x \xrightarrow{a} x', y \xrightarrow{a}, a \notin \pi_2(S)}{x \parallel^S y \xrightarrow{a} x' \parallel^S y'}$ (HC 2)
$\frac{x \xrightarrow{a} x', y \xrightarrow{a} y', a \notin \pi_2(S)}{x \parallel^S y \xrightarrow{a} x' \parallel^S y' \nabla x \parallel^S y'}$ (HC 3)	$\frac{x \xrightarrow{a}, y \xrightarrow{a} y', a \in \pi_2(S)}{x \parallel^S y \xrightarrow{a} x \parallel^S y'}$ (HC 4)

A simple example is the process $a \parallel b$. This process is capable of performing an event a and thereby it evolves into the process $\varepsilon \parallel b$. But it is also possible for this process to perform b and then the process $a \parallel \varepsilon$ remains. An example illustrating the delayed nature of the horizontal composition operator is the process represented by $a \parallel a$. It can perform the following sequence of transitions:

$$a \parallel a \xrightarrow{a} \varepsilon \parallel a \nabla a \parallel \varepsilon \xrightarrow{a} \varepsilon \parallel \varepsilon \nabla \varepsilon \parallel \varepsilon \downarrow.$$

Next, the way the set S is used is explained. The set S contains pairs of events $e_1 \mapsto e_2$. Such a pair describes a requirement on the order in which events from the operands may be executed. In this particular case, the pair should be read as: event e_2 can only be executed after event e_1 has been executed. This is precisely what is expressed in the deduction rules. Also observe that the set S is updated after the execution of every event. This update is explained later.

Consider the process $?m \parallel^{!m \mapsto ?m} !m$. If we do not consider the requirement $!m \mapsto ?m$, it would be possible to execute the events $?m$ and $!m$ in any order. However, the presence of the requirement blocks the execution of $?m$ as long as $!m$ has not been executed. Thus, the only possible sequence of transitions is:

$$?m \parallel^{!m \mapsto ?m} !m \xrightarrow{!m} ?m \parallel^{\varepsilon \mapsto ?m} \varepsilon \parallel^{\varepsilon \downarrow} \varepsilon \downarrow.$$

Next, we explain the deduction rules from Table 2 in more detail. Rule (HC 1) expresses that $x \parallel^S y$ has the possibility to terminate if both x and y have. Rules (HC 2) up to (HC 4) define which transitions the expression $x \parallel^S y$ is allowed to make. These rules have the premise $a \notin \pi_2(S)$. This means that the event a is allowed to occur. Namely, set S contains pairs of events for which an ordering is fixed. If, e.g., $e_1 \mapsto e_2$ is in S , this means that e_1 should occur before e_2 . After execution of e_1 the entry $e_1 \mapsto e_2$ is removed from S . Therefore, only events are blocked which occur at the right-hand side of an entry $e_1 \mapsto e_2$ in S . These right-hand sides are selected by the operation $\pi_2(S)$. This also explains why the set S in the conclusions of the rules is transformed into S' . Namely, if an a is executed, all requirements $a \mapsto e_2$ are trivially fulfilled and may thus be removed from the set S .

Knowing this, we can make a distinction between three cases. First, x can execute an a and y cannot ((HC 2)). In this case, $x \parallel^s y$ may perform this a and evolve into $x' \parallel^s y$. The case that x cannot execute an a and y can is symmetrical ((HC 4)). Finally, if both x and y can execute an a ((HC 3)), we need a delayed choice to express that execution of this a does not enforce a choice between x and y . The executed a may be either due to x or due to y .

4.4. Generalised weak sequential composition

In this section, we introduce the generalised weak sequential composition operator \circ^s . It can be thought of as the vertical composition of building blocks. The operator \circ , i.e. \circ^\emptyset , is based on the weak sequential composition operator of [27] and the interworking sequencing operator of [25]. It has a behaviour that is similar to the behaviour of the horizontal composition operator, but additionally, it maintains the ordering of events from instances that the building blocks have in common.

In MSC every event is associated with an instance on which it is defined. In the operational semantics this is incorporated by assuming a mapping $\ell: A \rightarrow I$, where I represents the set of all instance names, which associates with every event $a \in A$ the name of the instance it is defined on. This mapping is easily defined on the atomic actions from the set A , as these represent the events with the instance to which the event is attached as one of the parameters. For example, $\ell(out(i,j,m)) = i$, $\ell(in(i,j,m)) = j$ and $\ell(a) = i$. The mapping ℓ is used extensively in the operational description of vertical composition.

Besides the transition relation already present in the operational semantics we now also introduce a relation $-\cdots \xrightarrow{-} - \subseteq P \times A \times P$. This relation is called the *permission relation*. If $s \cdots \xrightarrow{a} s'$ this means that in a situation where s is vertically composed with t ($s \circ t$) and t can perform event a ($t \xrightarrow{a}$), s allows the execution of a by t ($s \circ t \xrightarrow{a}$). If on the other hand $s \cdots \not\xrightarrow{a}$ this means that in the same situation the vertical composition of s and t cannot perform event a from t .

However, there is a complication with respect to alternatives. Suppose that we have an MSC that describes two alternatives: the first is the execution of local action a on instance i and the second

alternative is the execution of local action b on instance j . Suppose furthermore that we wish to compose this MSC vertically with an MSC which can only execute local action c from instance i . The expression representing this vertical composition is given by

$$(action(i,a) \mp action(j,b)) \circ action(i,c).$$

Note that we did not abbreviate the atomic actions as we did in the previous sections. The reason is that the instance names are relevant for determining the permissions. Let us try to find out which transitions can be performed in this case. As before, it is possible to perform the local action a or the local action b :

$$(action(i,a) \mp action(j,b)) \circ action(i,c) \xrightarrow{action(i,a)} \varepsilon \circ action(i,c),$$

$$(action(i,a) \mp action(j,b)) \circ action(i,c) \xrightarrow{action(j,b)} \varepsilon \circ action(i,c).$$

After this transition, in both cases the choice has been made and clearly the next transition that can be performed is the execution of local action c . However, there is also the possibility that local action c appears even before the choice has been made. But then we know that local action a cannot be executed, because it should precede local action c . Therefore, the state after the execution of local action c , should not have the possibility to execute local action a anymore:

$$(action(i,a) \mp action(j,b)) \circ action(i,c) \xrightarrow{action(i,c)} action(j,b) \circ \varepsilon.$$

Suppose that we want to determine if an action a is allowed to precede a process x , i.e., we want to determine $x \cdots \xrightarrow{a}$. Then we use the deduction rules from Table 3 which are defined on the structure of the expressions. The empty process can be preceded by event a ; there is no reason not to allow a to be executed. This is expressed by deduction axiom (E 2). Similarly, an event b can be preceded by event a if and only if these events are defined on different instances ($\ell(a) \neq \ell(b)$), see deduction rule (At 2). The deduction rules (DC 6), (DC 7) and (DC 8) express that an event a is allowed to precede a process consisting of two alternatives if and only if

Table 3
Deduction rules for the permission relation.

$$\varepsilon \cdots \xrightarrow{a} \varepsilon \text{ (E 2)} \quad \frac{\mathcal{L}(a) \neq \mathcal{L}(b)}{b \cdots \xrightarrow{a} b} \text{ (At 2)} \quad \frac{x \cdots \xrightarrow{a} x', y \cdots \xrightarrow{a} y'}{x \mp y \cdots \xrightarrow{a} x'} \text{ (DC 6)}$$

$$\frac{x \cdots \xrightarrow{a} x', y \cdots \xrightarrow{a} y'}{x \mp y \cdots \xrightarrow{a} y'} \text{ (DC 7)} \quad \frac{x \cdots \xrightarrow{a} x', y \cdots \xrightarrow{a} y'}{x \mp y \cdots \xrightarrow{a} x' \mp y'} \text{ (DC 8)}$$

$$\frac{x \cdots \xrightarrow{a} x', y \cdots \xrightarrow{a} y'}{x \parallel^S y \cdots \xrightarrow{a} x' \parallel^S y'} \text{ (HC 5)} \quad \frac{x \cdots \xrightarrow{a} x', y \cdots \xrightarrow{a} y'}{x \circ^S y \cdots \xrightarrow{a} x' \circ^S y'} \text{ (VC 1)}$$

at least one of the alternatives allows a to precede. Please note that the operational rules also deal with the resolution of choices. For both the horizontal and the vertical composition operator the following holds. Event a can precede the composed process if and only if it can precede both operands ((HC 5) and (VC 1)).

The operational rules for vertical composition in Table 4 are similar to the operational rules for horizontal composition. The main difference is that an event from the right operand can only be executed if the left operand allows the execution of that event. Also note, that in case the left operand allows the execution of an event a from the right operand, it is possible that alternatives disappear from the left operand.

Deduction rule (VC 2) expresses that the vertical composition of two processes can terminate if each

Table 4
Deduction rules for generalised weak sequential composition.

$$S' = S \setminus \{e_1 \mapsto e_2 \in S \mid e_1 = a\} \text{ and } \pi_2(S) = \{e_2 \mid \exists e_1 e_1 \mapsto e_2 \in S\}$$

$$\frac{x \downarrow, y \downarrow}{x \circ^S y \downarrow} \text{ (VC 2)} \quad \frac{x \xrightarrow{a} x', y \xrightarrow{a} y' \vee x \cdots \xrightarrow{a} x', a \notin \pi_2(S)}{x \circ^S y \xrightarrow{a} x' \circ^S y'} \text{ (VC 3)}$$

$$\frac{x \xrightarrow{a} x', x \cdots \xrightarrow{a} x'', y \xrightarrow{a} y', a \notin \pi_2(S)}{x \circ^S y \xrightarrow{a} x' \circ^S y' \mp x'' \circ^S y'} \text{ (VC 4)}$$

$$\frac{x \xrightarrow{a}, x \cdots \xrightarrow{a} x', y \xrightarrow{a} y', a \notin \pi_2(S)}{x \circ^S y \xrightarrow{a} x' \circ^S y'} \text{ (VC 5)}$$

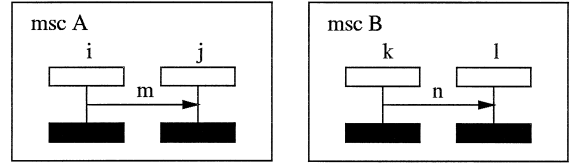

Fig. 7. Vertical composition with disjoint instances.

of them can terminate. The other deduction rules deal with the possible transitions of the vertical composition of two processes. As the vertical composition operator deals with the ordering requirements in the same way as the horizontal composition operator, this aspect of the deduction rules is not explained again.

In the case that x can perform event a ($x \xrightarrow{a}$) and either y cannot perform event a ($y \not\xrightarrow{a}$) or x does not allow the execution of event a by y ($x \cdots \not\xrightarrow{a}$), only the execution of event a by x can take place. This is expressed by deduction rule (VC 3).

In the case that x can perform event a ($x \xrightarrow{a}$), y can perform event a ($y \xrightarrow{a}$) and x permits the execution of a by y , a delayed choice of the individual occurrences of event a results. This is expressed by deduction rule (VC 4).

In the case that x cannot perform event a ($x \not\xrightarrow{a}$), y can perform event a ($y \xrightarrow{a}$) and x permits the execution of a by y ($x \cdots \xrightarrow{a}$), there is only the possibility that event a is executed due to y . This is expressed by deduction rule (VC 5).

The only case that is not discussed yet is the case that x cannot execute a and either x does not permit y to execute an event a or y cannot execute an event a . In this case, it is impossible to execute a at all. This is expressed implicitly by the fact that there is no deduction rule for which the premises hold in this situation.

The operational rules for the vertical composition operator are illustrated by means of some examples. First, consider the MSCs from Fig. 7. The MSCs A and B have no instances in common. Semantically, they are represented by the following expressions, denoted by A and B for easy reference:

$$A = out(i, j, m) \circ out(i, j, m) \mapsto in(i, j, m) in(i, j, m),$$

$$B = out(k, l, n) \circ out(k, l, n) \mapsto in(k, l, n) in(k, l, n).$$

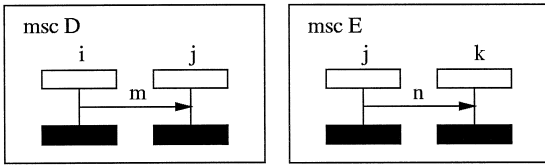

Fig. 8. Vertical composition with instances in common.

The vertical composition of MSC A and MSC B is then denoted by $A \circ B$. From the deduction rules we obtain that this process can perform the following transitions:

$$A \circ B \xrightarrow{out(i,j,m)} (\varepsilon \circ in(i,j,m)) \circ B,$$

$$A \circ B \xrightarrow{out(k,l,n)} A \circ (\varepsilon \circ in(k,l,n)).$$

The first possibility follows from the deduction rules as follows. First, $A \xrightarrow{out(i,j,m)} \varepsilon \circ in(i,j,m)$ and second $B \xrightarrow{out(i,j,m)}$.

The second possibility is obtained from $A \xrightarrow{out(k,l,n)}$ and $B \xrightarrow{out(k,l,n)} \varepsilon \circ in(k,l,n)$.

An example in which the MSCs to be composed vertically have instances in common is given in Fig. 8. The MSCs D and E are represented by

$$D = out(i,j,m) \circ out(i,j,m) \rightarrow in(i,j,m) in(i,j,m),$$

$$E = out(j,k,n) \circ out(j,k,n) \rightarrow in(j,k,n) in(j,k,n).$$

The vertical composition of the MSCs D and E is denoted by $D \circ E$. In this case, the only initial transition is $D \circ E \xrightarrow{out(i,j,m)} (\varepsilon \circ in(i,j,m)) \circ E$. The execution of $in(i,j,m)$ is blocked by the requirement that $out(i,j,m)$ must be executed first, the execution of $out(j,k,n)$ is blocked by the requirement that all events on the same instance, i.e., instance j from D , must be executed first (and that is not the case) and the execution of $in(j,k,n)$ is blocked by the requirement that $out(j,k,n)$ must be executed first. Note that there is actually only one sequence of transitions in this example:

$$D \circ E \xrightarrow{out(i,j,m)} (\varepsilon \circ in(i,j,m)) \circ E$$

$$\xrightarrow{in(i,j,m)} (\varepsilon \circ \varepsilon) \circ E$$

$$\xrightarrow{out(j,k,n)} (\varepsilon \circ \varepsilon) \circ (\varepsilon \circ in(j,k,n))$$

$$\xrightarrow{in(j,k,n)} (\varepsilon \circ \varepsilon) \circ (\varepsilon \circ \varepsilon) \downarrow.$$

4.5. Use of operational semantics

By means of the operational semantics, a transition graph can be associated with every expression. Such a transition graph consists of nodes and arrows between them. A node is labelled by an expression over the signature. Suppose that we are given a node s and suppose that we can derive $s \xrightarrow{a} s'$ for certain a and s' . Then the transition graph also contains a node labelled s' and an arrow labelled with a from node s to node s' . In this way, the transition graph can be built. The transition graph for an expression s has exactly one initial node. This is the node labelled with s . This node is indicated by an incoming unconnected and unlabelled arrow. If for a node s we can derive $s \downarrow$ then this is indicated in the transition graph by labelling that node by an outgoing unconnected and unlabelled arrow.

For example, the transition graph associated with $A \circ B$, i.e. the vertical composition of the MSCs A and B from Fig. 7 is given in Fig. 9. Usually, we omit the labels of the nodes.

The operational semantics presented can be used to define a notion of equivalence on processes. Examples thereof are *trace equivalence*, *bisimulation equivalence* and *graph isomorphism*. The intended equivalence for MSC'96 is bisimulation equivalence. For a definition of this equivalence we refer to [26]. In the case of MSC'96, we only have deterministic processes, which means that it is not possible for a process to perform an a -transition to two states

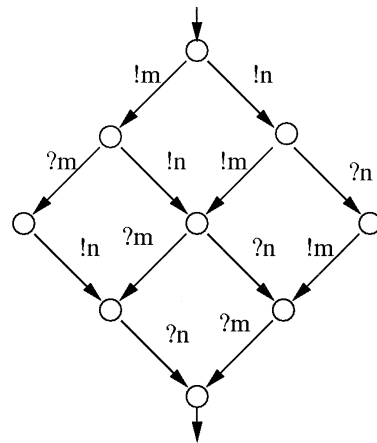

Fig. 9. Transition graph.

represented by different expressions. In this case the notions of trace equivalence and bisimulation equivalence coincide [8].

The reason to use bisimulation equivalence anyway is that we anticipate at an extension of the set of operators with an operator for non-deterministic choice [4]. In the presence of non-deterministic choice, there is a difference between trace semantics and bisimulation semantics. The definition of the operational semantics for MSC'96 is such that it can easily be extended with non-deterministic choice.

Another interesting topic related to operational semantics is the development of a simulator. With a simulator sequences of events can be generated at random or user-driven. The basic functionality of a simulator resembles the definition of an operational semantics. For Basic Message Sequence Charts, i.e., Message Sequence Charts with only instances, messages and local actions, in Ref. [21] the process algebra semantics of MSC'93 is used to define a prototype simulator.

5. Summary and concluding remarks

We have explained the basics of the formal semantics of MSC'96 which are currently under development.

The semantics of an MSC is derived in several steps. First, an MSC in graphical representation is translated into a textual form. This transformation is not discussed. Next, the textual representation is translated into a process algebra expression. Finally a meaning is attached to such an expression.

A major design issue was compositionality. An MSC is thought of as being constructed from a number of building blocks, each of which may also be compound constructs. The semantics of a construction is defined as the composition of the semantics of its building blocks. At the lowest level there are only events, which have a trivial interpretation as atomic actions. The ordering of these events is taken care of by the operators for vertical and horizontal composition. Constructs for design in the large are interpreted as applications of several operators.

We obtained an operational semantics, which consists of a description of the (possible) behaviour of an MSC. We did not provide for any process algebraic

axioms as presented in Refs. [22,23]. We expect a complete axiomatisation to be infeasible. Nevertheless, an operational semantics as proposed here, serves several purposes. First, it unambiguously defines the meaning of an MSC by interpreting an MSC in the mathematical model of transition graphs. Next, it allows for a good comparison to alternative semantics definitions of MSC, such as approaches based on Petri nets [9], Büchi automata [17], process algebra [19,25], and partial orders [1]. Moreover, it enables a comparison to other languages for the description of distributed systems, such as SDL [12] and LOTOS [7], which are also provided with a formal semantics which can be interpreted easily in an operational way. Finally, an operational semantics is useful for the development of tools for simulation, validation and transformation of MSCs.

The semantics obtained is mostly an extension of the formal semantics of MSC'93 in Ref. [15]. A major difference is that the state operator, used for enforcing the message orderings, is replaced by the generalised weak sequential composition operator. The reason is that the latter allows for a uniform treatment of the message orderings and causal orderings and corresponds closely to the vertical composition of MSCs.

Acknowledgements

We would like to thank the members of the MSC development group for their initiating work. André Engels is acknowledged for the fruitful discussions on some technical matters.

References

- [1] R. Alur, G.J. Holzmann, D. Peled, An analyzer for Message Sequence Charts, *Software - Concepts and Tools* 17 (2) (1996) 70–77.
- [2] J.C.M. Baeten, S. Mauw, Delayed choice: an operator for joining Message Sequence Charts, in: D. Hogrefe, S. Leue (Eds.), *Formal Description Techniques VII, IFIP Transactions C, Proceedings 7th International Conference on Formal Description Techniques*, Chapman-Hall, 1994, pp. 340–354.
- [3] J.C.M. Baeten, C. Verhoef, Concrete process algebra, in: S. Abramsky, Dov M. Gabbay, T.S.E. Maibaum (Eds.), *Semantic Modelling, Handbook of Logic in Computer Science*, vol. 4, Oxford University Press, 1995, pp. 149–268.

- [4] J.C.M. Baeten, W.P. Weijland, *Process Algebra*, Cambridge Tracts in Theoretical Computer Science, vol. 18, Cambridge University Press, 1990.
- [5] J.A. Bergstra, I. Bethke, A. Ponse, Process algebra with iteration and nesting, *The Computer Journal* 37 (4) (1994) 243–258.
- [6] J.A. Bergstra, J.W. Klop, Process algebra for synchronous communication, *Information and Control* 60 (1/3) (1984) 109–137.
- [7] T. Bolognesi, E. Brinksma, Introduction to the ISO specification language LOTOS, *Computer Networks and ISDN Systems* 14 (1) (1988) 25–59.
- [8] J. Engelfriet, Determinacy \rightarrow (observation equivalence = trace equivalence), *Theoretical Computer Science* 36 (1) (1985) 21–25.
- [9] J. Grabowski, P. Graubmann, E. Rudolph, Towards a Petri net based semantics definition for Message Sequence Charts, in: O. Færgemand, A. Sarma (Eds.), *SDL'93 - Using Objects*, Proceedings of the Sixth SDL Forum, Darmstadt, 1993, Amsterdam, North-Holland, pp. 179–190.
- [10] Ø. Haugen, MSC structural concepts, Technical Report TD 9006, ITU-T Experts Meeting SG 10, Turin, 1994.
- [11] Ø. Haugen, Y. Lahav, MSC/SDL new features, *Tutorials of the Eighth SDL Forum*, 1997.
- [12] ITU-T, ITU-T Recommendation Z.100: Specification and Description Language (SDL), ITU-T, Geneva, 1992.
- [13] ITU-T, ITU-T Recommendation Z.100 Annex I: SDL Methodology Guidelines, ITU-T, Geneva, 1993.
- [14] ITU-T, ITU-T Recommendation Z.120: Message Sequence Chart (MSC), ITU-T, Geneva, September 1993.
- [15] ITU-T, ITU-T Recommendation Z.120 Annex B: Algebraic semantics of Message Sequence Charts, ITU-T, Geneva, April 1995.
- [16] ITU-T, ITU-T Recommendation Z.120: Message Sequence Chart (MSC96), ITU-T, Geneva, 1996.
- [17] P.B. Ladkin, S. Leue, Interpreting message flow graphs, *Formal Aspects of Computing* 7 (5) (1995) 473–509.
- [18] S. Loidl, E. Rudolph, U. Rinkel, MSC'96 and beyond - a critical look, in: A. Cavalli, A. Sarma (Eds.), *SDL'97: Time for Testing - SDL, MSC and Trends*, Proceedings of the Eighth SDL Forum, Evry, France, 1997, Elsevier Science Publishers, pp. 213–227.
- [19] J. de Man, Towards a formal semantics of Message Sequence Charts, in: O. Færgemand, A. Sarma (Eds.), *SDL'93: Using Objects*, Proceedings of the Sixth SDL Forum, Darmstadt, 1993, Amsterdam, North-Holland, pp. 157–165.
- [20] S. Mauw, The formalization of Message Sequence Charts, *Computer Networks and ISDN Systems* 28 (12) (1996) 1643–1657, Special issue on SDL and MSC, guest editor Ø. Haugen.
- [21] S. Mauw, E.A. van der Meulen, Generating tools for Message Sequence Charts, in: R. Bræk, A. Sarma (Eds.), *SDL'95 with MSC in CASE*, Proceedings of the Seventh SDL Forum, Oslo, 1995, Amsterdam, North-Holland, pp. 51–62.
- [22] S. Mauw, M.A. Reniers, An algebraic semantics of Basic Message Sequence Charts, *The Computer Journal* 37 (4) (1994) 269–277.
- [23] S. Mauw, M.A. Reniers, An algebraic semantics of Message Sequence Charts, Technical Report CSN 94/23, Eindhoven University of Technology, Department of Computing Science, Eindhoven, 1994.
- [24] S. Mauw, M.A. Reniers, High-Level Message Sequence Charts, in: A. Cavalli, A. Sarma (Eds.), *SDL'97: Time for Testing - SDL, MSC and Trends*, Proceedings of the Eighth SDL Forum, Evry, France, 1997, Elsevier Science Publishers, pp. 291–306.
- [25] S. Mauw, M. van Wijk, T. Winter, A formal semantics of synchronous Interworkings, in: O. Færgemand, A. Sarma (Eds.), *SDL'93 - Using Objects*, Proceedings of the Sixth SDL Forum, Darmstadt, 1993, Amsterdam, North-Holland, pp. 167–178.
- [26] D.M.R. Park, Concurrency and automata on infinite sequences, in: P. Deussen (Ed.), *Theoretical Computer Science, Lecture Notes in Computer Science*, vol. 104 Springer-Verlag, 1981, pp. 167–183; Proceedings of the Fifth GI-Conference, Karlsruhe, West Germany.
- [27] A. Rensink, H. Wehrheim, Weak sequential composition in process algebras, in: B. Jonsson, J. Parrow (Eds.), *CONCUR'94: Concurrency Theory, Lecture Notes in Computer Science*, vol. 836, Uppsala, 1994, Springer, pp. 226–241.
- [28] E. Rudolph, J. Grabowski, P. Graubmann, Tutorial on Message Sequence Charts (MSC'96), *Tutorials of the First joint International Conference on Formal Description Techniques for Distributed Systems and Communication Protocols, and Protocol Specification, Testing, and Verification (FORTE/PSTV'96)*, 1996.
- [29] J.L.M. Vrancken, The algebra of communicating processes with empty step, *Theoretical Computer Science* 177 (2) (1997) 287–328.

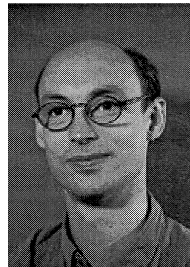

Sjouke Mauw is lecturer at the Eindhoven University of Technology, The Netherlands. His research focuses on formal specification and verification of concurrent systems. He designed the specification language PSF, which is based on process algebra and algebraic specifications. Being associate rapporteur for the International Telecommunication Union (ITU), he is responsible for the formalization of Message Sequence Charts. This is a graphical specification language recommended by the ITU. He received his M.Sc. in mathematics in 1985 and his Ph.D. in computer science in 1991, both from the University of Amsterdam.

Michel Reniers is scientific researcher at CWI, the Dutch National Research Institute for Mathematics and Computer Science. His research focuses on formal specification and verification of concurrent systems. From 1994 until now he has actively participated in the standardization effort of ITU-T for the graphical language MSC. He hopes to receive his Ph.D. in computer science in 1999, from the University of Eindhoven.