

Constitutive Hybrid Processes

P.J.L. Cuijpers, J.F. Broenink and P.J. Mosterman

June 1, 2004

1 Introduction

When modeling a physical system, it is common practice to describe the components that constitute the system, using so-called constitutive relations on the physical variables that play a role in the system. The intersection of all these relations then forms a model of the system as a whole. The behavior of physical systems is usually assumed to be continuous and, therefore, the constitutive relations are often stated as differential algebraic equations. When part of the continuous behavior occurs very fast, however, as is for example the case when studying impact phenomena, it may be convenient to describe this behavior as being discontinuous. The constitutive relations that are used to describe the system, should in that case not only contain algebraic differential equations (for the large time-scale behavior), but using also equations that describe the discontinuous behavior (for the behavior during impact).

In this report, we describe the constitutive relations of many more-or-less standard components in physical modeling, using the hybrid process algebra HyPA [4]. This algebra allows us to describe combinations of continuous and discontinuous behavior as one, hybrid, process (hence, the title of this report). As a vehicle for our thoughts, we use a graphical language named *bond graphs* [11] to formalize our physical models, before engaging in the construction of constitutive relations for them. Bond graphs generalize all domains of physics, such as electronics, hydraulics, and mechanics, in one framework. Recently, they have been extended with elements that are suitable for describing discontinuous behavior [10, 9, 1, 12]. This report, can therefore also be considered an attempt to give a formal semantics to hybrid bond graphs. Our expectation is, that after we have explained how to derive hybrid constitutive processes using hybrid bond graphs, it will also be easier to derive these processes directly, without using bond graphs as an intermediate step. Nevertheless, the construction of a bond graph sometimes gives additional insight in the workings of a system, and can facilitate analysis in many ways (see for example [8, 14, 3, 2]). In general, different model representations have strengths in different kinds of analysis.

In the next section, we give a short discussion on the modeling of physical systems through constitutive relations, using an example from mechanical engineering. Then, we briefly explain the traditional bond graph modeling method and discuss the need for abstraction from small time-scale behavior. In section 3 we briefly discuss the syntax and semantics of hybrid process algebra [4]. In section 4, we turn back to the bond graph modeling formalism, to see how the constitutive relations of the bond graph elements can be extended to include discontinuous behavior. In the last section, we give modeling examples that show how hybrid bond graph models can be made of several physical systems, and how these bond graph models can be turned into constitutive hybrid processes describing the systems algebraically.

2 Modeling physical systems

2.1 Constitutive equations

In dynamic systems theory, a common approach to build a model of a physical system, is by decomposing the system into separate components, and capturing the physical properties of those components in so-called constitutive relations on the physical variables that play a role in the system under study.

For example, in mechanics, traditionally five major variables play a role: energy E , momentum p , force F , displacement x and velocity v . All mechanical behavior, can be expressed in terms of interaction between these variables, and the way they change over time. A change in momentum corresponds to a force, leading to the constitutive differential equation $F = \dot{p}$, where \dot{p} denotes the time-derivative of p . A change in displacement corresponds to a velocity $v = \dot{x}$, and a change in energy (i.e. power) is the product of force and velocity $\dot{E} = F \cdot v$. These three relations play a role in every mechanical component, and are (implicitly or explicitly) part of the constitutive relations of every component.

Three major mechanical components can be distinguished: masses, springs and dampers. A mass gives rise to a constitutive relation between momentum p and velocity v . A spring gives a constitutive relation between displacement x and force F . A damper gives a constitutive relation between force F and velocity v . Often, these relations are non-linear, but in idealized models we represent masses, springs and dampers using linear algebraic equations, that depend on the factors m, k and b respectively:

$$\begin{aligned} \text{Mass} & : p = m \cdot v \\ \text{Spring} & : F = k \cdot x \\ \text{Damper} & : F = b \cdot v \end{aligned}$$

As an example of a non-linear relationship, one might consider a damping effects like friction, in which a constant normal force counteracts the direction of movement,

$$\text{Friction} : F = \text{sign}(v) \cdot F_N$$

and stiction, in which an initial additional force is necessary to get an object to move.

$$\text{Stiction} : F = \begin{cases} F_S & ; v = 0 \\ 0 & ; v \neq 0 \end{cases}$$

A connection of mechanical components leads to an exchange of energy between these components, in such a way that the momentum of the components is preserved, or the displacement of the components is preserved, depending on the connection. If we have conservation of momentum, the change in displacement of all components involved is equal. While if we have conservation of displacement, the change in momentum is equal. For n components, these types of connection are reflected in the following equations. The connection with conservation of momentum is described using

$$\begin{pmatrix} \dot{E}_1 + \dots + \dot{E}_n = 0 \\ \dot{p}_1 + \dots + \dot{p}_n = 0 \\ \dot{q}_1 = \dots = \dot{q}_n \end{pmatrix}.$$

These equations turn out to hold, if and only if

$$\begin{pmatrix} F_1 + \dots + F_n = 0 \\ v_1 = \dots = v_n \end{pmatrix}.$$

Observe, that the equation for conservation of energy is redundant. Dually, conservation of displacement is described using:

$$\begin{pmatrix} \dot{E}_1 + \dots + \dot{E}_n = 0 \\ \dot{q}_1 + \dots + \dot{q}_n = 0 \\ \dot{p}_1 = \dots = \dot{p}_n \end{pmatrix},$$

which is equivalent to stating

$$\begin{pmatrix} v_1 + \dots + v_n = 0 \\ F_1 = \dots = F_n \end{pmatrix}.$$

In figure 1, a mass-spring-damper system is depicted, as well as a set of constitutive equations that can be derived for it. All forces and directions are defined to be positive in the upward direction. This has to be taken into account when writing down the relations for conservation of momentum and displacement. Note, that the constitutive equations that are shown, give all

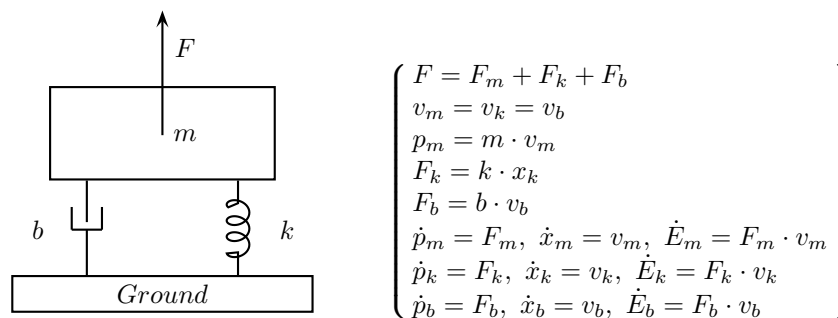

Figure 1: Constitutive equations for a mass-spring-damper system

relations between all five major variables. And, although we already left out the equations for conservation of energy, there is still quite some redundancy in this set of equations. In this report, we will mainly concern ourselves with the construction of a set of constitutive relations for hybrid systems, not with the elimination of redundant variables in the resulting model.

For other fields in physics, such as thermodynamics, electronics, and fluid dynamics, similar ways of deriving constitutive equations apply. Based on this observation, a unifying approach to dynamic systems modeling, called bond graphs, was developed by the late H.M. Paynter in the late fifties [11].

2.2 Bond graphs

The main observation behind bond graphs, is that the notions of force and velocity from mechanical systems, have analog notions in many other fields of physics, so that we can generalize these notions and the laws that apply to them. In bond graph theory, the generalization of force is called *effort* (denoted e) and the generalization of velocity is called *flow* (denoted f). For the *generalized momentum*, denoted p , we have the constitutive relation $\dot{p} = e$, and for the *generalized displacement*, denoted q , we have $\dot{q} = f$. In table 1 we have summarized the analogies between different fields in physics, and their bond graph generalizations. Energy E , is already a domain

independent term, but, although this variable is fundamental in the physics behind bond graphs, it does not play an important role in bond graph modeling, because of the redundancy that was already pointed out in the previous section. In continuous models, the energy is completely determined by the other four variables.

Table 1: Bond graph variable analogies

	effort e	flow f	generalized momentum p	generalized displacement q
trans. mech.:	force F	velocity v	momentum p	displacement x
rot. mech.:	torque τ	ang. vel. ω	ang. mom. b	angular Θ
electronics:	voltage u	current i	flux link. λ	charge q
hydraulics:	pressure P	volume-flow Q	press. mom. p_p	volume V

The fundamental idea behind a bond graph, is that it depicts the way in which energy is stored in a component, and the way in which components exchange energy. Energy can be stored in a component in the form of generalized momentum or generalized displacement. The multiplicative relation between a change in energy and a change in generalized momentum and generalized displacement, given in equation (1), is called the *power relation*.

$$\dot{E} = \dot{p} \cdot \dot{q} = e \cdot f. \quad (1)$$

Now, let us consider a set C of components, that are connected in an energy conserving way. This means that the total energy that is stored in the components does not change. We obtain the equation:

$$\sum_{c \in C} \dot{E}_c = \sum_{c \in C} e_c \cdot f_c = 0. \quad (2)$$

Furthermore, if the connection between components conserves generalized momentum, we obtain

$$\sum_{c \in C} \dot{p}_c = \sum_{c \in C} e_c = 0, \quad (3)$$

while, if it preserves generalized displacement, we have

$$\sum_{c \in C} \dot{q}_c = \sum_{c \in C} f_c = 0. \quad (4)$$

This gives us the basic constitutive equations for describing the energy in a component, and the way in which components may exchange energy. As we will see further on, conservation of generalized momentum is always associated with equal flows of the components, while conservation of general displacement is associated with equal efforts. This is in line with the connection of mechanical components mentioned in the previous section.

The components themselves, can be described by giving a relation between p , q , e and f . We distinguish the following types of components, based on certain properties of their constitutive relation. Note, that we use the same symbol (in small capital letters) for the function defining the constitutive relation, as for the representation of an element in a bond graph. Also, the functions may depend on other variables of the system than the ones that are explicitly mentioned, as long as the given constraints are met.

- A *resistance* (bond graph symbol R), is a component with a constitutive relation $e = R(f)$ such that the function R satisfies $x \cdot R(x) \geq 0$ for all x . Consequently, $\dot{E} = e \cdot f \geq 0$, which models that a resistance dissipates energy from the rest of the system.

- An *inductance* (bond graph symbol I), is a component with a constitutive relation $f = I(p)$. This models a component that stores energy in the form of generalized momentum. For intrinsic stability of the component, it is usually assumed that the function I satisfies $\frac{\partial I(p)}{\partial p} > 0$ (see [2]).
- A *capacitance* (bond graph symbol C), is a component with a constitutive relation $e = C(q)$. This models a component that stores energy in the form of generalized displacement. For intrinsic stability, it is usually assumed that the function C satisfies $\frac{\partial C(q)}{\partial q} > 0$.
- A flow-source (bond graph symbol S_f), is a component with a constitutive relation $f = S_f$, such that the function S_f satisfies $\frac{\partial S_f}{\partial p} = 0$. Recall, that the value of S_f may depend on the value of variables other than p . A flow-source enforces a certain change in generalized displacement, and has an arbitrary generalized momentum at its disposition to achieve this.
- An effort-source (bond graph symbol S_e), is a component with a constitutive relation $e = S_e$, such that the function S_e satisfies $\frac{\partial S_e}{\partial q} = 0$. It enforces a certain change in generalized momentum, and has an arbitrary generalized displacement at its disposition to achieve this.

In table 2, we have summarized the analogies between the bond graph elements above (except for the sources), and what they represent in different fields in physics. In this table, we have assumed that the components are characterized by linear constitutive equations, and have also mentioned the (more or less) standard notations that are used in the different fields to denote variables and parameters. The linear equations are:

$$\begin{aligned} \text{Resistance} & : e = R(f) = R \cdot f \\ \text{Inductance} & : f = I(p) = \frac{1}{I} \cdot p \\ \text{Capacitance} & : e = C(q) = \frac{1}{C} \cdot q . \end{aligned}$$

In these equations, we have adopted the standard letters that are used in bond graph theory for the parameters of the linear equations. In the remainder of the report, we always use generic constitutive relations (denoted by small capital letters) in the development of the theory, and linear constitutive equations (with the parameters as defined above) in the examples, unless otherwise specified.

Table 2: Bond graph element analogies

	inductance I	capacitance C	resistance R
trans. mech.:	mass m	spring $\frac{1}{k}$	damper b
rot. mech.:	rot. inertia J	rot. spring $\frac{1}{k}$	rot. damper c
electronics:	inductor L	capacitor C	resistor R
hydraulics:	fluid-inertia I	reservoir C	resistor R

It is important to note, that not all variables are involved in the constitutive relations of every component. The constitutive relations of a resistance only deal with e and f , not with p and q . Also, the constitutive relations of an inductance deal with p and f , not with q and e , and vice versa for the capacitance. The variables that do not occur in the definition of a specific component, are considered to be auxiliary variables for that component. As it turns out, in some cases, these auxiliary variables do not even have a physical interpretation. In this report, we adopt the assumption that if the variables p and q occur as auxiliary variables, then they cannot engage in discontinuous behavior. The consequences of this, will become clear section 2.3.

When we draw a bond graph, a bond graph element is always drawn together with a half arrow (called a *bond*). This arrow represents the energy connection between the element and the rest of the system. A bond always points in the positive direction of power. In other words, if the flow and effort are both positive, the arrow points towards the element if it stores or dissipates energy (as is the case with inertia, capacitances and resistances), and away from the element if it supplies energy to the system (as is the case with sources of effort and flow). This is depicted in figure 2. It is important to verify that the choice of the directions of the bonds coincides with the

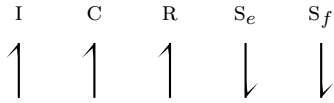

Figure 2: Power directions for standard bond graph elements

choice of positive directions in the model. For example, to make a bond graph that represents the mechanical system pictured in figure 1, we have to take care that the positive direction of velocity (in this case upward) coincides with the positive direction of power in the bond graph. In case of a conflict, it is usually possible to leave the power directions of figure 2 intact, and only change the direction of bonds between junctions.

A connection between a set C of components, that is based on conservation of generalized displacement, is called a 0-junction. Therefore, in a 0-junction, we have the equations (2) and (4). Additionally, we have the equation

$$e_c = e_{c'}, \text{ for all } c, c' \in C, \quad (5)$$

expressing that effort on all connected components is equal in all connected components. The 1-*junction* describes exchange of energy through exchange of generalized momentum. In a 1-junction, we have the equations (2) and (3), and additionally

$$f_c = f_{c'}, \text{ for all } c, c' \in C, \quad (6)$$

expressing that the flow through all connected components is equal. As before, one may observe that preservation of energy (2) follows from the combination of equations (1), (4) and (5), and also from the combination of (1), (3) and (6). In the description of physical system, preservation of energy is therefore, usually, considered implicit. Further on, we will see that in hybrid systems, it cannot be considered implicit anymore.

When there are elements connected to a junction of which the power directions point outward, they have a negative effect on the exchange of generalized momentum or generalized position. The equations given above, are therefore for the case where all bond arrows point inwards, into the junction. Some possible configurations, and the associated constitutive equations, have been depicted in figure 3.

To facilitate the creation of a set of constitutive relations for a bond graph model, each bond is usually given a unique number that is used as a subscript for all the variables associated with that bond. As an example, the mechanical system of figure 1 is turned into the bond graph of figure 4 as follows. Firstly, the position of the mass is defined relative to the position of the ground, while the position of the spring and damper refers to the amount with which they are stretched. The force F is connected to the mass, so their positions are equal. Secondly, we define a change of position in the upward direction to be positive. From figure 1, it is then clear, that a change in position of the mass, leads to an equal change in position of the force, the spring and the damper. This suggests a 1-junction between the bond graph elements representing these components. Thirdly, if

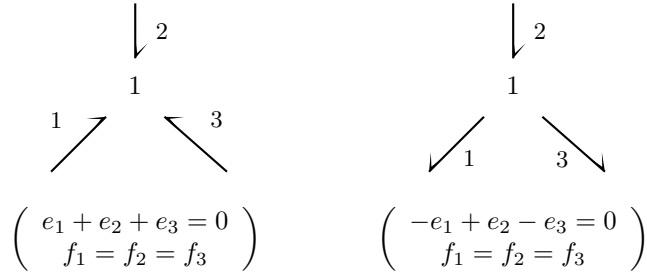

Figure 3: Constitutive equations for junctions with different power directions

we want the power directions of the bond graph elements to point in the directions given in figure 2, we need to define the direction of the force F , and the forces generated by the spring and the damper, to be positive in the upward direction. Lastly, because everything is modeled relative to the ground, it is not necessary to model the ground explicitly. We use linear constitutive relations for our components, and write the parameters that play a role in these linear relations near the bond graph elements, separated by a colon. Writing down the constitutive relations for this model,

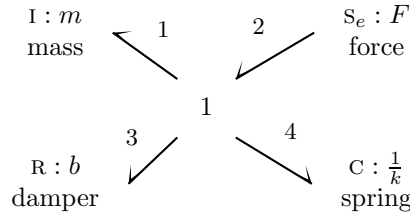

Figure 4: Bond graph for a mass-spring-damper system

and renaming the variables appropriately, indeed gives us the set of equations in figure 1.

2.3 Time-scale abstraction

In the first part of this section, we explained a general way of modeling continuous physical systems using a mass-spring-damper system as an example. In order to explain the need for time-scale abstraction and hybrid modeling, we study a different system, namely, a collision between two bodies, as depicted in figure 5.

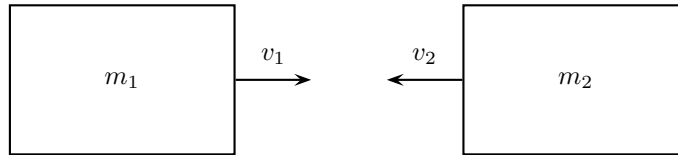

Figure 5: Two colliding bodies

In classical physics, there is the assumption that energy can only be transported from one point in time and space to another, by a continuous trajectory. This is also called the principle

of *continuity of power* and is attributed to the British physicist Oliver Heaviside [7]. A direct consequence of this principle, is that in the situation of figure 5, we cannot simply model the two colliding bodies as masses. The reason for this, is that the momentum of a mass determines its kinetic energy, which cannot change discontinuously. The model is inconsistent with respect to continuity of power. Indeed, if we wish to model the collision of bodies in a consistent way, we must model the way in which the energy is transferred more precisely. For example, we might model the bodies as masses that are momentarily connected via a spring-damper system at impact, as shown in figure 6. This reflects the elastic effects and the dissipation of energy that occur during impact.

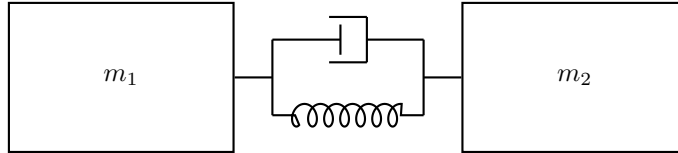

Figure 6: Power continuous model of two colliding bodies

However, for many modeling applications, the extension of a model to make it consistent with the principle of continuity of power is impractical. Due to its greater size, such a model may be harder to analyze, and, more importantly, not all parameters may be known for the components involved in the extension. In the example of the impact between bodies, the elasticity of the bodies, and the precise damping factors, may not be known. In such a situation, it may prove convenient to abstract from the exact behavior, and model it as a discontinuous change. Naturally, the modeler should verify that the abstraction from impact dynamics, is indeed a valid one with respect to the goal of the model.

Given the constitutive relations for continuous behavior, we can attempt to derive constitutive relations for discontinuous behavior. In these relations, we use x^- to denote the value of x before the discontinuity, and x^+ to denote the value of x afterwards. As a shorthand notation, we use x' for $(x^+ - x^-)$. Preservation of energy, for example, can be expressed as

$$\sum_{c \in C} (E_c^+ - E_c^-) = \sum_{c \in C} E_c' = 0 . \quad (7)$$

In general, discontinuous behavior is a result of a change in the connection structure between components. We are abstracting away from the precise behavior that happens during this change in structure. Note, that this behavior may include the dissipation of energy by the environment of the system. Due to a change in structure, some energy in the system may be thus be lost. Therefore, if there is a change in connection structure, we use the following equation for the energy of connected components.

$$\sum_{c \in C} E_c' \leq 0 . \quad (8)$$

For the derivation of the constitutive relations describing the discontinuous behavior of the components, we base ourselves on the descriptions of the continuous behavior. As it turns out, we can calculate the changes in stored energy, generalized displacement, and generalized momentum, for many of the components. However, if generalized displacement and generalized momentum occur as auxiliary variables, as mentioned in section 2.2, it is difficult to calculate changes, without knowledge of the exact amount of time that is abstracted away from. Therefore, in the derivations below, we have assumed that the change in these variables is negligible. The modeler needs to verify that this assumption is indeed justified, if the auxiliary variables have physical meaning! Further on, we will briefly discuss some examples of what can be done if this is not the case.

- For a *resistance*, the variables p and q are both auxiliary. Indeed, we cannot conclude from the constitutive relation $e = R(f)$ that $p' = R(q')$. The change in energy, generalized momentum and generalized position, depends on the precise behavior during the discontinuity. We therefore assume that resistances do not take part in the discontinuous behavior, and that $E' = q' = p' = 0$. As a result, the only dissipation during discontinuous behavior, is in the changing connection structure. Note, that for example in the mechanical domain, this means that the position q does not change during discontinuous behavior.
- For an *inductance* we have the continuous relation $\dot{E} = \dot{p} \cdot \dot{q} = \dot{p} \cdot I(p)$. We integrate over the trajectory of p to find $E' = \int_{p^-}^{p^+} I(x) dx$ for the change in stored energy as a function of the change in generalized momentum (see for example 5.4.2 in [6], for the substitution rule from differential calculus we used here). Furthermore, generalized displacement q is an auxiliary variable for an inductance. Therefore, we assume that $q' = 0$.
- For a *capacitance* we find, dual to the inductance, that $E' = \int_{q^-}^{q^+} c(x) dx$ and $p' = 0$.
- For a *flow-source*, we find that $E' = \int_{p^-}^{p^+} s_f dp = s_f \cdot (p^+ - p^-) = s_f \cdot p'$. Note, that these relations are similar to that of an inductance, apart from the fact that $\frac{\partial s_f}{\partial p} = 0$. As with inductances, we assume that $q' = 0$.
- For an *effort-source*, we find that $E' = \int_{q^-}^{q^+} s_e dq = s_e \cdot q'$. As with capacitances, we assume that $p' = 0$.

Note, that for example the calculation of the integral $E' = \int_{p^-}^{p^+} I(x) dx$, is only valid if I does not depend on other variables than x . If it does, we need to assume, at least, that the change in these other variables is negligible during the discontinuous behavior. Something that, again, has to be verified by the modeler.

For 0-junctions, we still have conservation of generalized displacement

$$\sum_{c \in C} q'_c = 0, \quad (9)$$

while all changes in generalized momentum are equal

$$p'_c = p'_{c'}, \text{ for all } c, c' \in C. \quad (10)$$

For 1-junctions we have conservation of generalized momentum

$$\sum_{c \in C} p'_c = 0, \quad (11)$$

while all changes in generalized displacement are equal

$$q'_c = q'_{c'}, \text{ for all } c, c' \in C. \quad (12)$$

Note, that it is not the case that $E' = p' \cdot q'$. Hence, the energy equation (7) can no longer be left implicit when describing junctions.

Using the constitutive relations for discontinuous behavior that we found above, we can model the impact of bodies shown in figure 5 as a discontinuous behavior of two masses. If we use the linear constitutive differential equation $\dot{q} = f = \frac{1}{m} \cdot p$ for the colliding bodies, with p the momentum, m the mass, q the position of the bodies, and f the velocity, we obtain the discontinuous constitutive relations given below, for the behavior at time of impact.

$$\begin{aligned} E'_1 + E'_2 &\leq 0 \\ p'_1 + p'_2 &= 0 \\ q'_1 &= q'_2 = 0 \\ E'_1 &= \int_{p_1^-}^{p_1^+} \left(\frac{1}{m_1} \cdot p\right) dp = \frac{(p_1^+)^2 - (p_1^-)^2}{2 \cdot m_1} \\ E'_2 &= \int_{p_2^-}^{p_2^+} \left(\frac{1}{m_2} \cdot p\right) dp = \frac{(p_2^+)^2 - (p_2^-)^2}{2 \cdot m_2} \end{aligned}$$

As a last remark, we would like to discuss the assumption we made earlier, that certain variables do not change during the discontinuous behavior. Especially, to get a feeling of the implications of this assumption, we would like to study three examples, of situations in which this assumption does not hold.

The first example, is that of a model of a discontinuous effort-source (think, for example, of a voltage source that can be switched on). In this model, the relation s_e changes during the discontinuity. Because of this, we cannot use the discontinuous constitutive relations derived above. The partial integral that is used there, is incorrect. However, if we add the assumption that the value of s_e stays within the bounds s_e^- and s_e^+ during the discontinuous behavior, we may still approximate the discontinuous behavior using the equations $E' \leq \min(s_e^-, s_e^+)q'$ and $E' \geq \max(s_e^-, s_e^+)q'$. This shows, that the assumption that the continuous constitutive relation s_e does not change, can be omitted if we have other assumptions to guide the construction of the discontinuous constitutive relations. Incidentally, a discontinuous effort-source can also be modeled using the bond graph elements discussed in section 4.6.

The second example, is that of an external force (or effort source), acting on one of the two colliding masses of figure 5. We know, from basic physics, that in such a case the law of conservation of momentum does not hold during the collision. Energy may be transferred from the effort source to the colliding masses. The change in the auxiliary variable p , associated with the effort source, models the way in which the change in momentum of the masses is influenced by the external force. Our assumption that auxiliary variables do not change ($p' = 0$), implies in this case that we consider the influence of the external force to be negligible. However, if the force is relatively large, or the masses are relatively small, this assumption may not hold. In that case, simply dropping the requirement that $p' = 0$, as we did in the previous example, leads to an arbitrary change in the velocity of the masses. This is clearly not desirable. We suspect, that in this situation it is not possible to model the impact as a discontinuous behavior.

The third, and last, example, is that of an extremely low, or high, resistance. If the value of a resistance approaches infinity, it is unlikely that a change in connection structure between components will be fast enough to prevent the dissipation of some energy in this resistance. Also, if the value of a resistance is close to zero, the assumption that there is no change in the value of the auxiliary variable q , is likely to be flawed. If we still want to model the behavior of the system discontinuously, we can replace the equation $E' = 0$ by $E' \geq 0$ and drop the requirement that $p' = 0$, in case of a high resistance. In case of a low resistance, we can drop the requirement that $q' = 0$. Modeling a resistor in this more flexible way, has the same drawback as in the previous example on the high external force in a collision. There may be behaviors introduced in the model, that are not actually possible in the physical system. This needs to be verified by the modeler, to be sure. Similar situations arise when a mass or elasticity approaches zero, and hence the associated inductance I or capacitance C approaches infinity. In this report, we will not consider the constitutive relations that are needed for those special cases any further, and stick to the assumption that the change in auxiliary variables and continuous constitutive relations is negligible during discontinuous behavior.

In section 4, we will combine the constitutive relations for continuous and discontinuous behavior into so-called hybrid constitutive processes. We will also describe bond graph elements that can be used for modeling a change in connection structure [9, 1, 12]. Before we can do so, however, we need to formalize the way in which we describe these combinations of continuous and discontinuous behavior. The formalism we use for this, is called hybrid process algebra (HyPA).

3 Hybrid process algebra

The hybrid process algebra HyPA (see [4] for a complete treatment), allows its user to write down models containing both continuous and discontinuous behavior of a system. The full algebra also allows for the modeling of software components, through abstract computational actions, but since this is outside the scope of this report, we will not discuss the constructs dealing with those here. In our discussion, we limit ourselves to the following signature of constants and function symbols:

1. flow clauses $(V | P_f)$,
2. process re-initializations $[V | P_r] \gg -$,
3. alternative composition $- \oplus -$,
4. disrupt $- \blacktriangleright -$, and
5. parallel composition $- || -$.

Terms in this signature will be used to describe process behavior, consisting of continuous flows and discontinuities, in the following way.

Continuous and discontinuous behavior are described using predicates over model variables \mathcal{V}_m . In this report, continuous behavior is described using flow predicates \mathcal{P}_f on the model variables \mathcal{V}_m and their time derivatives $\dot{\mathcal{V}}_m = \{\dot{x} \mid x \in \mathcal{V}_m\}$. Discontinuous behavior is described using re-initialization predicates \mathcal{P}_r on model variables signed with a minus \mathcal{V}_m^- , to denote conditions that only hold at the start of a re-initialization, and on model variables signed with a plus \mathcal{V}_m^+ , to denote conditions that hold only at the end of a re-initialization. As before, we write primed versions \mathcal{V}'_m of the model variables, denoting a difference in the value of model variables.

A flow clause is an atomic process that models the repeated execution of physical behavior. It is denoted as a pair $(V | P_f)$ of a set of model variables $V \subseteq \mathcal{V}_m$, signifying which variables are not allowed to jump in between flows, and a flow predicate $P_f \in \mathcal{P}_f$ modeling which flow behavior can be executed by the clause. A process re-initialization $[V | P_r] \gg p$ models the behavior of a process p where the model variables are first submitted to a discontinuous change. This change is specified by the set of model variables $V \subseteq \mathcal{V}_m$ and the re-initialization predicate P_r . In the case of process re-initializations, the set V models which variables are allowed to change. Note that this is precisely opposite to flow clauses. In this report, we will always explicitly model the changes that take place using re-initializations. Therefore, $V = \mathcal{V}_m$ in all flow-clauses and re-initialization clauses that are used. Since this is the case, we will not bother to write down V explicitly, and we write $[P_r]$ for $[\mathcal{V}_m | P_r]$ and (P_f) for $(\mathcal{V}_m | P_f)$.

The alternative composition $p \oplus q$ models a (non-deterministic) choice between the processes p and q . The disrupt $p \blacktriangleright q$ models that process q may take over execution from process p at any moment. In other words, it models a mode switch from p to q . The parallel composition $p || q$ models concurrent execution of p and q . For the restricted version of HyPA we use in this report, the intuition behind parallel composition is simply that processes synchronize the execution of their continuous and discontinuous behavior.

Finally, we can define more complex processes using recursive specifications $X \approx p$, where X is a process variable and p is a term possibly containing X and other process variables. Amongst others, recursion is a powerful way to express repetition in a process. Note that we use \approx to denote equivalence of processes, while $=$ is used in flow and re-initialization predicates.

The binding order of the operators of HyPA is as follows: \blacktriangleright , \gg , $||$, \oplus , where alternative composition binds weakest, and the disrupt binds strongest.

Hybrid process algebra allows us to write down a constitutive process for each element of a bond graph, describing its continuous behavior as well as its discontinuous behavior. As we will see in the next section, a constitutive process is always a process of the form

$$X \approx \left(\begin{array}{c} [\mathcal{V}_m \mid P_{r1}] \gg \left(\mathcal{V}_m \mid P_{f1} \right) \\ \oplus \dots \oplus \\ [\mathcal{V}_m \mid P_{rn}] \gg \left(\mathcal{V}_m \mid P_{fn} \right) \end{array} \right) \blacktriangleright X .$$

This models a repetitive choice on the execution of discontinuities followed by continuous behavior. For most elements, there is only one possible discontinuous and continuous behavior possible, which is repeated indefinitely. Only in the case of controlled junctions and switches there are more. A complete system is modeled as a parallel composition of constitutive processes, i.e.

$$S \approx X_0 \parallel \dots \parallel X_m .$$

We conjecture, without proof, that any parallel composition of constitutive processes as described in this report, can always be rewritten into the form of a constitutive process again. Note, however, this is not a trivial result, and that it is not true in general for the form given above. The formal details still have to be worked out.

Note, that it is not possible to execute several discontinuities consecutively without performing continuous behavior in between. This means that a physically feasible state must be reached after every discontinuity, and that no two consecutive discontinuities can occur. In principle, it is possible to allow singleton solutions to flow clauses in the semantics of HyPA. Singleton solutions are flows with the interval $[0, 0]$ as domain. This means that multiple discontinuities can occur without the passage of time in between. However, the definition of the notion of singleton solution is difficult for differential equations, because the derivative operator is not defined on a function with the interval $[0, 0]$ as domain. In this report, we do not consider those solutions. In the analysis of Newton's cradle in section 5.4, it becomes clear why this choice does not influence the behavior of our models severely.

4 Constitutive hybrid processes

In this section, we give a hybrid description of every element of the bond graph formalism as a constitutive hybrid process. We also give constitutive processes for the hybrid elements defined in [9, 1], that describe a changing connection structure between the elements of a bond graph. The parallel composition of constitutive hybrid processes leads to an algebraic description of the whole bond graph.

4.1 Bond

The main variables that we describe in our constitutive processes are the stored energy E , the generalized momentum p , the effort e , the generalized displacement q , and the flow f of an element. The standard relations between those variables are reflected in the constitutive process for a bond, although often, we leave those relations implicit for brevity of the presentation. Note, that a bond does not restrict the behavior during discontinuities, which is reflected in the re-initialization clause $[\mathcal{V}_m \mid true]$, or more concisely $[true]$. The subscript i refers to the labeling of the bond in the bond graph.

$$\text{Bond}_i \approx \left([true] \gg \left(\begin{array}{l} \dot{E}_i = e_i \cdot f_i \\ \dot{p}_i = e_i \\ \dot{q}_i = f_i \end{array} \right) \right) \blacktriangleright \text{Bond}_i$$

4.2 Resistance

A resistance models dissipation of energy. As we mentioned in 2.3, however, during discontinuous behavior, the dissipation of energy through resistors is assumed to be negligible. Hence, the energy of a resistance is not allowed to change discontinuously. Furthermore, also the generalized momentum and displacement are considered to be auxiliary variables, and are not allowed to change. The continuous behavior is described using the constitutive relation $e = R(f)$, for which we assume that $x \cdot R(x) \geq 0$ for every x . This ensures that a resistor models dissipation of energy $\dot{E} \geq 0$.

$$\text{Resistance}_i(\mathbf{R}) \approx \left(\left[\begin{array}{l} E'_i = 0 \\ p'_i = 0 \\ q'_i = 0 \end{array} \right] \gg \left(e_i = R(f_i) \right) \right) \blacktriangleright \text{Resistance}_i(\mathbf{R}).$$

4.3 Inductance and capacitance

As was already explained in 2.3, the generalized position of an inductance is considered an auxiliary variable, and is not allowed to change during discontinuous behavior. The generalized momentum of an inductance always has a physical interpretation, and may therefore change arbitrarily. The change in stored energy is determined by the momentum-integral over the constitutive relation. The continuous behavior of an inductance is described by the equation $f_i = I(p_i)$, where $\frac{\partial I(p_i)}{\partial p_i} > 0$. The modeler should verify that the relation $I(p_i)$, and the value of q_i , do not change significantly during discontinuous behavior.

$$\text{Inductance}_i(\mathbf{I}) \approx \left(\left[\begin{array}{l} E'_i = \int_{p_i^-}^{p_i^+} I(x) dx \\ q'_i = 0 \end{array} \right] \gg \left(f_i = I(p_i) \right) \right) \blacktriangleright \text{Inductance}_i(\mathbf{I}).$$

A capacitance is the dual of an inductance, regarding generalized momentum and generalized displacement, and so we reason that its constitutive process must be:

$$\text{Capacitance}_i(\mathbf{C}) \approx \left(\left[\begin{array}{l} E'_i = \int_{q_i^-}^{q_i^+} C(x) dx \\ p'_i = 0 \end{array} \right] \gg \left(e_i = C(q_i) \right) \right) \blacktriangleright \text{Capacitance}_i(\mathbf{C}),$$

with $\frac{\partial C(q_i)}{\partial q_i} > 0$.

4.4 Sources

For a flow source we have the constitutive relation $f = S_f$, while for an effort source we have $e = S_e$. For these relations, we require $\frac{\partial S_f}{\partial p} = 0$ and $\frac{\partial S_e}{\partial q} = 0$. The modeler should verify, that the relations S_f and S_e , and the auxiliary variables q_i , for a flow source, and p_i , for an effort source, do not change significantly during discontinuous behavior. In particular, this means that we cannot model discontinuous sources, using the constitutive hybrid process below. In section 2.3, we discussed an alternative constitutive description that is fit for modeling discontinuous sources. Also, the controlled junctions in section 4.6 may be used for this.

$$\text{Flow-Source}_i(S_f) \approx \left(\left[\begin{array}{l} E'_i = S_f \cdot p'_i \\ q'_i = 0 \end{array} \right] \gg \left(f_i = S_f \right) \right) \blacktriangleright \text{Flow-Source}_i(S_f).$$

$$\text{Effort-Source}_i(S_e) \approx \left(\left[\begin{array}{l} E'_i = S_e \cdot q'_i \\ p'_i = 0 \end{array} \right] \gg \left(e_i = S_e \right) \right) \blacktriangleright \text{Effort-Source}_i(S_e).$$

4.5 Junctions

As before, the 0-junction represents conservation of total energy and total generalized displacement at an equal change in generalized momentum. Dually, the 1-junction represents conservation of total energy and total generalized momentum at an equal change in generalized displacement. The discontinuous behavior is such that total generalized momentum and total generalized displacement are still preserved or changing equally, respectively, and that also the total energy in the system is preserved. Later, when we study junctions that display switching behavior, we will find examples of a junction in which energy is dissipated during discontinuous behavior.

Bear in mind, that the positive direction of power, determines the sign of the contribution of variables to the summations, as in the explanation of junctions in section 2.2. This is also the case for the summation of energy. To emphasize this, we have used the notation \pm in front of every variable that should be positive when the the power direction points inward and negative when outward.

$$\begin{aligned}
 \text{0-junction}_C &\approx \left(\left[\begin{array}{l} \sum_{c \in C} \pm E'_c = 0 \\ \sum_{c \in C} \pm q'_c = 0 \\ \forall_{c, c' \in C} p'_c = p'_{c'} \end{array} \right] \gg \left(\begin{array}{l} \sum_{c \in C} \pm f_c = 0 \\ \forall_{c, c' \in C} e_c = e_{c'} \end{array} \right) \right) \blacktriangleright \text{0-junction}_C, \\
 \text{1-junction}_C &\approx \left(\left[\begin{array}{l} \sum_{c \in C} \pm E'_c = 0 \\ \sum_{c \in C} \pm p'_c = 0 \\ \forall_{c, c' \in C} q'_c = q'_{c'} \end{array} \right] \gg \left(\begin{array}{l} \sum_{c \in C} \pm e_c = 0 \\ \forall_{c, c' \in C} f_c = f_{c'} \end{array} \right) \right) \blacktriangleright \text{1-junction}_C.
 \end{aligned}$$

4.6 Controlled junctions and switches

In this section, we discuss several hybrid bond graph elements, as they were proposed earlier in literature. The controlled junctions are based on the work of [9, 1]. The switching element, was proposed in [12]. As we will see further on, we can express the switch in terms of controlled junctions and 0-sources.

When active, a controlled junction acts like the junction it is associated with. When inactive, it acts like a collection of 0-effort sources or a collection of 0-flow sources, depending on the specific type of the controlled junction. The 0/E, and 1/E type act as an effort source when inactive, while the 0/F and 1/F type act as a flow source. The predicates Act and Inact, model when a controlled junction is active or inactive, respectively. These are predicates over \mathcal{V}_m only. We use Act^- to denote the predicate Act where all variables $x \in \mathcal{V}_m$ are replaced by x^- , and similarly for Inact^- .

As we explained in section 2.3, a change in connection structure between components may give rise to a dissipation of energy. Therefore, when switching from Act to Inact, or vice versa, we allow a decrease in the total energy of the system. The discontinuous behavior of the other variables during this decrease, is governed by either the equations for the discontinuous behavior of the associated junction or the equations for the 0-effort or flow-source. Since we are switching from one mode to another, both are possible. Note, that due to the sign convention, a decrease in energy in the system, is associated with a positive change in total energy in the junction. In the equations below, we use the same notation (\pm) as with junctions, to emphasize the dependence of signs on the power direction of the bonds.

We obtain the following hybrid constitutive process for the (0/E)-junction.

$$\begin{aligned}
(0/E)_C(\text{Act}, \text{Inact}) &\approx \left(\left[\begin{array}{l} \text{Act}^- \\ \sum_{c \in C} \pm E'_c = 0 \\ \sum_{c \in C} \pm q'_c = 0 \\ \forall_{c, c' \in C} p'_c = p'_{c'} \end{array} \right] \gg \left(\begin{array}{l} \text{Act} \\ \sum_{c \in C} \pm f_c = 0 \\ \forall_{c, c' \in C} e_c = e_{c'} \end{array} \right) \right) \\
&\oplus \left[\begin{array}{l} \text{Inact}^- \\ \forall_{c \in C} \left\{ \begin{array}{l} E'_c = 0 \\ p'_c = 0 \end{array} \right. \end{array} \right] \gg \left(\begin{array}{l} \text{Inact} \\ \forall_{c \in C} e_c = 0 \end{array} \right) \\
&\oplus \left[\begin{array}{l} \text{Inact}^- \\ \sum_{c \in C} \pm E'_c \geq 0 \\ \sum_{c \in C} \pm q'_c = 0 \\ \forall_{c, c' \in C} p'_c = p'_{c'} \end{array} \right] \gg \left(\begin{array}{l} \text{Act} \\ \sum_{c \in C} \pm f_c = 0 \\ \forall_{c, c' \in C} e_c = e_{c'} \end{array} \right) \\
&\oplus \left[\begin{array}{l} \text{Act}^- \\ \sum_{c \in C} \pm E'_c \geq 0 \\ \sum_{c \in C} \pm q'_c = 0 \\ \forall_{c, c' \in C} p'_c = p'_{c'} \end{array} \right] \gg \left(\begin{array}{l} \text{Inact} \\ \forall_{c \in C} e_c = 0 \end{array} \right) \\
&\oplus \left[\begin{array}{l} \text{Inact}^- \\ \forall_{c \in C} \left\{ \begin{array}{l} \pm E'_c \geq 0 \\ p'_c = 0 \end{array} \right. \end{array} \right] \gg \left(\begin{array}{l} \text{Act} \\ \sum_{c \in C} \pm f_c = 0 \\ \forall_{c, c' \in C} e_c = e_{c'} \end{array} \right) \\
&\oplus \left[\begin{array}{l} \text{Act}^- \\ \forall_{c \in C} \left\{ \begin{array}{l} \pm E'_c \geq 0 \\ p'_c = 0 \end{array} \right. \end{array} \right] \gg \left(\begin{array}{l} \text{Inact} \\ \forall_{c \in C} e_c = 0 \end{array} \right) \\
\blacktriangleright (0/E)_C(\text{Act}, \text{Inact})
\end{aligned}$$

It is straightforward to construct the dual definitions for 1/E, 0/F and 1/F. Some of the re-initialization clauses that are used above, may be combined using the equivalence $d \gg x \oplus d' \gg x \approx (d \vee d') \gg x$ (which is one of the axioms of HyPA [4]). We presented the constitutive hybrid process in the disjunctive way, to put more emphasis on the structure of the process.

A switch, acts like a 0-effort source when active, and as a 0-flow source when inactive. As before, when switching modes, energy may be dissipated while the other variables behave according to the equations of one of the sources. Because the power bond of a switch is always pointing outward, the decrease in energy is associated with the constitutive equation $(E_i^+ - E_i^-) \leq 0$. The constitutive

hybrid process of a switch has a similar structure as that of a controlled junction.

$$\begin{aligned}
\text{Switch}_i(\text{Act}, \text{Inact}) &\approx \left(\left[\begin{array}{c} \text{Act}^- \\ E'_i = 0 \\ p'_i = 0 \end{array} \right] \gg \left(\begin{array}{c} \text{Act} \\ e_i = 0 \end{array} \right) \right. \\
&\oplus \left[\begin{array}{c} \text{Inact}^- \\ E'_i = 0 \\ q'_i = 0 \end{array} \right] \gg \left(\begin{array}{c} \text{Inact} \\ f_i = 0 \end{array} \right) \\
&\oplus \left[\begin{array}{c} \text{Inact}^- \\ E'_i \leq 0 \\ p'_i = 0 \end{array} \right] \gg \left(\begin{array}{c} \text{Act} \\ e_i = 0 \end{array} \right) \\
&\oplus \left[\begin{array}{c} \text{Act}^- \\ E'_i \leq 0 \\ p'_i = 0 \end{array} \right] \gg \left(\begin{array}{c} \text{Inact} \\ f_i = 0 \end{array} \right) \\
&\oplus \left[\begin{array}{c} \text{Inact}^- \\ E'_i \leq 0 \\ q'_i = 0 \end{array} \right] \gg \left(\begin{array}{c} \text{Act} \\ e_i = 0 \end{array} \right) \\
&\oplus \left. \left[\begin{array}{c} \text{Act}^- \\ E'_i \leq 0 \\ q'_i = 0 \end{array} \right] \gg \left(\begin{array}{c} \text{Inact} \\ f_i = 0 \end{array} \right) \right) \\
\blacktriangleright &\text{Switch}_i(\text{Act}, \text{Inact})
\end{aligned}$$

Note, that a switch can also be represented as a 0-effort source acting on a controlled 1/F-junction. Dually, representing a switch as a 0-flow source acting on a controlled 0/E-junction (with the switching predicates reversed), is also possible of course. We find that the three bond graphs depicted in figure 7 are equivalent, if we abstract from the variables associated with bonds 2 and 3.

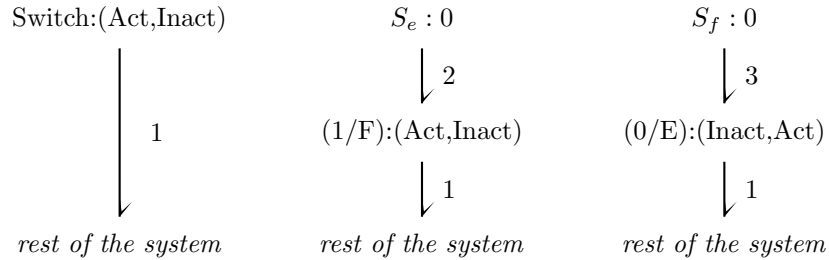

Figure 7: Three equivalent switches

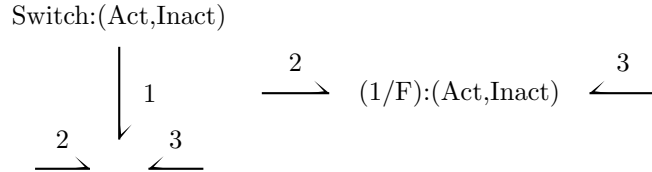

Figure 8: Two non-equivalent switches

The two bond graphs depicted in figure 8, perhaps surprisingly, are not equivalent. In the left bond graph, there is a situation where the total energy of bonds 2 and 3 may decrease, while the

switch acts like a 0-effort source. Still, some energy may go from 2 to 3, or vice versa. Using calculations, we obtain the following subprocess:

$$\left[\begin{array}{l} \text{Act} \\ E_2 + E_3 = -E'_1 \geq 0 \\ q'_1 = q'_2 = q'_3 = 0 \end{array} \right] \gg \left(\begin{array}{l} \text{Inact} \\ f_2 = f_3 = 0 \end{array} \right)$$

In the right bond graph, given that same situation, the energy of each of the bonds, separately, has to decrease, clearly indicating that the elements are disconnected. We find the subprocess:

$$\left[\begin{array}{l} \text{Act} \\ E'_2 \geq 0 \\ E'_3 \geq 0 \\ q'_2 = q'_3 = 0 \end{array} \right] \gg \left(\begin{array}{l} \text{Inact} \\ f_2 = f_3 = 0 \end{array} \right)$$

This detail makes that we have a slight preference for the use of controlled junctions over switching elements. However, the physical consequences of each have to be investigated in more detail still, so no fixed answer can be given yet to which is better. In the examples we give further on, we will only use the controlled junctions to model discontinuities in our systems.

Intermezzo For standard bond graph theory, there is a set of graph reduction rules, that lead to equivalent bond graphs (modulo elimination of variables associated with connections between junctions) [3]. We conjecture, that those rules are still valid for the hybrid case, with the exception that special elements, like resistors of value 0, and infinite resistances, inductances and capacitances, need special treatment due to the observations made at the end of section 2.3. For the formal derivation of bond graph reduction rules, we need a notion of abstraction from continuous variables in HyPA. Such a notion of abstraction is currently being developed. Using this notion, also new rules for dealing with hybrid elements, like the informal rule of figure 7, can be developed. Even without these abstraction rules, we can prove, for example, that $1\text{-junction}_C = (1/E)_C(\text{true}, \text{false})$, which illustrates that a controlled junction behaves like an ordinary junction if it is always activated.

4.7 Transformers and gyrators

Two standard bond graph elements that have not been discussed so far, are the transformer and the gyrator. They are used to model conversion between different physical domains. Examples are motors, levers, pumps etc. Transformers and gyrators always define a certain ratio M between the flow and effort on the one, and on the other side of the element. As before, the modeler should verify that this ratio does not change significantly during discontinuous behavior. The sign contribution on variables used in transformers and gyrators, depends on the positive direction of power. In the case of transformers and gyrators, all variables are negated when the direction of power of a certain bond is outward.

$$\text{Transformer}_{\{i,j\}}(M) \approx \left(\left[\begin{array}{l} \pm E'_i \pm E'_j = 0 \\ \pm p'_i = M \cdot \pm p'_j \\ \pm q'_j = M \cdot \pm q'_i \end{array} \right] \gg \left(\begin{array}{l} \pm e_i = M \cdot \pm e_j \\ \pm f_j = M \cdot \pm f_i \end{array} \right) \right) \blacktriangleright \text{Transformer}_{\{i,j\}}(M),$$

$$\text{Gyrator}_{\{i,j\}}(M) \approx \left(\left[\begin{array}{l} \pm E'_i \pm E'_j = 0 \\ \pm p'_i = M \cdot \pm q'_j \\ \pm p'_j = M \cdot \pm q'_i \end{array} \right] \gg \left(\begin{array}{l} \pm e_i = M \cdot \pm f_j \\ \pm e_j = M \cdot \pm f_i \end{array} \right) \right) \blacktriangleright \text{Gyrator}_{\{i,j\}}(M).$$

5 Examples

In this section, we will discuss several examples of hybrid modeling, and the resulting process algebraic descriptions. We start by revisiting the collision example of section 2.3, and subsequently apply the same principle in a model of an impact control unit as produced by Assembleon and Philips CFT. Next, we study a model of an electrical circuit containing diodes, and show how, in this model, implicit switching takes place, leading to a model with less modes of operation than one might expect on first sight. Subsequently, we perform a deeper study of the phenomenon of implicit switching, using a model of Newton's cradle. Lastly, we give a model of a vacuum chamber, as it is produced by ASML, and suggest a specification of a safe controller for this system. In all models, except that of the vacuum chamber, we use linear constitutive equations for all components.

5.1 Collision

In this subsection, we revisit the example of a collision between two masses of section 2.3. The bond graph that is associated with the problem of collision, is depicted in figure 9.

The controlled 1/E-junction is active, modeling the exchange of momentum between the two masses, when the position of the masses is equal, and either the velocity of the left mass is greater than that of the right mass, or the velocities are equal and the acceleration of the left mass is greater than that of the right mass. The acceleration of an inductance can be expressed as $\dot{f} = \frac{\partial I}{\partial t}(p) + I(\dot{p})$, and for the linear masses we use in this model we find $\dot{f} = \frac{1}{m} \cdot e$. Ultimately, we obtain $(q_1 = q_2 \wedge f_1 > f_2) \vee (q_1 = q_2 \wedge f_1 = f_2 \wedge \frac{1}{m_1} \cdot e_1 \geq \frac{1}{m_2} \cdot e_2)$ for the Act predicate. For the Inact predicate, modeling the case where the masses do not touch, we have $(q_1 \leq q_2)$, expressing that the first mass cannot get past the second.

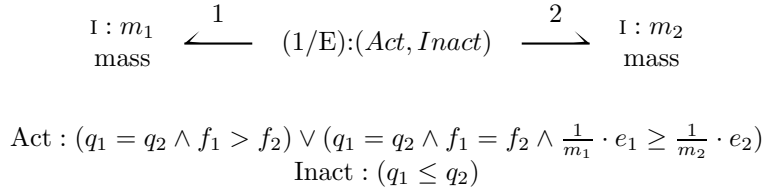

Figure 9: Modified bond graph for a collision

From this bond graph, we construct the following parallel composition of constitutive processes.

$$\text{Collision} \approx \text{Bond}_1 \parallel \text{Inductance}_1(m_1) \parallel (1/E)_{\{1,2\}}(Act, Inact) \parallel \text{Bond}_2 \parallel \text{Inductance}_2(m_2)$$

Elimination of the parallel composition through algebraic reasoning (see [4]), gives us the following constitutive process for the whole system. For the sake of brevity, we have left the bond

definitions implicit.

$$\begin{aligned}
\text{Collision} &\approx \\
&\left(\begin{array}{l} E'_1 = \frac{(p_1^+)^2 - (p_1^-)^2}{2 \cdot m_1} \\ E'_2 = \frac{(p_2^+)^2 - (p_2^-)^2}{2 \cdot m_2} \\ E'_1 + E'_2 = 0 \\ p'_1 + p'_2 = 0 \\ q'_1 = q'_2 = 0 \\ \text{Act}^- \end{array} \right) \gg \left(\begin{array}{l} p_1 = m_1 \cdot f_1 \\ p_2 = m_2 \cdot f_2 \\ e_1 + e_2 = 0 \\ f_1 = f_2 \\ \text{Act} \end{array} \right) \oplus \\
&\left(\begin{array}{l} E'_1 = E'_2 = 0 \\ p'_1 = p'_2 = 0 \\ q'_1 = q'_2 = 0 \\ \text{Inact}^- \end{array} \right) \gg \left(\begin{array}{l} p_1 = m_1 \cdot f_1 \\ p_2 = m_2 \cdot f_2 \\ e_1 = e_2 = 0 \\ \text{Inact} \end{array} \right) \oplus \\
&\left(\begin{array}{l} E'_1 = \frac{(p_1^+)^2 - (p_1^-)^2}{2 \cdot m_1} \\ E'_2 = \frac{(p_2^+)^2 - (p_2^-)^2}{2 \cdot m_2} \\ E'_1 + E'_2 \leq 0 \\ p'_1 + p'_2 = 0 \\ q'_1 = q'_2 = 0 \\ \text{Inact}^- \end{array} \right) \gg \left(\begin{array}{l} p_1 = m_1 \cdot f_1 \\ p_2 = m_2 \cdot f_2 \\ e_1 + e_2 = 0 \\ f_1 = f_2 \\ \text{Act} \end{array} \right) \oplus \\
&\left(\begin{array}{l} E'_1 = \frac{(p_1^+)^2 - (p_1^-)^2}{2 \cdot m_1} \\ E'_2 = \frac{(p_2^+)^2 - (p_2^-)^2}{2 \cdot m_2} \\ E'_1 + E'_2 \leq 0 \\ p'_1 + p'_2 = 0 \\ q'_1 = q'_2 = 0 \\ \text{Act}^- \end{array} \right) \gg \left(\begin{array}{l} p_1 = m_1 \cdot f_1 \\ p_2 = m_2 \cdot f_2 \\ e_1 = e_2 = 0 \\ \text{Inact} \end{array} \right) \\
&\blacktriangleright \text{Collision} .
\end{aligned}$$

In the next subsection, we will use the same principle of modeling collision, in a slightly more advanced model of an impact control module as used in a component mounting machine produced by Assembleon and Philips CFT.

5.2 Impact control at Assembleon

In this subsection, we discuss an application of the collision model to a real-life example. Assembleon is working on the design of a component mounting machine, for placing electrical components on a printed circuit board (PCB). Typically, the goal is to bring a component as fast as possible to the PCB, and then press it on the PCB for a sufficient time, with sufficient force, to make the adherent that is used for connection stick. In the actual mounting machine a number of components can be placed at the same time, using several impact modules. A simplified model of one such an impact module is drawn in figure 10. Because the nature of the components and the PCB's that are used varies wildly, it is not desirable to model the impact in too great detail. However, one of the requirements on the module is to prevent cracking of the component. Therefore, it is necessary to model the amount of energy that is absorbed during the actual impact of the component on the PCB.

The bond graph that is associated with the schematic model of figure 10 is given in figure 11. It is important to note, that this bond graph model is only valid, if the influence of the external force, and the influence of the spring damper system on the impact behavior, are indeed negligible. The actual validation of that assumption, is outside the scope of this report.

Note, that the power directions in the bond graph suggest that the velocity of the masses and the positive direction of the force are defined upward. In other words, the force vector in figure 10 is drawn in the negative direction. Furthermore, the switching conditions are slightly different from those in the previous section. Because we need to calculate the difference in acceleration as

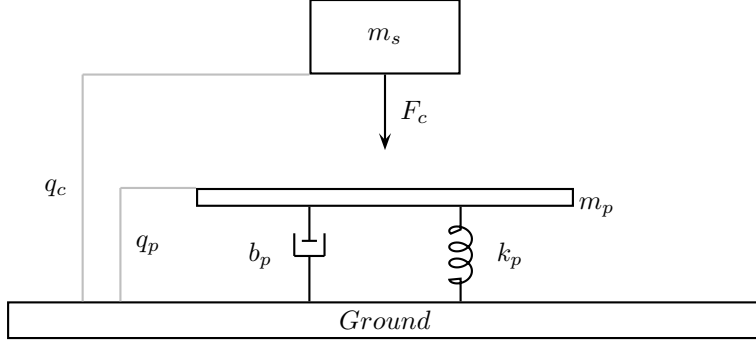

Figure 10: Schematic model of the impact module

it would have been if the junction were inactive, we have to take the effort that flows through the $(1/E)$ -junction into account. The resulting condition, admittedly, is rather complex. This seems to arise from the physical intuition that a system always takes the route of the least resistance. In this case, the impact system seems to have a preference for the case where there is no connection between the masses. In process algebra, such a preference is usually modeled using a choice operator that has a preference for one of its arguments. However, such an operator has not been developed yet for HyPA, so the use of it in constitutive hybrid processes is a topic for future research.

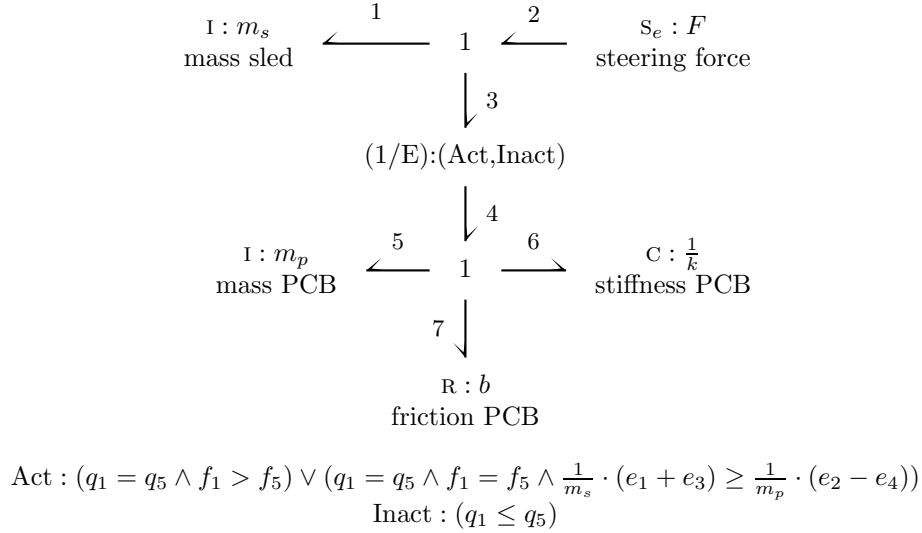

Figure 11: Bond graph model for the impact module

After calculations that are similar to the ones used in the previous subsection, we obtain the following constitutive hybrid process for the impact module as a whole. Note, that this process has roughly the same structure as the one we found in the previous section.

$$\begin{array}{l}
\text{Module } \approx \\
\left[\begin{array}{l} E'_1 = -E'_3 = \frac{(p_1^+)^2 - (p_1^-)^2}{2 \cdot m_s} \\ E'_4 = E'_5 = \frac{(p_5^+)^2 - (p_5^-)^2}{2 \cdot m_p} \\ E_1 + E_5 = E_2 = E_6 = E_7 = 0 \\ p_1 = -p_3 \\ p_4 = p_5 \\ p_1 + p_5 = p_2 = p_6 = p_7 = 0 \\ q_1 = q_2 = q_3 = q_4 = q_5 = q_6 = q_7 = 0 \\ \text{Act}^- \end{array} \right] \gg \left(\begin{array}{l} p_1 = m_s \cdot f_1 \\ p_5 = m_p \cdot f_5 \\ q_6 = \frac{1}{k} \cdot e_6 \\ e_2 = F \\ e_7 = b \cdot f_7 \\ e_2 - e_1 = e_3 = e_4 = e_5 + e_6 + e_7 \\ f_1 = f_2 = f_3 = f_4 = f_5 = f_6 = f_7 \\ \text{Act} \end{array} \right) \oplus \\
\left[\begin{array}{l} E'_1 = E'_2 = E'_3 = E'_4 = E'_5 = E'_6 = E'_7 = 0 \\ p'_1 = p'_2 = p'_3 = p'_4 = p'_5 = p'_6 = p'_7 = 0 \\ q'_1 = q'_2 = q'_3 = q'_4 = q'_5 = q'_6 = q'_7 = 0 \\ \text{Inact}^- \end{array} \right] \gg \left(\begin{array}{l} p_1 = m_s \cdot f_1 \\ p_5 = m_p \cdot f_5 \\ q_6 = \frac{1}{k} \cdot e_6 \\ e_2 = F \\ e_7 = b \cdot f_7 \\ e_2 - e_1 = e_3 = 0 \\ e_4 = e_5 + e_6 + e_7 = 0 \\ f_1 = f_2 = f_3 \\ f_4 = f_5 = f_6 = f_7 \\ \text{Inact} \end{array} \right) \oplus \\
\left[\begin{array}{l} E'_1 = -E'_3 = \frac{(p_1^+)^2 - (p_1^-)^2}{2 \cdot m_s} \\ E'_4 = E'_5 = \frac{(p_5^+)^2 - (p_5^-)^2}{2 \cdot m_p} \\ E_1 + E_5 \leq E_2 = E_6 = E_7 = 0 \\ p_1 = -p_3 \\ p_4 = p_5 \\ p_1 + p_5 = p_2 = p_6 = p_7 = 0 \\ q_1 = q_2 = q_3 = q_4 = q_5 = q_6 = q_7 = 0 \\ \text{Inact}^- \end{array} \right] \gg \left(\begin{array}{l} p_1 = m_c \cdot f_1 \\ p_5 = m_p \cdot f_5 \\ q_6 = \frac{1}{k} \cdot e_6 \\ e_2 = F \\ e_7 = b \cdot f_7 \\ e_2 - e_1 = e_3 = e_4 = e_5 + e_6 + e_7 \\ f_1 = f_2 = f_3 = f_4 = f_5 = f_6 = f_7 \\ \text{Act} \end{array} \right) \oplus \\
\left[\begin{array}{l} E'_1 = -E'_3 = \frac{(p_1^+)^2 - (p_1^-)^2}{2 \cdot m_s} \\ E'_4 = E'_5 = \frac{(p_5^+)^2 - (p_5^-)^2}{2 \cdot m_p} \\ E_1 + E_5 \leq E_2 = E_6 = E_7 = 0 \\ p_1 = -p_3 \\ p_4 = p_5 \\ p_1 + p_5 = p_2 = p_6 = p_7 = 0 \\ q_1 = q_2 = q_3 = q_4 = q_5 = q_6 = q_7 = 0 \\ \text{Act}^- \end{array} \right] \gg \left(\begin{array}{l} p_1 = m_c \cdot f_1 \\ p_5 = m_p \cdot f_5 \\ q_6 = \frac{1}{k} \cdot e_6 \\ e_2 = F \\ e_7 = b \cdot f_7 \\ e_2 - e_1 = e_3 = 0 \\ e_4 = e_5 + e_6 + e_7 = 0 \\ f_1 = f_2 = f_3 \\ f_4 = f_5 = f_6 = f_7 \\ \text{Inact} \end{array} \right)
\end{array}$$

► Module .

5.3 An electrical circuit

In this section, we study the electrical circuit depicted in figure 12. The bond graph that is associated with this circuit, is depicted in figure 13. It is taken from [10], and uses controlled junctions to model the electrical switch and the diode. The state of the diode depends on the flow and effort in the bond, or bonds, connected to it. For the electrical switch, we use the predicate Closed to represent a closed switch, and the predicate Open to represent an open switch.

After calculation on the parallel composition of constitutive hybrid processes of the bond graph depicted in figure 13, it turns out that there are essentially six possible re-initializations, and four possible flow clauses. Furthermore, the switching predicates restrict the combination of those. We

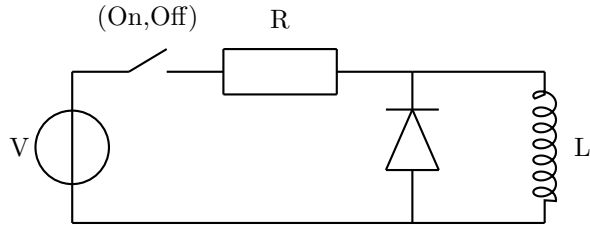

Figure 12: Electrical circuit with switch and diode

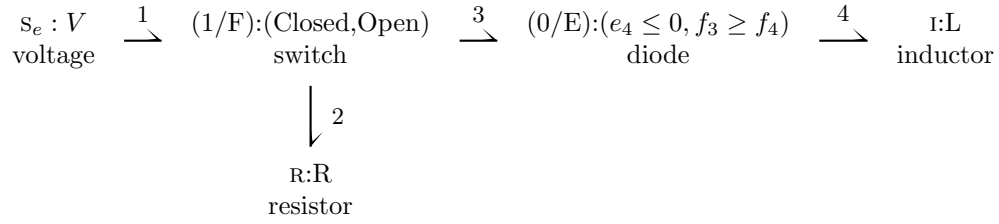

Figure 13: Bond graph model using controlled junctions

obtain the following constitutive process for the whole circuit.

$$\begin{aligned}
\text{Circuit} &\approx ((d_1 \wedge [f_3^- \geq f_4^-] \wedge [\text{Closed}^-]) \gg c_1 \\
&\oplus (d_1 \wedge [f_3^- \geq f_4^-] \wedge [\text{Closed}^-]) \gg c_2 \\
&\oplus (d_3 \wedge [f_3^- \geq f_4^-] \wedge [\text{Closed}^-]) \gg c_3 \\
&\oplus (d_4 \wedge [f_3^- \geq f_4^-] \wedge [\text{Closed}^-]) \gg c_4 \\
&\oplus (d_1 \wedge [f_3^- \geq f_4^-] \wedge [\text{Open}^-]) \gg c_1 \\
&\oplus (d_1 \wedge [f_3^- \geq f_4^-] \wedge [\text{Open}^-]) \gg c_2 \\
&\oplus (d_4 \wedge [f_3^- \geq f_4^-] \wedge [\text{Open}^-]) \gg c_3 \\
&\oplus (d_1 \wedge [f_3^- \geq f_4^-] \wedge [\text{Open}^-]) \gg c_4 \\
&\oplus (d_3 \wedge [e_4^- \leq 0] \wedge [\text{Closed}^-]) \gg c_1 \\
&\oplus (d_4 \wedge [e_4^- \leq 0] \wedge [\text{Closed}^-]) \gg c_2 \\
&\oplus (d_2 \wedge [e_4^- \leq 0] \wedge [\text{Closed}^-]) \gg c_3 \\
&\oplus (d_5 \wedge [e_4^- \leq 0] \wedge [\text{Closed}^-]) \gg c_4 \\
&\oplus (d_4 \wedge [e_4^- \leq 0] \wedge [\text{Open}^-]) \gg c_1 \\
&\oplus (d_1 \wedge [e_4^- \leq 0] \wedge [\text{Open}^-]) \gg c_2 \\
&\oplus (d_5 \wedge [e_4^- \leq 0] \wedge [\text{Open}^-]) \gg c_3 \\
&\oplus (d_1 \wedge [e_4^- \leq 0] \wedge [\text{Open}^-]) \gg c_4) \\
&\blacktriangleright \text{Circuit}
\end{aligned}$$

in which we use the following abbreviations, for which the bond definitions are left implicit:

$$\begin{aligned}
d_1 &= \left[\begin{array}{l} E'_1 = E'_2 = E'_3 = E'_4 = 0 \\ p'_1 = p'_2 = p'_3 = p'_4 = 0 \\ q'_1 = q'_2 = q'_3 = q'_4 = 0 \end{array} \right] & d_2 &= \left[\begin{array}{l} E'_1 = E'_2 = E'_3 = E'_4 = 0 \\ p'_1 = p'_2 = 0 \\ p'_3 = p'_4 \\ q'_1 = q'_2 = q'_3 = q'_4 = 0 \\ (p_4^+)^2 = (p_4^-)^2 \end{array} \right] \\
d_3 &= \left[\begin{array}{l} E'_1 = E'_2 = 0 \\ E'_3 = E'_4 = \frac{(p_4^+)^2 - (p_4^-)^2}{2 \cdot L} \leq 0 \\ p'_1 = p'_2 = 0 \\ p'_3 = p'_4 \\ q'_1 = q'_2 = q'_3 = q'_4 = 0 \end{array} \right] & d_4 &= \left[\begin{array}{l} E'_1 = E'_2 = 0 \\ E'_4 = \frac{(p_4^+)^2 - (p_4^-)^2}{2 \cdot L} \leq E_3 \leq 0 \\ p'_1 = p'_2 = 0 \\ p'_3 = p'_4 \\ q'_1 = q'_2 = q'_3 = q'_4 = 0 \end{array} \right] \\
d_5 &= \left[\begin{array}{l} E'_1 = E'_2 = E'_3 = 0 \\ E'_4 = \frac{(p_4^+)^2 - (p_4^-)^2}{2 \cdot L} \leq 0 \\ p'_1 = p'_2 = 0 \\ p'_3 = p'_4 \\ q'_1 = q'_2 = q'_3 = q'_4 = 0 \end{array} \right] \\
c_1 &= \left(\begin{array}{l} e_1 - e_2 = e_3 = e_4 \\ f_1 = f_2 = f_3 = f_4 \\ e_1 = V \\ e_2 = R \cdot f_2 \\ p_4 = \frac{1}{L} \cdot f_4 \\ e_4 \leq 0 \wedge \text{Closed} \end{array} \right) & c_2 &= \left(\begin{array}{l} e_2 = e_3 = e_4 \\ f_1 = f_2 = f_3 = f_4 = 0 \\ e_1 = V \\ p_4 = 0 \\ e_4 \leq 0 \wedge \text{Open} \end{array} \right) \\
c_3 &= \left(\begin{array}{l} e_1 - e_2 = e_3 = e_4 = 0 \\ f_1 = f_2 = f_3 \\ e_1 = V \\ e_2 = R \cdot f_2 \\ p_4 = \frac{1}{L} \cdot f_4 \\ f_3 \geq f_4 \wedge \text{Closed} \end{array} \right) & c_4 &= \left(\begin{array}{l} e_2 = e_3 = e_4 = 0 \\ f_1 = f_2 = f_3 = 0 \\ e_1 = V \\ p_4 = \frac{1}{L} \cdot f_4 \\ f_4 \leq 0 \wedge \text{Open} \end{array} \right)
\end{aligned}$$

It is arguable, whether our constitutive hybrid process for a controlled junction, forms a good representation of a diode, because we do not expect a diode to dissipate energy during switching. Adapting the constitutive hybrid process of the diode, in such a way that no energy dissipation takes place, leads to a new definition of the re-initialization clauses d_4 and d_5 , which makes them coincide with d_3 and d_2 , respectively.

$$\begin{aligned}
d_4 = d_3 &= \left[\begin{array}{l} E'_1 = E'_2 = 0 \\ E'_3 = E'_4 = \frac{(p_4^+)^2 - (p_4^-)^2}{2 \cdot L} \leq 0 \\ p'_1 = p'_2 = 0 \\ p'_3 = p'_4 \\ q'_1 = q'_2 = q'_3 = q'_4 = 0 \end{array} \right] & d_5 = d_2 &= \left[\begin{array}{l} E'_1 = E'_2 = E'_3 = E'_4 = 0 \\ p'_1 = p'_2 = 0 \\ p'_3 = p'_4 \\ q'_1 = q'_2 = q'_3 = q'_4 = 0 \\ (p_4^+)^2 = (p_4^-)^2 \end{array} \right]
\end{aligned}$$

The analysis in the remainder of this subsection, is independent of the choice to model a diode as a dissipating element during discontinuities, or not.

Further study on the flow clauses, shows a peculiarity in the behavior of c_2 . Using calculation on derivatives, we obtain $e_4 = \dot{p}_4 = 0$. As it turns out, the only case where time progresses in c_2 , is when both the voltage over the diode, and the current through the diode are zero. Interestingly, the set of solutions of c_2 is a subset of the set of solutions of c_4 , indicating that the diode can be interpreted as both conducting and blocking.

Algebraic manipulation of the constitutive hybrid process, allows us to combine the flow clauses c_2 and c_4 , showing character of implicit switching more clearly. The complete derivation is outside

the scope of this report, but in it, we use the fact that all solutions from c_4 that start with $p_4 = 0$, are also solutions from c_2 . We obtain the following alternative description of the circuit.

$$\begin{aligned}
\text{Circuit} &\approx ((d_1 \wedge [f_3^- \geq f_4^-] \wedge [\text{Closed}^-]) \gg c_1 \\
&\oplus (d_3 \wedge [f_3^- \geq f_4^-] \wedge [\text{Closed}^-]) \gg c_3 \\
&\oplus (((d_1 \wedge p_4^+ = 0) \vee d_4) \wedge [f_3^- \geq f_4^-] \wedge [\text{Closed}^-]) \gg c_4 \\
&\oplus (d_1 \wedge [f_3^- \geq f_4^-] \wedge [\text{Open}^-]) \gg c_1 \\
&\oplus (d_4 \wedge [f_3^- \geq f_4^-] \wedge [\text{Open}^-]) \gg c_3 \\
&\oplus (d_1 \wedge [f_3^- \geq f_4^-] \wedge [\text{Open}^-]) \gg c_4 \\
&\oplus (d_3 \wedge [e_4^- \leq 0] \wedge [\text{Closed}^-]) \gg c_1 \\
&\oplus (d_2 \wedge [e_4^- \leq 0] \wedge [\text{Closed}^-]) \gg c_3 \\
&\oplus (((d_4 \wedge p_4^+ = 0) \vee d_5) \wedge [f_3^- \geq f_4^-] \wedge [\text{Closed}^-]) \gg c_4 \\
&\oplus (d_4 \wedge [e_4^- \leq 0] \wedge [\text{Open}^-]) \gg c_1 \\
&\oplus (d_5 \wedge [e_4^- \leq 0] \wedge [\text{Open}^-]) \gg c_3 \\
&\oplus (d_1 \wedge [e_4^- \leq 0] \wedge [\text{Open}^-]) \gg c_4) \\
&\blacktriangleright \text{Circuit}
\end{aligned}$$

From this description, it becomes clear that, when the switch is opened, this enforces that the diode starts conducting. If the current through the inductance is negative, the implicit switch from blocking to conducting, leads to an energy loss, such that after the discontinuity, the generalized momentum of the inductance, and the current through the inductance, are zero. This implicit switching, was also described, for example, in the work of [10]. In the next example, on Newton's cradle, we will study another occurrence of implicit switching.

5.4 Newton's cradle

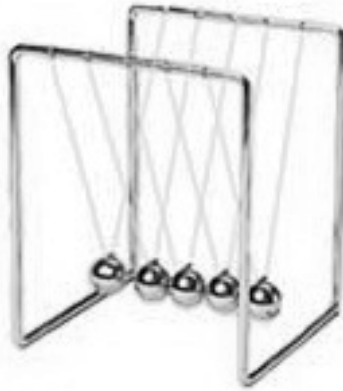

Figure 14: Newton's cradle

Newton's cradle, see figure 14, is a famous toy for physicists. It can be used to study conservation of momentum and energy in collisions. A standard way to model Newton's cradle, see for example [15], is to model the collision between two masses, and then study what happens if

multiple masses engage in these simple collisions interleavingly. As a result, there is a multiplicity of discontinuities when more than masses collide. When we model it using constitutive hybrid process, however, it turns out that these discontinuities are all collected, and executed as one single discontinuity.

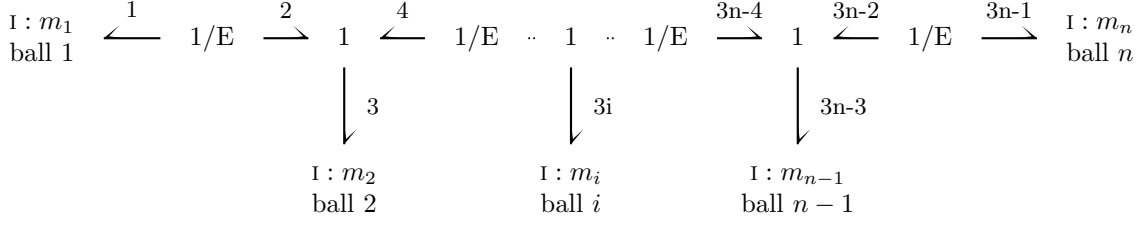

Figure 15: Bond graph model of Newton's cradle

In figure 15, we have depicted a bond graph model of Newton's cradle, for an arbitrary number of balls ($n > 2$). The switching conditions for the controlled junctions depend on the effort and flow of the colliding masses, as was the case for the simple collision of section 5.1. We find Act : $(q_{3i} = q_{3i+3} \wedge f_{3i} > f_{3i+3}) \vee (q_{3i} = q_{3i+3} \wedge f_{3i} = f_{3i+3} \wedge \frac{1}{m_i} \cdot e_{3i+1} \geq \frac{1}{m_{i+1}} \cdot e_{3i+2})$ and Inact : $(q_{3i} \leq q_{3i+3})$ for the collision between mass i and $i + 1$, with $1 < i < n$. Similar conditions apply if $i = 1$ or $i = n$, but the numbering is slightly different for these border cases. The constitutive hybrid process, for the case where we have three balls, is given below. We have assumed there, that all balls have the same mass m .

$$\begin{aligned}
\text{Cradle} &\approx ((A12 \wedge A45 \wedge d_{aa}) \gg c_{aa} \oplus (A12 \wedge A45 \wedge d_{as}) \gg c_{ai} \\
&\oplus (A12 \wedge A45 \wedge d_{sa}) \gg c_{ia} \oplus (A12 \wedge A45 \wedge d_{ss}) \gg c_{ii} \\
&\oplus (A12 \wedge I45 \wedge d_{as}) \gg c_{aa} \oplus (A12 \wedge I45 \wedge d_{ai}) \gg c_{ai} \\
&\oplus (A12 \wedge I45 \wedge d_{ss}) \gg c_{ia} \oplus (A12 \wedge I45 \wedge d_{si}) \gg c_{ii} \\
&\oplus (I12 \wedge A45 \wedge d_{sa}) \gg c_{aa} \oplus (I12 \wedge A45 \wedge d_{ss}) \gg c_{ai} \\
&\oplus (I12 \wedge A45 \wedge d_{ia}) \gg c_{ia} \oplus (I12 \wedge A45 \wedge d_{is}) \gg c_{ii} \\
&\oplus (I12 \wedge I45 \wedge d_{ss}) \gg c_{aa} \oplus (I12 \wedge I45 \wedge d_{si}) \gg c_{ai} \\
&\oplus (I12 \wedge I45 \wedge d_{is}) \gg c_{ia} \oplus (I12 \wedge I45 \wedge d_{ii}) \gg c_{ii}) \\
&\blacktriangleright \text{Cradle}
\end{aligned}$$

In this process definition, we used the following definitions for the clauses. Note, that especially in the flow-clauses, it was possible to simplify the switching conditions considerably.

$$\begin{aligned}
A12 &= \left[(q_1^- = q_3^- \wedge f_1^- > f_3^-) \vee (q_1^- = q_3^- \wedge f_1^- = f_3^- \wedge e_1^- \geq e_2^-) \right] \\
A45 &= \left[(q_3^- = q_5^- \wedge f_3^- > f_5^-) \vee (q_3^- = q_5^- \wedge f_3^- = f_5^- \wedge e_4^- \geq e_5^-) \right] \\
I12 &= \left[q_1^- \leq q_3^- \right] \\
I45 &= \left[q_3^- \leq q_5^- \right]
\end{aligned}$$

$$\begin{aligned}
d_{aa} &= \left[\begin{array}{l} E'_1 = \frac{(p_1^+)^2 - (p_1^-)^2}{2 \cdot m} \\ E'_3 = \frac{(p_3^+)^2 - (p_3^-)^2}{2 \cdot m} \\ E'_5 = \frac{(p_5^+)^2 - (p_5^-)^2}{2 \cdot m} \\ E'_1 + E'_3 + E'_5 = 0 \\ E'_1 = -E'_2 \\ E'_4 = -E'_5 \\ p'_1 + p'_3 + p'_5 = 0 \\ p'_1 = -p'_2 \\ p'_4 = -p'_5 \\ q'_1 = q'_2 = q'_3 = q'_4 = q'_5 = 0 \end{array} \right] \\
d_{sa} &= \left[\begin{array}{l} E'_1 = \frac{(p_1^+)^2 - (p_1^-)^2}{2 \cdot m} \\ E'_3 = \frac{(p_3^+)^2 - (p_3^-)^2}{2 \cdot m} \\ E'_5 = \frac{(p_5^+)^2 - (p_5^-)^2}{2 \cdot m} \\ E'_1 + E'_3 + E'_5 \leq 0 \\ E'_2 = E'_3 + E'_5 \\ E'_4 = -E'_5 \\ p'_1 + p'_3 + p'_5 = 0 \\ p'_1 = -p'_2 \\ p'_4 = -p'_5 \\ q'_1 = q'_2 = q'_3 = q'_4 = q'_5 = 0 \end{array} \right] \\
d_{ai} &= \left[\begin{array}{l} E'_1 = \frac{(p_1^+)^2 - (p_1^-)^2}{2 \cdot m} \\ E'_3 = \frac{(p_3^+)^2 - (p_3^-)^2}{2 \cdot m} \\ E'_1 + E'_3 = E'_4 = E'_5 = 0 \\ E'_1 = -E'_2 \\ p'_1 + p'_3 = p'_4 = p'_5 = 0 \\ p'_1 = -p'_2 \\ q'_1 = q'_2 = q'_3 = q'_4 = q'_5 = 0 \end{array} \right] \\
d_{ia} &= \left[\begin{array}{l} E'_3 = \frac{(p_3^+)^2 - (p_3^-)^2}{2 \cdot m} \\ E'_5 = \frac{(p_5^+)^2 - (p_5^-)^2}{2 \cdot m} \\ E'_1 = E'_2 = E'_3 + E'_5 = 0 \\ E'_4 = -E'_5 \\ p'_1 = p'_2 = p'_3 + p'_5 = 0 \\ p'_4 = -p'_5 \\ q'_1 = q'_2 = q'_3 = q'_4 = q'_5 = 0 \end{array} \right] \\
d_{ii} &= \left[\begin{array}{l} E'_1 = E'_2 = E'_3 = E'_4 = E'_5 = 0 \\ p'_1 = p'_2 = p'_3 = p'_4 = p'_5 = 0 \\ q'_1 = q'_2 = q'_3 = q'_4 = q'_5 = 0 \end{array} \right] \\
d_{as} &= \left[\begin{array}{l} E'_1 = \frac{(p_1^+)^2 - (p_1^-)^2}{2 \cdot m} \\ E'_3 = \frac{(p_3^+)^2 - (p_3^-)^2}{2 \cdot m} \\ E'_5 = \frac{(p_5^+)^2 - (p_5^-)^2}{2 \cdot m} \\ E'_1 + E'_3 + E'_5 \leq 0 \\ E'_1 = -E'_2 \\ E'_1 + E'_3 = E'_4 \\ p'_1 + p'_3 + p'_5 = 0 \\ p'_1 = -p'_2 \\ p'_4 = -p'_5 \\ q'_1 = q'_2 = q'_3 = q'_4 = q'_5 = 0 \end{array} \right] \\
d_{ss} &= \left[\begin{array}{l} E'_1 = \frac{(p_1^+)^2 - (p_1^-)^2}{2 \cdot m} \\ E'_3 = \frac{(p_3^+)^2 - (p_3^-)^2}{2 \cdot m} \\ E'_5 = \frac{(p_5^+)^2 - (p_5^-)^2}{2 \cdot m} \\ E'_1 + E'_3 + E'_5 \leq 0 \\ E'_2 = E'_3 - E'_4 \leq -E'_1 \\ E'_4 \leq -E'_5 \\ p'_1 + p'_3 + p'_5 = 0 \\ p'_1 = -p'_2 \\ p'_4 = -p'_5 \\ q'_1 = q'_2 = q'_3 = q'_4 = q'_5 = 0 \end{array} \right] \\
d_{si} &= \left[\begin{array}{l} E'_1 = \frac{(p_1^+)^2 - (p_1^-)^2}{2 \cdot m} \\ E'_3 = \frac{(p_3^+)^2 - (p_3^-)^2}{2 \cdot m} \\ E'_1 + E'_3 \leq E'_4 = E'_5 = 0 \\ E'_2 = E'_3 \\ p'_1 + p'_3 = p'_4 = p'_5 = 0 \\ p'_2 = p'_3 \\ q'_1 = q'_2 = q'_3 = q'_4 = q'_5 = 0 \end{array} \right] \\
d_{is} &= \left[\begin{array}{l} E'_3 = \frac{(p_3^+)^2 - (p_3^-)^2}{2 \cdot m} \\ E'_5 = \frac{(p_5^+)^2 - (p_5^-)^2}{2 \cdot m} \\ E'_3 + E'_5 \leq E'_1 = E'_2 = 0 \\ E'_3 = E'_4 \\ p'_3 + p'_5 \leq p'_1 = p'_2 = 0 \\ p'_3 = p'_4 \\ q'_1 = q'_2 = q'_3 = q'_4 = q'_5 = 0 \end{array} \right]
\end{aligned}$$

$$\begin{aligned}
c_{aa} &= \left(\begin{array}{l} f_1 = \frac{1}{m} \cdot p_1 \\ f_3 = \frac{1}{m} \cdot p_3 \\ f_5 = \frac{1}{m} \cdot p_5 \\ e_1 = e_2 = e_3 = e_4 = e_5 = 0 \\ f_1 = f_2 = f_3 = f_4 = f_5 \\ q_1 = q_3 = q_5 \end{array} \right) \\
c_{ai} &= \left(\begin{array}{l} f_1 = \frac{1}{m} \cdot p_1 \\ f_3 = \frac{1}{m} \cdot p_3 \\ f_5 = \frac{1}{m} \cdot p_5 \\ e_1 = e_2 = e_3 = e_4 = e_5 = 0 \\ f_1 = f_2 = f_3 = f_4 \\ q_1 = q_3 \leq q_5 \end{array} \right) \\
c_{ia} &= \left(\begin{array}{l} f_1 = \frac{1}{m} \cdot p_1 \\ f_3 = \frac{1}{m} \cdot p_3 \\ f_5 = \frac{1}{m} \cdot p_5 \\ e_1 = e_2 = e_3 = e_4 = e_5 = 0 \\ f_2 = f_3 = f_4 = f_5 \\ q_1 \leq q_3 = q_5 \end{array} \right) \\
c_{ii} &= \left(\begin{array}{l} f_1 = \frac{1}{m} \cdot p_1 \\ f_3 = \frac{1}{m} \cdot p_3 \\ f_5 = \frac{1}{m} \cdot p_5 \\ e_1 = e_2 = e_3 = e_4 = e_5 = 0 \\ f_2 = f_3 = f_4 \\ q_1 \leq q_3 \leq q_5 \end{array} \right)
\end{aligned}$$

To simplify the above presentation, we abstract from the variables associated with bonds 2 and 4. As explained before, this cannot be done formally in HyPA yet. However, our intuition on elimination of variables is such, that we expect to find that the the switching conditions for the re-initialization clauses can be simplified, because the flow conditions are such that $e_1 = e_2 = e_3 = e_4 = e_5 = 0$, except initially. We find:

$$\begin{aligned} A12 &= \left[q_1^- = q_3^- \wedge f_1^- \geq f_3^- \right] \\ A45 &= \left[q_3^- = q_5^- \wedge f_3^- \geq f_5^- \right] \\ I12 &= \left[q_1^- \leq q_3^- \right] \\ I45 &= \left[q_3^- \leq q_5^- \right] \end{aligned}$$

Furthermore, for the other clauses we obtain

$$\begin{aligned} d_{aa} &= \left[\begin{array}{l} E'_1 = \frac{(p_1^+)^2 - (p_1^-)^2}{2 \cdot m} \\ E'_3 = \frac{(p_3^+)^2 - (p_3^-)^2}{2 \cdot m} \\ E'_5 = \frac{(p_5^+)^2 - (p_5^-)^2}{2 \cdot m} \\ E'_1 + E'_3 + E'_5 = 0 \\ p'_1 + p'_3 + p'_5 = 0 \\ q'_1 = q'_3 = q'_5 = 0 \end{array} \right] & d_{as} &= \left[\begin{array}{l} E'_1 = \frac{(p_1^+)^2 - (p_1^-)^2}{2 \cdot m} \\ E'_3 = \frac{(p_3^+)^2 - (p_3^-)^2}{2 \cdot m} \\ E'_5 = \frac{(p_5^+)^2 - (p_5^-)^2}{2 \cdot m} \\ E'_1 + E'_3 + E'_5 \leq 0 \\ p'_1 + p'_3 + p'_5 = 0 \\ q'_1 = q'_3 = q'_5 = 0 \end{array} \right] \\ d_{sa} &= \left[\begin{array}{l} E'_1 = \frac{(p_1^+)^2 - (p_1^-)^2}{2 \cdot m} \\ E'_3 = \frac{(p_3^+)^2 - (p_3^-)^2}{2 \cdot m} \\ E'_5 = \frac{(p_5^+)^2 - (p_5^-)^2}{2 \cdot m} \\ E'_1 + E'_3 + E'_5 \leq 0 \\ p'_1 + p'_3 + p'_5 = 0 \\ q'_1 = q'_3 = q'_5 = 0 \end{array} \right] & d_{ss} &= \left[\begin{array}{l} E'_1 = \frac{(p_1^+)^2 - (p_1^-)^2}{2 \cdot m} \\ E'_3 = \frac{(p_3^+)^2 - (p_3^-)^2}{2 \cdot m} \\ E'_5 = \frac{(p_5^+)^2 - (p_5^-)^2}{2 \cdot m} \\ E'_1 + E'_3 + E'_5 \leq 0 \\ p'_1 + p'_3 + p'_5 = 0 \\ q'_1 = q'_3 = q'_5 = 0 \end{array} \right] \\ d_{ai} &= \left[\begin{array}{l} E'_1 = \frac{(p_1^+)^2 - (p_1^-)^2}{2 \cdot m} \\ E'_3 = \frac{(p_3^+)^2 - (p_3^-)^2}{2 \cdot m} \\ E'_1 + E'_3 = E'_5 = 0 \\ p'_1 + p'_3 = p'_5 = 0 \\ q'_1 = q'_3 = q'_5 = 0 \end{array} \right] & d_{si} &= \left[\begin{array}{l} E'_1 = \frac{(p_1^+)^2 - (p_1^-)^2}{2 \cdot m} \\ E'_3 = \frac{(p_3^+)^2 - (p_3^-)^2}{2 \cdot m} \\ E'_1 + E'_3 \leq E'_5 = 0 \\ p'_1 + p'_3 = p'_5 = 0 \\ q'_1 = q'_3 = q'_5 = 0 \end{array} \right] \\ d_{ia} &= \left[\begin{array}{l} E'_3 = \frac{(p_3^+)^2 - (p_3^-)^2}{2 \cdot m} \\ E'_5 = \frac{(p_5^+)^2 - (p_5^-)^2}{2 \cdot m} \\ E'_1 = E'_3 + E'_5 = 0 \\ p'_1 = p'_3 + p'_5 = 0 \\ q'_1 = q'_3 = q'_5 = 0 \end{array} \right] & d_{is} &= \left[\begin{array}{l} E'_3 = \frac{(p_3^+)^2 - (p_3^-)^2}{2 \cdot m} \\ E'_5 = \frac{(p_5^+)^2 - (p_5^-)^2}{2 \cdot m} \\ E'_3 + E'_5 \leq E'_1 = 0 \\ p'_3 + p'_5 \leq p'_1 = 0 \\ q'_1 = q'_3 = q'_5 = 0 \end{array} \right] \\ d_{ii} &= \left[\begin{array}{l} E'_1 = E'_3 = E'_5 = 0 \\ p'_1 = p'_3 = p'_5 = 0 \\ q'_1 = q'_3 = q'_5 = 0 \end{array} \right] \end{aligned}$$

$$\begin{aligned} c_{aa} &= \left(\begin{array}{l} f_1 = \frac{1}{n} \cdot p_1 \\ f_3 = \frac{1}{n} \cdot p_3 \\ f_5 = \frac{1}{m} \cdot p_5 \\ e_1 = e_3 = e_5 = 0 \\ f_1 = f_3 = f_5 \\ q_1 = q_3 = q_5 \end{array} \right) & c_{ai} &= \left(\begin{array}{l} f_1 = \frac{1}{n} \cdot p_1 \\ f_3 = \frac{1}{n} \cdot p_3 \\ f_5 = \frac{1}{m} \cdot p_5 \\ e_1 = e_3 = e_5 = 0 \\ f_1 = f_3 \\ q_1 = q_3 \leq q_5 \end{array} \right) \\ c_{ia} &= \left(\begin{array}{l} f_1 = \frac{1}{n} \cdot p_1 \\ f_3 = \frac{1}{n} \cdot p_3 \\ f_5 = \frac{1}{m} \cdot p_5 \\ e_1 = e_3 = e_5 = 0 \\ f_3 = f_5 \\ q_1 \leq q_3 = q_5 \end{array} \right) & c_{ii} &= \left(\begin{array}{l} f_1 = \frac{1}{n} \cdot p_1 \\ f_3 = \frac{1}{n} \cdot p_3 \\ f_5 = \frac{1}{m} \cdot p_5 \\ e_1 = e_3 = e_5 = 0 \\ q_1 \leq q_3 \leq q_5 \end{array} \right) \end{aligned}$$

To illustrate the way in which multiple discontinuities are collected into one single discontinuity, we study the case where, initially, all balls have the same position, and the most left ball has a velocity in the direction of the others. We discuss the completely elastic, as well as the completely inelastic collision of the balls.

If the balls collide completely elastically, the first ball will transfer its momentum to the second, and the second will transfer it to the third. Internally, there seem to be two discontinuities involved. However, the ultimate solution is that the first ball comes to a stand still, while the third ball flies off with the initial velocity of the first. It is not hard to verify, that this is indeed one of the possible solutions of the subprocess $(I12 \wedge A45 \wedge d_{ss}) \gg c_{ai}$.

If the balls collide completely inelastically, the first ball gives half of its momentum to the second, which then has a higher velocity than the third, and thus shares its momentum with the third. After this, the first ball has a higher velocity than the second, and gives half of its momentum (a quarter of the initial momentum) to the second. This continues ad infinitum, but the sequence of events converges to the situation where all balls have one third of the original velocity. This convergence point, indeed, is one of the possible solutions of the subprocess $(I12 \wedge A45 \wedge d_{sa}) \gg c_{aa}$.

5.5 Vacuum chambers at ASML

As an example of a model from the domain of flow-dynamics, we briefly study a model of a vacuum chamber, as it is used in a wafer-stepper produced by ASML. The vacuum chamber, sketched in figure 16 has two sluices that provide access to the outside world. Through one sluice, wafers enter the chamber, while through the other sluice, the finished wafers leave the chamber. One of the requirements of the system, naturally, is to schedule the entering and leaving of the wafers in such a way that the air pressure in the vacuum chamber remains low.

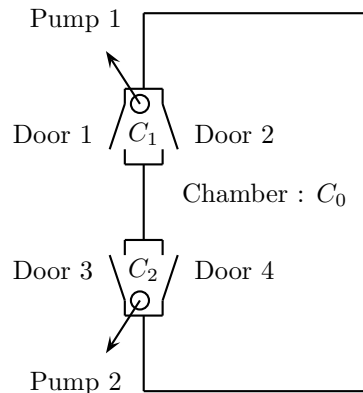

Figure 16: Schematic model of the vacuum chamber

A bond graph model of this system is depicted in figure 17. The predicates $A1, A2, A3, A4, I1, I2, I3$ and $I4$ where used to model the conditions under which the sluices open and close. Furthermore, we have assumed that $I_i \Rightarrow \neg A_i$. The continuous constitutive relation for the pumps that we used is $R(e) = R \cdot e$ for $e \geq 0$ and $R(e) = 0$ for $e \leq 0$. Naturally, such a pump can also be modeled using a linear resistor and a $1/F$ -junction, although the discontinuous behavior may then be subtly different.

The associated hybrid constitutive process is too complex to show in this report. However,

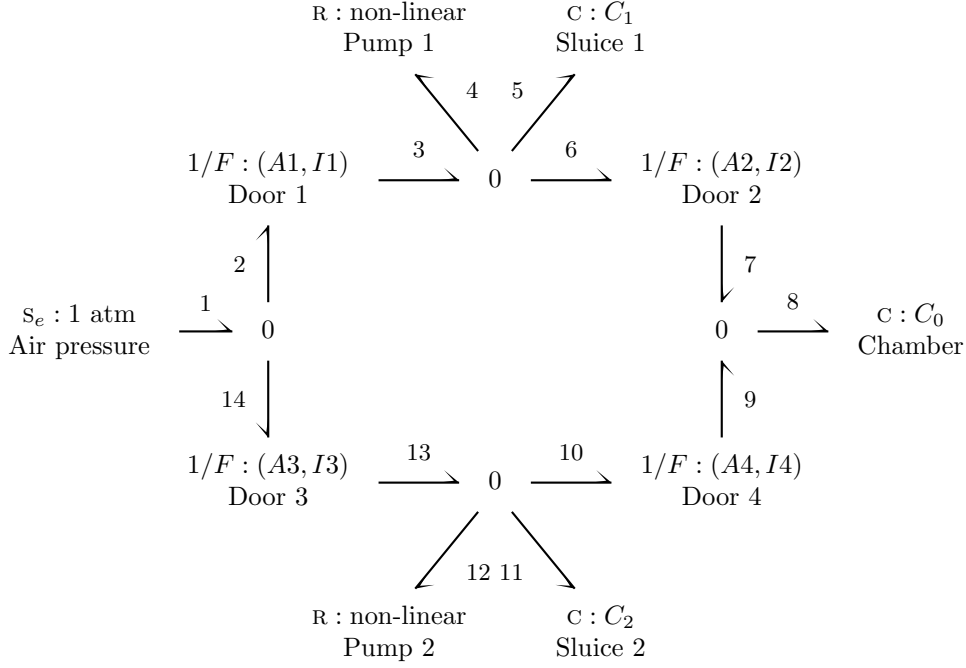

Figure 17: Bond graph model for vacuum chamber

using the bond graph alone, we can already explain some of the insights it gives us about the system.

For example, the objective of the vacuum chamber, is to guarantee that the pressure in the chamber stays below a certain threshold $P_{max} < 1$ atm. Obviously, the outside and inside door of one sluice should not be open at the same time, since there would be a connection between the chamber and the outside air. But, studying the bond graph, we also find that it is unsafe to simultaneously close the inner door and open the outer door. The bond graph indicates that even then, there is a temporary connection. We conclude, that we have to control the vacuum chamber in such a way that, in certain situations, only one door is opened, or closed, at the same time. For simplicity, we assume this in all situations. The, still complex, switching behavior of the controller, is then expressed by the following process:

$$\begin{aligned}
\text{Controller} \approx & \left(\left[\begin{array}{c} I1^- \wedge I2^- \\ I3^- \wedge I4^- \end{array} \right] \gg \left[\begin{array}{c} I1 \wedge I2 \\ I3 \wedge I4 \end{array} \right] \oplus \left[\begin{array}{c} I1^- \wedge I2^- \\ I3^- \wedge I4^- \end{array} \right] \gg \left[\begin{array}{c} A1 \wedge I2 \\ I3 \wedge I4 \end{array} \right] \right. \\
& \oplus \left[\begin{array}{c} I1^- \wedge I2^- \\ I3^- \wedge I4^- \end{array} \right] \gg \left[\begin{array}{c} I1 \wedge A2 \\ I3 \wedge I4 \end{array} \right] \oplus \left[\begin{array}{c} I1^- \wedge I2^- \\ I3^- \wedge I4^- \end{array} \right] \gg \left[\begin{array}{c} I1 \wedge I2 \\ A3 \wedge I4 \end{array} \right] \\
& \oplus \left[\begin{array}{c} I1^- \wedge I2^- \\ I3^- \wedge I4^- \end{array} \right] \gg \left[\begin{array}{c} I1 \wedge I2 \\ I3 \wedge A4 \end{array} \right] \oplus \left[\begin{array}{c} A1^- \wedge I2^- \\ I3^- \wedge I4^- \end{array} \right] \gg \left[\begin{array}{c} A1 \wedge I2 \\ I3 \wedge I4 \end{array} \right] \\
& \oplus \left[\begin{array}{c} A1^- \wedge I2^- \\ I3^- \wedge I4^- \end{array} \right] \gg \left[\begin{array}{c} I1 \wedge I2 \\ I3 \wedge I4 \end{array} \right] \oplus \left[\begin{array}{c} A1^- \wedge I2^- \\ I3^- \wedge I4^- \end{array} \right] \gg \left[\begin{array}{c} A1 \wedge I2 \\ A3 \wedge I4 \end{array} \right] \\
& \oplus \left[\begin{array}{c} A1^- \wedge I2^- \\ I3^- \wedge I4^- \end{array} \right] \gg \left[\begin{array}{c} A1 \wedge I2 \\ I3 \wedge A4 \end{array} \right] \oplus \left[\begin{array}{c} I1^- \wedge A2^- \\ I3^- \wedge I4^- \end{array} \right] \gg \left[\begin{array}{c} I1 \wedge A2 \\ I3 \wedge I4 \end{array} \right] \\
& \oplus \left[\begin{array}{c} I1^- \wedge A2^- \\ I3^- \wedge I4^- \end{array} \right] \gg \left[\begin{array}{c} I1 \wedge I2 \\ I3 \wedge I4 \end{array} \right] \oplus \left[\begin{array}{c} I1^- \wedge A2^- \\ I3^- \wedge I4^- \end{array} \right] \gg \left[\begin{array}{c} I1 \wedge A2 \\ A3 \wedge I4 \end{array} \right]
\end{aligned}$$

$$\begin{aligned}
& \oplus \left[\begin{array}{l} I1^- \wedge A2^- \\ I3^- \wedge I4^- \end{array} \right] \gg \left(\begin{array}{l} I1 \wedge A2 \\ I3 \wedge A4 \end{array} \right) \oplus \left[\begin{array}{l} I1^- \wedge I2^- \\ A3^- \wedge I4^- \end{array} \right] \gg \left(\begin{array}{l} I1 \wedge I2 \\ A3 \wedge I4 \end{array} \right) \\
& \oplus \left[\begin{array}{l} I1^- \wedge I2^- \\ A3^- \wedge I4^- \end{array} \right] \gg \left(\begin{array}{l} I1 \wedge I2 \\ I3 \wedge I4 \end{array} \right) \oplus \left[\begin{array}{l} I1^- \wedge I2^- \\ A3^- \wedge I4^- \end{array} \right] \gg \left(\begin{array}{l} A1 \wedge I2 \\ I3 \wedge I4 \end{array} \right) \\
& \oplus \left[\begin{array}{l} I1^- \wedge I2^- \\ A3^- \wedge I4^- \end{array} \right] \gg \left(\begin{array}{l} I1 \wedge A2 \\ A3 \wedge I4 \end{array} \right) \oplus \left[\begin{array}{l} I1^- \wedge I2^- \\ I3^- \wedge A4^- \end{array} \right] \gg \left(\begin{array}{l} I1 \wedge I2 \\ I3 \wedge A4 \end{array} \right) \\
& \oplus \left[\begin{array}{l} I1^- \wedge I2^- \\ I3^- \wedge A4^- \end{array} \right] \gg \left(\begin{array}{l} I1 \wedge I2 \\ I3 \wedge I4 \end{array} \right) \oplus \left[\begin{array}{l} I1^- \wedge I2^- \\ I3^- \wedge A4^- \end{array} \right] \gg \left(\begin{array}{l} A1 \wedge I2 \\ I3 \wedge A4 \end{array} \right) \\
& \oplus \left[\begin{array}{l} I1^- \wedge I2^- \\ I3^- \wedge A4^- \end{array} \right] \gg \left(\begin{array}{l} I1 \wedge A2 \\ I3 \wedge A4 \end{array} \right) \oplus \left[\begin{array}{l} A1^- \wedge I2^- \\ A3^- \wedge I4^- \end{array} \right] \gg \left(\begin{array}{l} A1 \wedge I2 \\ A3 \wedge I4 \end{array} \right) \\
& \oplus \left[\begin{array}{l} A1^- \wedge I2^- \\ A3^- \wedge I4^- \end{array} \right] \gg \left(\begin{array}{l} I1 \wedge I2 \\ A3 \wedge I4 \end{array} \right) \oplus \left[\begin{array}{l} A1^- \wedge I2^- \\ A3^- \wedge I4^- \end{array} \right] \gg \left(\begin{array}{l} A1 \wedge I2 \\ I3 \wedge I4 \end{array} \right) \\
& \oplus \left[\begin{array}{l} I1^- \wedge A2^- \\ A3^- \wedge I4^- \end{array} \right] \gg \left(\begin{array}{l} I1 \wedge A2 \\ A3 \wedge I4 \end{array} \right) \oplus \left[\begin{array}{l} I1^- \wedge A2^- \\ A3^- \wedge I4^- \end{array} \right] \gg \left(\begin{array}{l} I1 \wedge I2 \\ A3 \wedge I4 \end{array} \right) \\
& \oplus \left[\begin{array}{l} I1^- \wedge A2^- \\ A3^- \wedge I4^- \end{array} \right] \gg \left(\begin{array}{l} I1 \wedge A2 \\ I3 \wedge I4 \end{array} \right) \oplus \left[\begin{array}{l} A1^- \wedge I2^- \\ I3^- \wedge A4^- \end{array} \right] \gg \left(\begin{array}{l} A1 \wedge I2 \\ I3 \wedge A4 \end{array} \right) \\
& \oplus \left[\begin{array}{l} A1^- \wedge I2^- \\ I3^- \wedge A4^- \end{array} \right] \gg \left(\begin{array}{l} I1 \wedge I2 \\ I3 \wedge A4 \end{array} \right) \oplus \left[\begin{array}{l} A1^- \wedge I2^- \\ I3^- \wedge A4^- \end{array} \right] \gg \left(\begin{array}{l} A1 \wedge I2 \\ I3 \wedge I4 \end{array} \right) \\
& \oplus \left[\begin{array}{l} I1^- \wedge A2^- \\ I3^- \wedge A4^- \end{array} \right] \gg \left(\begin{array}{l} I1 \wedge A2 \\ I3 \wedge A4 \end{array} \right) \oplus \left[\begin{array}{l} I1^- \wedge A2^- \\ I3^- \wedge A4^- \end{array} \right] \gg \left(\begin{array}{l} I1 \wedge I2 \\ I3 \wedge A4 \end{array} \right) \\
& \oplus \left[\begin{array}{l} I1^- \wedge A2^- \\ I3^- \wedge A4^- \end{array} \right] \gg \left(\begin{array}{l} I1 \wedge A2 \\ I3 \wedge I4 \end{array} \right) \blacktriangleright \text{Controller}
\end{aligned}$$

We have to add that the inner doors should not open if the pressure in the sluice is too high. We find the following constraints on the conditions $A2$ and $A4$:

$$\begin{aligned}
A2 & \Rightarrow \left[\frac{C_1 \cdot e_5 + C_0 \cdot e_8}{C_1 + C_0} \leq P_{max} \right] \\
A4 & \Rightarrow \left[\frac{C_2 \cdot e_{11} + C_0 \cdot e_8}{C_2 + C_0} \leq P_{max} \right].
\end{aligned}$$

Note, that these constraints may become more complex, if we allow simultaneous opening of the inside doors of the sluices.

We conjecture, that together, these requirements lead to a safe switching structure for the vacuum chamber. This switching structure can serve as a specification for a controller that is to be implemented in either a physical, computational or hybrid way. The proof that the switching structure is indeed safe, as well as the design of the actual controller, are outside the scope of this report. Safety of the controller could, for example, be proven using the techniques described in [5]. However, before engaging in such proofs, it is desirable to first develop some tool support for the manipulation of HyPA process descriptions.

6 Conclusions

When modeling a physical system, it is common practice to describe the components that constitute the system, using so-called constitutive relations on the physical variables that play a role in the system. In this report, we have described a method to find a hybrid process algebraic description of these constitutive relations, in case the physical system contains discontinuities as a result of abstraction from small time-scale behavior. As a vehicle towards these so-called constitutive hybrid process descriptions, we assumed a hybrid bond graph model of the physical system under

study. For every bond graph element, a constitutive hybrid process was derived, based on the possible behaviors of the continuous constitutive equations for that element. The parallel composition of the processes associated with the separate elements, leads to an algebraic description of the system as a whole. An alternative look at our work, is that we have developed a process algebraic semantics to hybrid bond graphs.

We have shown the construction of constitutive hybrid processes, for several examples, in which collision of mechanical objects, the behavior of electrical switches and diodes, and the behavior of sluices and pumps played an important role. Analysis of these constitutive processes, amongst others, has clarified the consequences of implicit switching and of the behavior of consecutive discontinuities in a bond graph model.

Perhaps the most interesting observation in the construction of constitutive processes for bond graph elements, is that a change in connection structure, may lead to a dissipation of energy. The exact energy loss is not specified for the controlled junctions and switch elements, which sometimes results in a model with branching behavior. For example, this is the case in our collision model, where the elasticity of impact is undetermined. We argued that this kind of branching is reasonable, since it allows the modeler to reason about processes of which not all parameters are known. If elasticity of the impact were known, the collision dynamics could have been modeled explicitly, leading to a more detailed model, in which switching does occur between collision and free movement of the masses, but no discontinuous behavior takes place. Sometimes, more detailed models are even necessary. For example, if the influence of external forces on a collision cannot be neglected.

In the analysis of hybrid bond graphs, it turned out to be convenient to be able to eliminate variables that are associated with bonds between junctions, from a constitutive hybrid process. Also, in some cases, it would be appropriate to eliminate variables associated with certain source elements. In this report, we have treated the elimination of variables informally, because, at the moment, we do not have a formal treatment of such eliminations in HyPA. However, work on an elimination operator that is fit for the task is currently being carried out, and we have a fairly good idea of how to develop it, because a similar kind of abstraction is already available, in part, for the hybrid χ language [13].

In section 4.6, we mentioned that, for standard bond graph theory, there is a set of graph reduction rules, that lead to equivalent bond graphs, modulo elimination of variables associated with connections between junctions [3]. Based on what we already know about a possible elimination operator, we conjecture, that those rules are still valid for the hybrid case, with the exception of special elements, like resistors of value 0, and infinite resistances, inductances and capacitances. These elements need special treatment due to the observations made at the end of section 2.3. Awaiting a formal treatment of elimination in HyPA, the development of new graph reduction rules for the hybrid case, is left as future work.

One important aspect of bond graph theory, namely the causality analysis of a bond graph, has not been touched in this report. Causality analysis is a useful tool when we want to simulate the behavior of a system. Amongst others, it allows the user to transform the constitutive relations into so-called ordinary differential equations, which are differential equations of the form $\dot{x} = f(x)$ and $y = g(x)$. The solutions of such equations are easier to approximate computationally than the solutions of the constitutive equations we discussed in this report. The basis of causality theory for bond graphs, lies in the assignment of an input or output status to the effort and flow variables in a graph. In hybrid bond graphs, a suitable distinction between input and output cannot always be made, because it can depend on the current connection structure which status is preferable for a certain variable. In HyPA, it should be possible to treat different connection structures, and the discontinuous behavior when switching between these structures, separately. We hope, therefore, that the constitutive hybrid process semantics that we have given in this report, can be helpful in the development of causality theory for hybrid bond graphs, and will lead to new insights in

possible ways to simulate and analyze hybrid systems.

Acknowledgements Many thanks go to Michel Reniers and Jan Friso Groote, for proof-reading preliminary versions of this report. We would also like to express our gratitude to Progress/STW (Grant EES5173), Philips CFT and Assembleon, for their financial and material support of our project on the development of hybrid systems theory.

References

- [1] P.C. Breedveld. The context-dependent trade-off between conceptual and computational complexity illustrated by the modeling and simulation of colliding objects. In P. Borne et al., editor, *Proceedings Computational Engineering in Systems Applications '96 (IMACS/IEEE-SMC Multiconference)*, pages 48–54, Lille, France, 1996.
- [2] P.C. Breedveld and J. van Amerongen. *Dynamische systemen: modelvorming en simulatie met bondgrafen*. Open Universiteit, Heerlen, Netherlands, 1994.
- [3] Hitech Consultants. <http://www.bondgraphs.com>.
- [4] P.J.L. Cuijpers and M.A. Reniers. Hybrid process algebra. *Journal of Logic and Algebraic Programming*. to appear.
- [5] P.J.L. Cuijpers and M.A. Reniers. Action and predicate safety of hybrid processes. Technical Report CSR 04-10, TU/e, Eindhoven, Netherlands, 2004.
- [6] J.H.J. Almering e.a. *Analyse*. Delftse Uitgevers Maatschappij B.V., 1993.
- [7] O. Heaviside. On the forces, stresses, and fluxes of energy in the electromagnetic field. *Philosophical Transaction of the Royal Society*, 1893.
- [8] D.C. Karnopp, D.L. Margolis, and R.C. Rosenberg. *System Dynamics: A Unified Approach*. John Wiley and Sons, Inc., 1990.
- [9] P. Mosterman, G. Biswas, and O. Otter. Simulation of discontinuities in physical system models based on conservation principles. In *Proceedings of the 1998 Summer Computer Simulation Conference*, Reno, Nevada, 1998.
- [10] P.J. Mosterman. *Hybrid Dynamic Systems: A Hybrid Bond Graph Modeling Paradigm and its Application in Diagnosis*. PhD thesis, Vanderbilt University, Nashville, Tennessee, 1997.
- [11] H.M. Paynter. *Analysis and Design of Engineering Systems*. M.I.T. Press, Cambridge, Massachusetts, 1961.
- [12] J.-E. Strömberg. *A mode switching modelling philosophy*. PhD thesis, Linköping, Sweden, 1994.
- [13] D.A. van Beek, N.G. Jansen, K.L. Man, M.A. Reniers, J.E. Rooda, and R.R.H. Schiffelers. Relating chi to hybrid automata. In S.Chick, P.J. Sánchez, D. Ferrin, and D.J. Morrice, editors, *Proceedings of the 2003 Winter Simulation Conference*, pages 632–640, New Orleans, USA, 2003.
- [14] P.P.J. van den Bosch and A.C. van der Klauw. *Modeling, Identification and Simulation of Dynamical Systems*. CRC Press, 1994.
- [15] A.J. van der Schaft and J.M. Schumacher. *An Introduction to Hybrid Dynamical Systems*, volume 251 of *Lecture Notes in Control and Information Sciences*. Springer-Verlag, London, 2000.