

to be submitted to Journal of Sound and Vibration

AEROACOUSTICS RESEARCH IN EUROPE: THE CEAS-ASC REPORT ON 2003 HIGHLIGHTS

W. SCHRÖDER

Chair of Fluid Mechanics and Institute of Aerodynamics, RWTH Aachen University,

Wüllnerstr. zw. 5 u. 7, 52062 Aachen, Germany

Fax. +49 241 8095410

E-mail: office@aia.rwth-aachen.de

This is a report on some highlights of aeroacoustics research in Europe in 2003, compiled from information provided to the Aeroacoustics Specialists Committee (ASC) of the Confederation of European Aerospace Societies (CEAS). The CEAS currently comprises the national Aerospace Societies of France (Association Aéronautique et Astronautique de France (AAAF)), Germany (Deutsche Gesellschaft für Luft- und Raumfahrt (DGLR)), Italy (Associazione Italiana di Aeronautica e Astronautica (AIDAA)), The Netherlands (Nederlandse Vereniging voor Luchtvaarttechniek (NVvL)), Spain (Asociación de Ingenieros Aeronáuticos de España (AIAE)), Sweden (Flygtekniska Föreningen (FTF)), Switzerland (Schweizerische Vereinigung für Flugwissenschaften (SVFW)) and the United Kingdom (The Royal Aeronautical Society (RAeS)).

1. INTRODUCTION

The CEAS Aeroacoustics Specialists Committee (ASC) supports and promotes the interests of the scientific and industrial aeroacoustics community on a European scale and European aeronautics activities internationally. In this context, “aeroacoustics” encompasses all aerospace acoustics and related areas. Each year the committee highlights some of the research and development projects in Europe. This paper summarises events in 2003.

During 2003 numerous research programmes, for instance FACE, ENABLE, ROSAS, TurboNoiseCFD, JEAN and DESIRE, were funded by the European Union. Some of the contributions submitted to the editor summarise selected findings from these programmes, while other articles cover issues supported by national associations. Furthermore, a concise summary of the workshop on “Aeroacoustics of Supersonic Transport” is included in this report. Enquiries concerning all contributions should be addressed to the authors who are given at the end of each subsection.

2. 7th CEAS ASC WORKSHOP

The 7th CEAS-ASC Workshop on “Aeroacoustics of Supersonic Transport”, supported by the X2-NOISE Thematic Network of the European Commission as its 2nd Technical Workshop, was held on 13-14 November 2003 in Prague (Czech Technical University, Prof. Ondrej Jiricek). It included two main subjects : 1) Takeoff Silencing and 2) Sonic Boom Mitigation.

In his keynote lecture, J. Julliard (Snecma) focused on Mid Tandem Fan (MTF) and Mixer-Ejector powerplants and presented experimental results corresponding rather to Stage 3 than to future ICAO regulations. For the MTF, he pointed out the unexpected difficulty to limit midfan noise to acceptable levels.

Several ways of reducing jet noise were presented and discussed. Noise reduction for a given jet velocity could be obtained by specific shapes of the nozzle lips. V. Kopiev (TsAGI) performed a detailed mode analysis of circular supersonic jets. Strong interactions of modes from corrugated nozzles could be of interest for noise reduction. An alternative idea of a nozzle equipped with chevrons made of shape memory alloys was presented by V. Baklanov (Tupolev).

G. Fournier (GFIC) and J. Whurr (Rolls-Royce) agreed on concluding that ejectors are practically too heavy for participating in any economical propulsion means. This conclusion is not really conflicting with Japanese programmes for a higher cruise Mach number (not reported). In this ambitious project, already designed but not yet demonstrated, the objective is an ejector weight less than 1/10 of the engine weight. G. Fournier suggested an economical condition for having retractable high-BPR (bypass ratio) boost turbofans supplementing fixed low-BPR means used at a lower power setting for takeoff. The weight of the system for moving and storing the high-BPR means should be less than ½ of their own weight (objective of Mach 2 cruise). J. Whurr preferred lower cruise Mach numbers (~1.6) to recommend turbofans with a hot core determined for supersonic cruise and a fan diameter tailored for noise regulations. The cycles in the various flight conditions are optimised with sophisticated nozzles. BPRs as high as 3 or 4 were proposed.

In addition to technical means, A. Mirzoyan (Sukhoi and CIAM) plans to obtain the required low noise level by optimised flight procedures at takeoff.

As the intensity of the sonic boom is mainly depending on aircraft weight, many participants are concerned with projects of supersonic business jets instead of big transports. Only A. Poukhov (Tupolev) gave a description of his Tu444 but his solutions for boom and noise reduction were not presented in detail.

Nobody reported on sonic boom reduction by shape tailoring (thickness effect) but G. Schouten investigated the lift component of sonic boom. He looks for redistributing the lift between upper and lower surfaces of the aircraft. Complete suppression of the downward shockwave is not required, but a reduction of the lift of the lower surfaces at the cost of increased drag could reduce the intensity of the downward shockwave, and might be of practical interest. L. Morino (Universita Roma 3) took into account viscosity and obtained a clear equation for assessing its moderate effect on noise propagation.

Most of the investigations reported by F. Coulouvrat (Université Pierre et Marie Curie) are also related with sonic boom development rather than its source control. Several of his theoretical predictions are supported by laboratory scale experiments. The various phenomena considered are significantly concerned by meteorological conditions. His practical conclusions aim at avoiding any “excess boom” rather than give recipes for sonic boom reduction.

The synthetic keynote lecture given by L. Maurice (FAA) included issues other than noise and sonic boom in order to evaluate the future perspectives of supersonic transport. She clearly suggested that supersonic airliners must achieve community noise, landing and takeoff and cruise emission levels not exceeding those of subsonic aircraft. She reminded the audience of the recent results from the DARPA-NASA Quiet Supersonic Platform programme : A sonic boom intensity reduction might permit people to accept overflight of light aircraft such as small supersonic business jets, the boom of which is already limited anyway, but such a relative reduction is of much less interest for a big transport generating a much larger boom. However, she reminded the audience that what constitutes an acceptable boom is not yet determined. The answer requires research on public acceptability.

The final discussion is reported in detail by L.M.B.C. Campos (IST) in the workshop proceedings. The moderator G. Readman (CAA/UK) tried to obtain some agreement from academia, industry and authority representatives on major issues. The current ICAO noise regulations (Annex 16, Volume 1, Chapter 3 and Chapter 4) for subsonic aircraft could be improved again in the future with respect to new noise level limits, to a possible giving up of the notion of cumulative margins and to new certification procedures. But there is a consensus that the rules should represent the same level of stringency for both supersonic and subsonic aircraft. On the question of supersonic flight over land,

there was a consensus that more research and experimentation is needed to establish the level of acceptability of sonic boom. Such an acceptance is likely to be less probable for big transports.

[By G. Fournier, GFIC, Chatenay-Malabry, France]

3. STRUCTURAL ACOUSTICS

3.1. ACTIVE STRUCTURAL ACOUSTIC CONTROL

In many cases, noise is produced by large shell like parts of a structure. The out-of-plane vibration of such structures couples to the acoustic medium, resulting in sound radiation. Passive sound absorption or reflection, e.g. by means of absorbing materials (glasswool) or noise shields, are usually effective at high frequencies. Active control methods seem to be an interesting solution for low frequency noise problems.

The goal of an active control system is to cancel the response generated by the disturbance by introducing one or several secondary controlled source(s). In active structural acoustic control actuators are directly attached to the structure, and a reduction of the radiated sound is obtained by changing the vibration of the structure. Furthermore, control systems are used with sensors that measure vibrations instead of acoustic pressure. Piezoelectric materials are often used in active structural acoustic control as actuator or sensor, mainly because they can be bonded directly to the structure.

The performance of an active structural acoustic control system strongly depends on the actuator and sensor locations. At the University Twente research is carried out on the optimisation of actuator and sensor locations such that the active control system reduces the sound radiation in the best possible way. Such an objective is evaluated using a finite element model, which includes piezoelectric patches, combined with a model to predict the radiated sound. A genetic algorithm is applied as the optimisation tool. An important advantage of this algorithm is that it is effective in finding the global minimum of an objective function with several local minima. The optimisation strategy was tested for a set-up consisting of a clamped rectangular plate with decentralised feedback control units, where each unit consisted of a piezoelectric actuator patch, accelerometer, and a direct velocity feedback loop. With the optimal set-up it is possible to significantly reduce the sound power radiated by the plate in the frequency range up to 500 Hz.

[By M.H.H. O. Nijhuis and A. de Boer, University of Twente, Enschede, The Netherlands]

3.2. OPTIMISED SOUND ABSORBING PANELS WITH QUARTER-WAVE RESONATORS

For modern aircraft, boundary layer induced noise is known to dominate cabin noise at cruise conditions. In order to improve the environmental comfort of the passengers with respect to this noise, the present research, which is part of the EU project FACE (Friendly Aircraft Cabin Environment), focuses on the optimisation of sound absorbing trim panels with quarter-wave resonators.

By varying the dimensions of the resonators different levels of sound absorption can be obtained in different frequency ranges. Optimisation of these resonator dimensions will result in a sound absorbing trim panel that optimally reduces the cabin noise in the dominant frequency range.

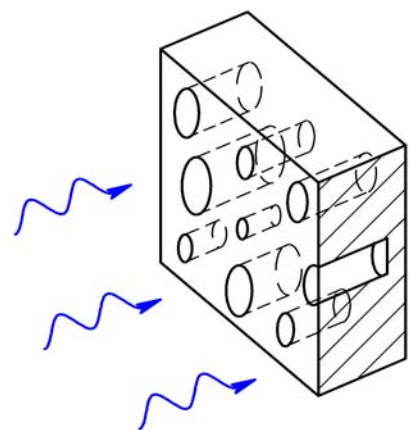

The so-called low reduced frequency model efficiently and accurately describes the viscothermal wave propagation of the air inside the resonators. Using this model, absorption coefficients can be calculated for different configurations. In order to be able to satisfy any desired absorption level within a specified frequency range, an optimisation algorithm has been implemented.

Results of optimisations in the frequency ranges of 500-1000 Hz and 1000-2000 Hz show that almost maximum absorption is obtained over the entire frequency ranges. Experimental validation of the numerically predicted optimal configurations is performed by means of impedance tube measurements.

Once the optimised configurations have been validated, a sound absorbing trim panel will be designed by tuning to a sound spectrum measured in a modern aircraft. In this way high absorption levels can be obtained for frequencies with high sound levels, whereas lower absorption levels are allowed for frequencies at which sound absorption is not necessary.

[By M.H.C. Hannink, Y.H. Wijnant and A. de Boer, University of Twente, Enschede, The Netherlands]

3.3. HYBRID PREDICTIVE METHODS FOR STRUCTURAL AND ACOUSTICS RESPONSES

The University of Naples (DPA) and Alenia/Aeronautics have participated in the recently finished European project Environmental Noise Associated with turbulent Boundary Layer Excitation (ENABLE), which has been part of the 5th framework program (G4RD-CT-2000-00223).

The research focuses on the analysis of the stochastic response of simple operators under the excitation of a given wall pressure distribution according to a turbulent boundary layer spectrum. The main activities performed by ALENIA and DPA can be classified in: (i) definition of exact and numerical responses for the structural vibration and the radiated acoustic power, (ii) analysis of the turbulent boundary layer models, (iii) analysis of the influence of the aeroelastic effect on the structural response, (iv) extension of the numerical procedure to more complicated structural operators.

The scaling procedure tested and applied during the ENABLE project allows to extend the use of the finite element method or any deterministic method to produce results at higher frequency ranges while keeping the computational costs constant [3.3.1, 3.3.2]. Furthermore, the simulation of the pressure distribution can be performed by applying the simplest scheme of the equivalent nodal area. That is, the cpu-time consuming evaluation of the integration, which is required for the cross correlation of the loads among any couple of finite elements or grid points, is avoided. All previous considerations hold for both the structural and the acoustic radiated power metrics [3.3.3]. The results obtained for both metrics in Figures 3.1 and 3.2 demonstrated that the procedure is able to cope with the turbulent boundary structural operators at a minimum computational effort.

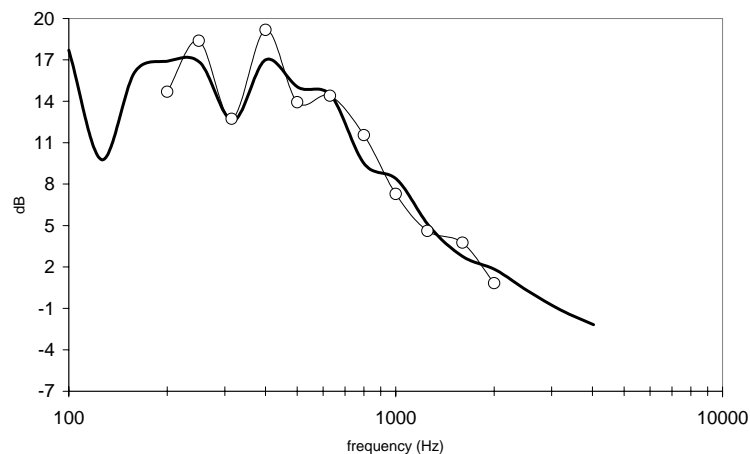

Figure 3.1: Structural metric: Thick line, exact response, $\eta=0.02$; circle, Scaled FEM, $\eta=0.02$

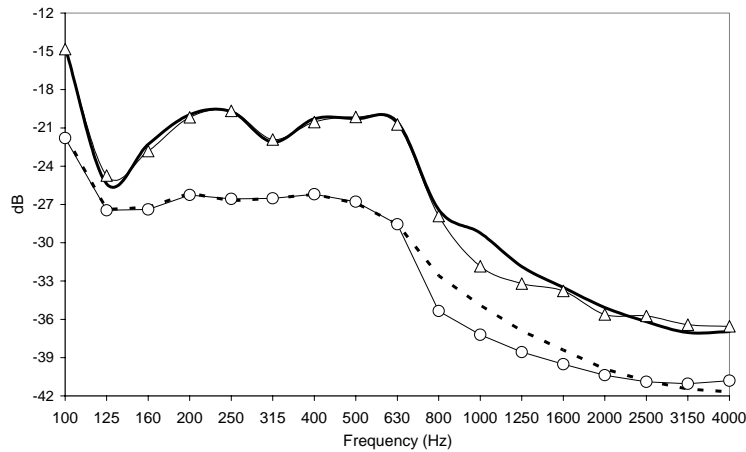

Figure 3.2: Power metric: Thick line, exact response, $\eta=0.02$; triangle, FEM and Scaled FEM, $\eta=0.02$; thick dashed line, exact response, $\eta=0.10$; circle, FEM and Scaled FEM, $\eta=0.10$

[By S. De Rosa, University of Naples, Naples, Italy]

4. ROTORCRAFT AND PROP/FAN NOISE

4.1. SILENT AIRCRAFT CONCEPTS

The general objective of the ROSAS project (Research on Silent Aircraft Concepts) is to develop the necessary capabilities for the evaluation and selection of innovative silent aircraft configurations. In order to validate and calibrate semi-empirical methods for the prediction of noise shielding effects, an experimental database is developed through the results of a comprehensive wind tunnel campaign in the ONERA CEPRA 19 anechoic facility (Figure 4.1). A new model support and rear fuselage with shielding empennage has been manufactured and adapted to the existing aircraft model used in the RAIN (Reduction of Airframe and Installation Noise) program. An existing model engine (TPS) has been used for the simulation of shielded fan noise and a new exhaust nozzle representing an advanced very high by-pass ratio engine has been designed and manufactured for jet noise simulation.

Several rear-fuselage and over-wing engine positions have been tested. The expected noise shielding is the most significant effect in the over-wing nacelle (OWN) and rear-fuselage nacelle (RFN) configurations. It is basically produced by the wing shielding in the OWN of the ROSAS twin-finned tail plane. In the RFN configuration, the shielding effect is also supported by the fuselage influence (Figure 4.2). Negative effects linked to under wing nacelle configurations such as jet-wing or jet-flap interactions and noise reflections from the pressure side of the wing are no longer present. Thanks to the large parametric study achieved during the ROSAS wind tunnel test campaign, a large range of installation effects on fan, jet and turbine noise are described and analysed in OWN and RFN silent aircraft configurations. The experimental findings will be complemented by a computational activity, which has been initiated to assess the influence of flow inhomogeneities on the propagation and scattering of noise.

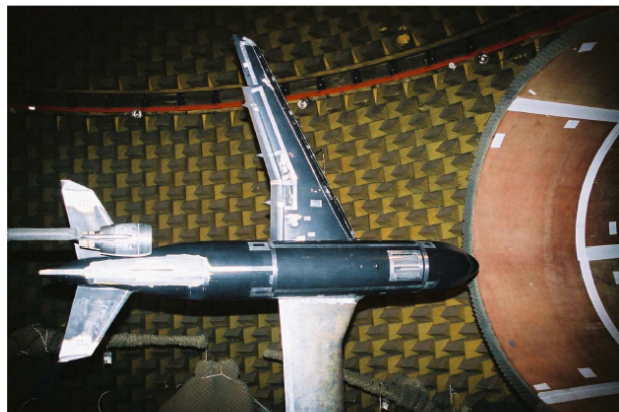

Figure 4.1: Fan noise test in ONERA CEPRA 19: ROSAS model and TPS nacelle, RFN layout

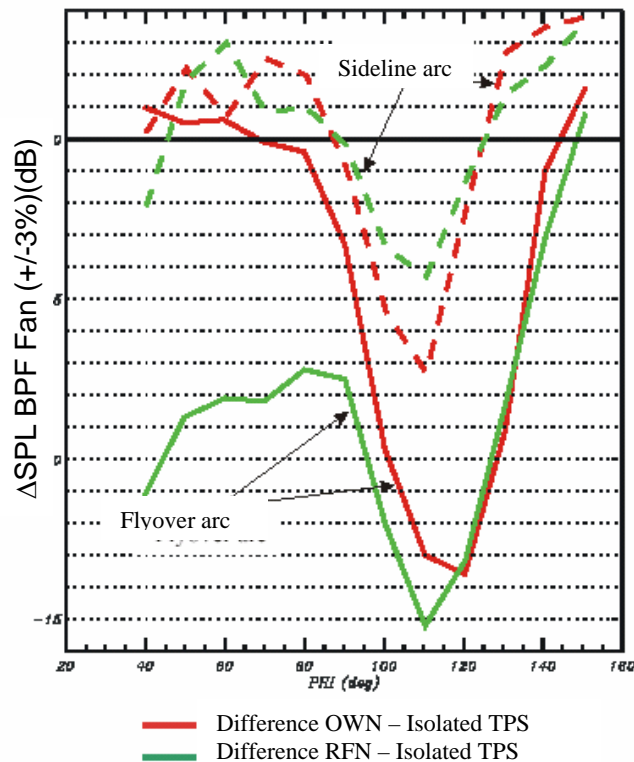

Figure 4.2: Shielding effect on the fan blade passage frequency (BPF) directivities for the OWN and RFN aircraft configurations. Difference SPL level versus Isolated TPS configuration. - RPM = 32500 - $V_s = 60$ m/s

[By H. Brouwer, NLR, Emmeloord, The Netherlands]

4.2. TRANSONIC HELICOPTER NOISE

In recent years, factors such as environmental acceptability of ground noise levels, passenger comfort and acoustic detectability have elevated the importance of noise in helicopter rotor design. At present cruise speeds, shock associated rotor noise is a major noise source, and yet predicting it in a way which is sufficiently fast and physically insightful to be useful to rotor designers has been a challenge.

In recent work, the Ffowcs Williams – Hawkins (FW-H) equation [4.2.1] has been applied in a different way to enable computationally efficient and insightful calculations of shock-associated rotor noise. The permeable surface form of the FW-H equation is used. The sound field being expressed in terms of a distribution of monopole and dipole sources over a permeable control surface, and a distribution of quadrupole sources over the volume outside of the control surface. By choosing the control surface to enclose the transonic flow regions, the noise from the quadrupole distribution becomes negligible. Only the more straightforward sources then need to be considered, making the acoustic approach computationally efficient. By locating the control surface close to the blade subject to enclosing the transonic flow regions, efficiency in the computational fluid dynamics (CFD) approach is also attained. Furthermore, by comparing the noise prediction with that obtained when the surface terms of the FW-H equation are applied to the blade surface, the “thickness”, “loading” and “quadrupole” contributions to the overall noise can be recovered, providing useful physical design guidance.

A CFD method for calculating the flow field around the blade, and hence the “acoustic sources” on the permeable control surface, has been developed [4.2.2, 4.2.3]. The method is an unsteady conservative

Euler solver which incorporates high resolution shock-capturing techniques and non-reflecting external boundary conditions. It is characteristics-based and is first order accurate in time and third order accurate in space. In parallel with this, an acoustic method for incorporating the permeable surface form of the FW-H equation has been developed [4.2.3, 4.2.4]. This uses the retarded time formulation of the FW-H equation to integrate the relevant variables over the permeable control surface in order to predict the radiated sound. Rigid blade motions are assumed in both methods.

The CFD and acoustic methods have been combined to perform noise predictions for rotor blades in hover and forward flight, all of which involve transonic flows but for which shock delocalisation does not occur [4.2.3]. In Figure 4.3 the predictions for two hover benchmark test cases are compared to those obtained using other methods. The predictions from the permeable surface form of the FW-H are at least as good as those from other integral methods, and also use the most computationally efficient approach. A paper describing this approach received a Best Paper Award from AHS International.

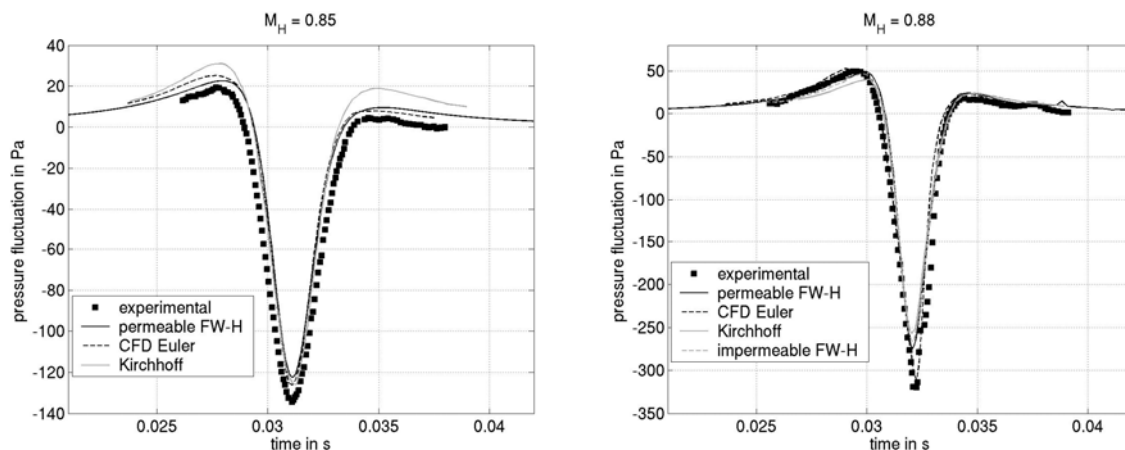

Figure 4.3: Noise for non lifting UH-1H blade in hover: $M_H = 0.85$ (left) and $M_H = 0.88$ (right)

Although the calculation of the control surface acoustic sources using unsteady CFD is feasible for straightforward helicopter motion, for more complicated manoeuvres it becomes too time consuming for use in design. Low order modelling may provide an efficient alternative; mathematical models have been developed to approximate the temporal variation of the acoustic sources for given variations in flight condition. Results from CFD simulations indicated that the system was dynamically linear for sufficiently small changes, and so linear input/output system identification techniques could be used to develop models. So far, models have been developed which are valid in 2-D flow in which the control surface section is acoustically compact [4.2.4]. These have successfully been used in noise prediction, demonstrating the potential of low order modeling in predicting transonic helicopter noise.

[By A. S. Morgans, S. A. Karabasov, A. P. Dowling and T. P. Hynes, University of Cambridge, Cambridge, United Kingdom]

4.3. EVALUATION OF NOISE EXCESS FOR PUSHING PROPELLER AIRCRAFT

Piaggio Aero Industries, the Department of Aeronautical Design of the University of Naples Federico II and INSEAN tackle within the Italian research project VITAS the problem of evaluation of noise excess for pushing propeller aircraft configuration. The airplane examined is the three lifting surface aircraft P180 Avanti (Figure 4.4). Since the propellers are located downstream of the trailing edge of the wing and engine exhausts, they operate in perturbed-air conditions and need to be carefully analyzed to simulate the generation of excess of noise and define proper blade shape for future design improvements.

Using the flow field solution (Figure 4.5), the numerical aeroacoustic analysis is to determine the acoustic performance of the P180 basic propeller. It will be used as a baseline comparison for the

aeroacoustic behavior of a possible novel propeller design. In the experimental investigation ground and flight tests for a prototype aircraft and wind tunnel tests for a motorized P180 scaled model are planned in 2004. Furthermore, a numerical tool based on the single source noise characteristics to predict the aircraft community noise levels on the certification point will be developed. The method will be combined with standard commercial software, which is capable to predict the footprint on the ground and as such enables an optimization as to noise levels near airports for take-off and landing.



Figure 4.4: P180 Ground noise test for exhaust shape and orientation optimization

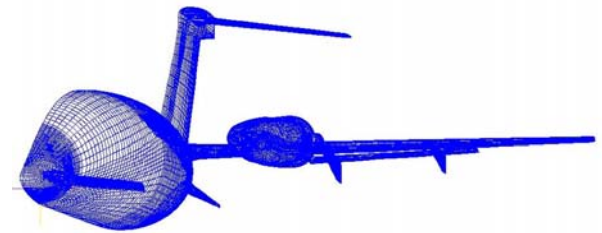

Figure 4.5: P180 Computational fluid dynamics surface mesh

[By A. Sollo, Piaggio Aero Industries, Genoa, Italy]

5. THEORETICAL METHODS

5.1. HIGHER-ORDER DISCONTINUOUS GALERKIN METHODS FOR AEROACOUSTICS

The University of Twente is working on the development of higher-order Discontinuous Galerkin methods for aeroacoustics, in cooperation with TNO-TPD Delft. Recently an implementation on tetrahedral elements has been verified for duct acoustics including a vibrating part of the wall. To this end an analytical solution has been derived for a duct with a rectangular cross-section [5.1.1]. Testcases include a plunging wall segment as well as harmonic vibrations, for uniform flow conditions and for Hagen-Poiseuille flow conditions. Currently an implementation on hexahedral elements is being developed. The wave propagation properties of the Discontinuous Galerkin method have been analysed in relation to the spatial discretisation of a scalar linear advection equation in one spatial dimension. To this end the governing characteristic polynomial has been analytically derived and a numerical study of the roots of the polynomial has been conducted. In the literature it has been shown that the dispersion relation corresponding to the spatially $(p+1)$ -th order accurate discretised advection equation leads to a Padé approximation of the exponential function for $0 \leq p \leq 16$. Our investigation showed how the Padé approximation is generated by a recursion that is induced by the discretisation method. This recursion is different from the one found in the literature. A proof of the equivalence of the two recursions has been derived. Finally, dispersion and dissipation error estimates found in the literature for $0 \leq p \leq 16$ have been generalized to $p \geq 0$.

[By R. Hagmeijer, H.W.M. Hoeijmakers, C.P.A. Blom and H. Özdemir, University of Twente, Enschede, The Netherlands]

5.2. ADER TIME INTEGRATION FOR FINITE-VOLUME AND DISCONTINUOUS GALERKIN METHODS

The commonly used Runge-Kutta type time integration methods suffer under the problem that for orders higher than four they become very costly. The arbitrary high-order schemes using derivatives (ADER) possess two advantages. The method can be easily extended to arbitrary high order temporal integration and it ensures conservation in space and in time. To calculate the time-integrated fluxes at the cell boundaries in a finite-volume framework, the solution is expanded in a Taylor series in time where time-derivatives are replaced by successive use of the original differential equation. A sequence of generalized Riemann problems is then solved for the reconstructed values and their derivatives. The method was first developed in a finite-volume (FV) context by Toro [5.2.1]. Our version of finite-volume ADER schemes for the linearized Euler equations [5.2.2] is very fast and has excellent stability and wave propagation properties. On structured grids numerical convergence studies were performed up to 24th order in space and time. The twelfth-order version in space and time needs as much computational time as the DRP scheme while requiring only 1/3 of the memory and the ADER scheme has better wave resolution properties. Since the reconstruction process for very high-order schemes turns out to be complicated and expensive on unstructured grids, we applied the ADER idea to the discontinuous Galerkin (DG) framework where piecewise high-order polynomial basis functions in each element provide easy access to all space derivatives [5.2.3]. The ADER-DG and ADER-FV methods are combined to yield a high-order aeroacoustic solver for general geometries.

[By C. D. Munz, T. Schwartzkopf and M. Dumbser, University of Stuttgart, Stuttgart, Germany]

5.3. NOISE PREDICTION OF FLUID MACHINERY USING LES

The acoustics of a simple axial flow machinery, a simplified propeller with two blades (Figure 5.1), is investigated using a coupled large-eddy simulation (LES) and Ffowcs Williams-Hawkings solver. The LES is carried out in a rotating computational domain. The Reynolds number based on the tip velocity and the chord length is approx. 130,000. The numerical prediction of the sound pressure level in Figure 5.2 shows a satisfactory agreement with the experimental data even on a coarse LES grid of 1.3×10^6 control volumes [5.3.1].

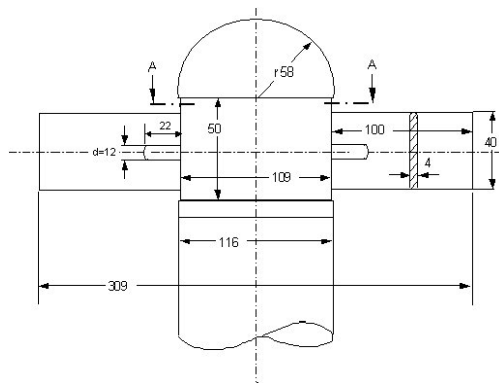

Figure 5.1: Technical drawing of the simplified propeller

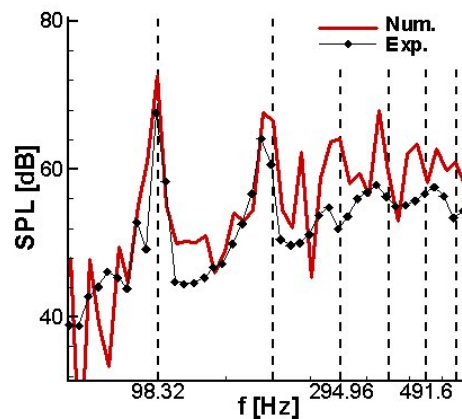

Figure 5.2: Experimental and numerical sound pressure level of the simplified propeller

[By E. Sorgüven, F. Magagnato and M. Gabi, University of Karlsruhe, Karlsruhe, Germany]

5.4. SOUND PROPAGATION IN DUCTS OF ARBITRARY CROSS SECTION

The multiple-scales solution for modes in slowly varying annular and cylindrical lined ducts with homentropic irrotational mean flow that was found [5.4.1] earlier has been generalized [5.4.2] for ducts of *arbitrary* cross section (Figure 5.3). A modal adiabatic invariant has been identified, leading to an exact solution of the multiple-scales problem, given the cross-sectional Laplace eigensolutions. In addition, the turning point analysis is given for a single hard-wall cut-on, cut-off transition. This appears to yield the same reflection and transmission coefficients as in the circular duct problem.

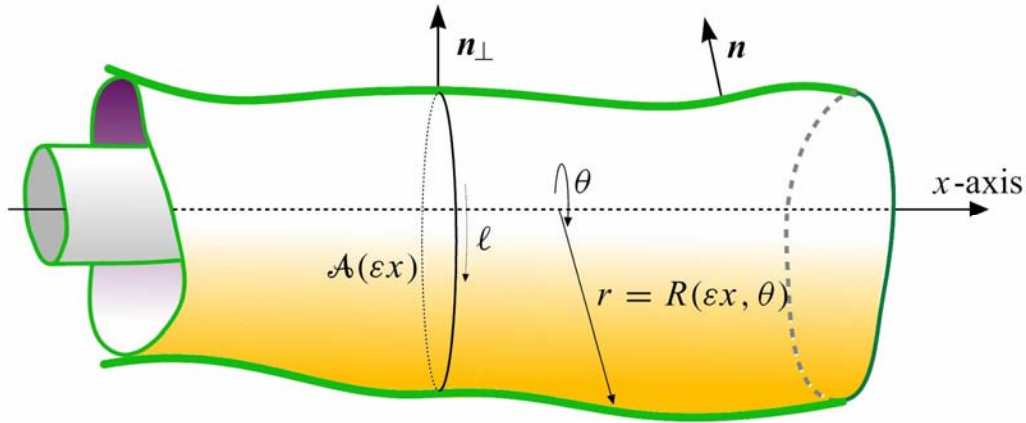

Figure 5.3: Sketch of slowly varying duct geometry

[By S.W. Rienstra, Eindhoven University of Technology, Eindhoven, The Netherlands]

5.5. A MATCHING METHOD FOR CFD SOURCE AND CAA PROPAGATION REGIONS

In the context of the EU project “TurboNoiseCFD”, a matching method is developed [5.5.1] to connect the computational fluid dynamics (CFD) source region to the computational aeroacoustics (CAA) propagation region of rotor-stator interaction sound produced in a turbofan engine. The method is based on a modal decomposition across three neighbouring axial interfaces adjacent to the matching interface (Figure 5.4). The modal amplitudes are determined by a least-squares fit. By taking slowly varying modes the interface may be positioned in a duct of varying cross section. Furthermore, the spurious reflections back into the CFD domain, which result from imperfect reflection-free CFD boundary conditions, can be filtered out by including both left- and right-running modes in the matching. Although the method should be wider applicable, it is implemented and tested for homentropic potential flow in lined ducts. This is very relevant for the inlet side, and a good model for the bypass side if swirl or other types of vorticity are not dominant in the mean flow. By matching with density or pressure perturbations any contamination of residual non-acoustical vorticity is avoided.

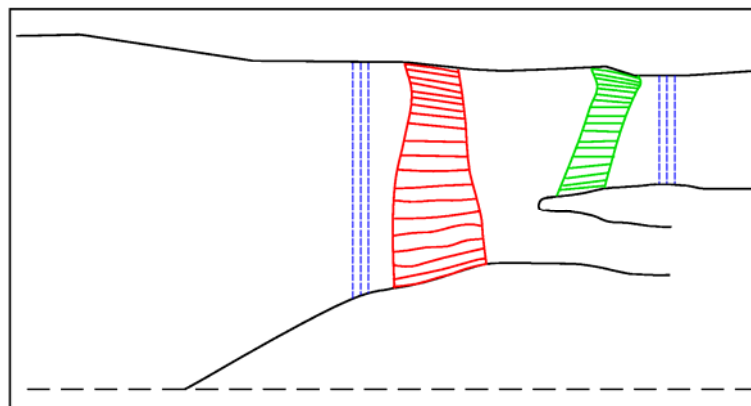

Figure 5.4: Sketch of triple-plane matching inlet and bypass geometry

6. AIRFRAME NOISE

6.1. EFFECT OF SLAT GAP ON FARFIELD RADIATED NOISE AND CORRELATION WITH LOCAL FLOW CHARACTERISTICS

“Handley-Page”-type slats were identified as dominating high-lift device noise sources of transport aircraft through numerous wind tunnel experiments in the last 5 years. These experiments evidenced (i) slat noise to be governed by upper slat trailing edge noise and (ii) the sensitivity of this noise mechanism with respect to the actual position of the slat relative to the main element. Since the latter also determines the aerodynamic high-lift performance, slat gap and overlap can be considered key parameters for a combined aerodynamic/acoustic optimisation of high-lift systems.

Wind tunnel experiments were performed on a generic 3-element high-lift wing configuration in DLR’s Aeroacoustic Wind-Tunnel in Braunschweig to determine the influence of slat gap variations on farfield radiated slat noise. From a baseline reference gap dimension the gap size was reduced in two steps to 91% and 85% of this reference. For these configurations local flow features and overall aerodynamic performance data were determined by 2D Reynolds-averaged Navier-Stokes (RANS) calculations. Acoustic data were acquired using an elliptical mirror.

The results from this study [6.1.1] showed for the aerodynamically optimised high-lift system a reduction in slat gap width to provide a local noise reduction of up to 10 dB while $c_{L,max}$ only slightly decreased (Figure 6.1). In order to determine a correlation of acoustic data with local flow parameters the local velocities at the slat’s upper and lower trailing edges were determined. It turned out that slat noise frequencies scale best on a Strouhal number basis calculated with the local flow velocity at the lower surface of the upper slat trailing edge (Figure 6.2). This result indicates the turbulent cove-side flow off the upper slat trailing edge to represent the major source of broadband slat noise.

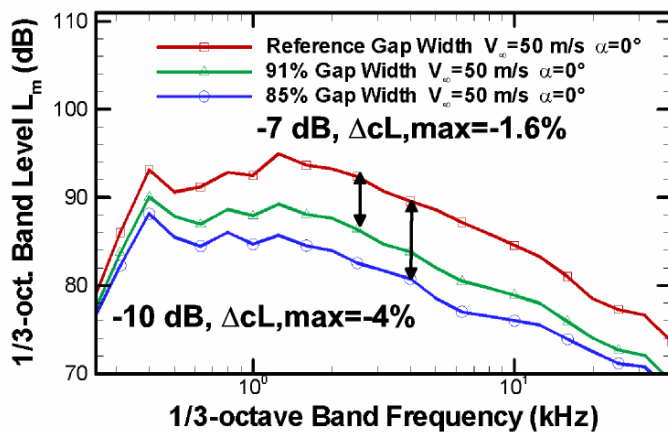

Figure 6.1: Effect of gap width on “as measured” slat noise spectra for 50m/s inflow speed and zero angle-of-attack

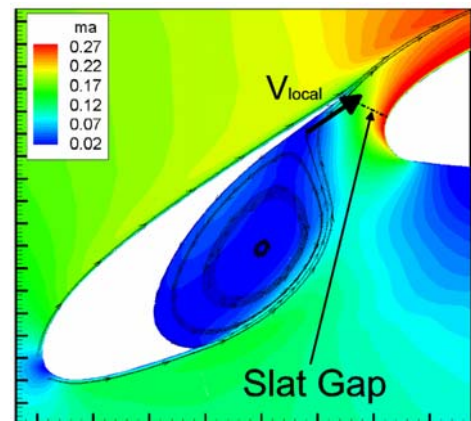

Figure 6.2: Mach number contours at a wing angle-of-attack of 4 deg and a slat deflection angle of 26 deg

7. ADVANCED TESTING TECHNIQUES

7.1. AN ANALYTICAL METHOD FOR EXTRACTING LINER IMPEDANCE FROM MEASUREMENTS

The in-situ method has been used for a long time as an easy, quick and direct method for measuring acoustic liner impedance with and without flow. Nevertheless, several drawbacks and problems have been reported with the use of this method. These problems motivated Watson et al. [7.1.1] to develop an indirect, finite element based method to measure the impedance. A similar, yet simpler, method has been developed at KTH [7.1.2]. The liner sample is placed inside a rectangular duct. The amplitude of the plane wave incident towards the lined section and the reflection coefficient at the exit plane are measured using the two-microphone technique. The measured values are fed into an analytical model for sound propagation through the lined section, which is coupled to the inlet and outlet duct by mode matching. A solution of the impedance value is deduced in the complex plane to match the calculated and the measured sound field. The measured pressures at the microphone locations shown in Figure 7.1 are used as the control criterion. This method is indeed faster and simpler than the finite element method, but the disadvantage is that it cannot handle complicated liner configurations, e.g. axial or circumferential variation of the impedance. Circumferential variation can be included in the present formulation by recalculating the wave numbers in the lined duct, while axial variation implementation requires extension to mode matching at each impedance step.

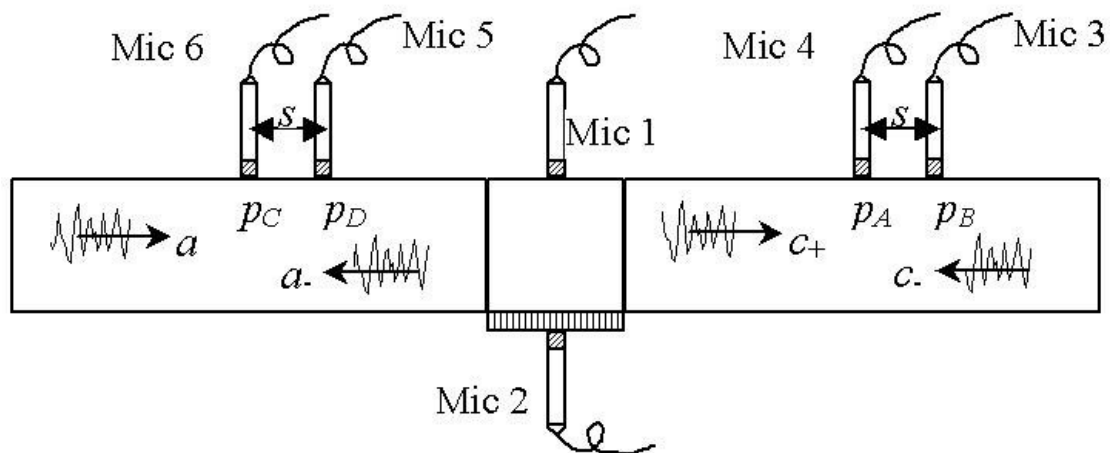

Figure 7.1: Impedance eduction measurement points

[By T. Elnady and H. Bodén, KTH, Stockholm, Sweden]

8. JET AEROACOUSTICS

8.1. A STUDY OF MACH 0.75 JETS AND THEIR RADIATED SOUND

In the European framework programme JEAN (Jet Exhaust Aerodynamics and Noise) large-eddy simulations (LES) of a compressible nozzle/jet configuration have been carried out. Two jets were simulated, an isothermal jet and a jet with a higher temperature than the surrounding air. The Mach number was in both cases 0.75 and the jet Reynolds number was 5.0×10^4 . Sound pressure levels in far-field observer locations were evaluated using Kirchhoff surface integration and Lighthill's acoustic analogy. The Favre filtered Navier-Stokes equations were solved using a finite volume method solver with a low-dissipation third-order upwind scheme for the convective fluxes, a second-order centered difference approach for the viscous fluxes and a three-stage second-order Runge-Kutta time marching technique. The computational domain was discretized using a block structured boundary fitted mesh

with approximately 3.0×10^6 cells. The calculations were performed on a parallel computer, using message-passing interface (MPI). A compressible form of Smagorinsky's subgrid scale model was used for computation of the subgrid scale stresses. Absorbing boundary conditions based on characteristic variables were adopted for all free boundaries. Velocity components specified at the entrainment boundaries were estimated from corresponding Reynolds Averaged Navier-Stokes (RANS) calculations, which enable the use of a rather narrow domain. This ensures that the correct amount of fluid is entrained into the domain. Two-point space-time correlations were obtained for locations in the shear layer center, from which length and time scales of turbulence structures were evaluated. Aerodynamic results and predicted sound pressure levels are in good agreement with experiments. The predicted sound pressure levels were for all observers within a 3dB deviation from the measured levels and for most observers within a 1dB deviation [8.1.1, 8.1.2, 8.1.3].

[By N. Andersson, L. Davidson and L. E. Eriksson, Chalmers University of Technology, Göteborg, Sweden]

9. COMBUSTION NOISE

9.1. INTERACTION OF FLAME ACOUSTICS AND LINER VIBRATIONS IN A GAS TURBINE

To decrease NO_x emissions from a combustion system lean premixed combustion in combination with an annular combustor is used. The disadvantage is that sound pressure levels in the combustion system become higher, which in turn excite the liner. This limits the life of the combustor, because it will fail earlier due to fatigue. This problem is studied in the European project DESIRE (DESIGN and demonstration of highly RELIABLE low NO_x combustion systems for gas turbines).

The study was started with a simplified model without combustion consisting of a rigid rectangular box with a flexible plate on one of the sides. Sound is injected into the box using a tube coming from a rectangular box with a loudspeaker inside. A fully coupled finite element model was developed of the structure and the acoustic cavity. The results of the model are compared with the measurements performed on the actual setup. Both the structural mode shapes measured using a laser vibrometer and the transfer functions from pressure to displacement match very well. Furthermore it was shown that the influence of the cooling cavity surrounding the liner on the dynamic behaviour of the liner is substantial.

The coupled finite element method is now combined with a simplified flame transfer function using a transfer function approach to study the interaction between unstable combustion and structural vibration. Thermal effects on the liner and the acoustics are also included. These models will be validated in a 500 kW experimental test rig in which it is possible to measure flame shape (PLIF), acoustic pressure fluctuations and structural vibrations during combustion.

[By R.A. Huls, P. van der Hoogt and A. de Boer, University of Twente, Enschede, The Netherlands]

REFERENCES

- 3.3.1 S. De Rosa, F. Franco and D. Melluso 2003 Analysis of Radiated Power from a Plate in a Turbulent Boundary Layer, Euronoise 2003 Conf., Naples, Italy, 19-21 May 2003, Paper #47.
- 3.3.2 S. De Rosa, F. Franco and D. Melluso 2003 The Analysis of the Stochastic Response of Plates: a Review of the Project ENABLE, XVII AIDAA National Congress of the Italian Association for Aeronautics and Astronautics, Rome 15-19 September 2003, 167-176.
- 3.3.3 S. De Rosa, F. Franco, G. Romano and F. Scaramuzzino 2004 Modal Expansions for the Random Structural Response due to a Turbulent Boundary Layer Excitation, accepted for publication in Wind and Structures, an International Journal.

- 4.2.1 J. E. Ffowcs Williams and D. L. Hawkings 1969 Sound Generated by Turbulence and Surfaces in Arbitrary Motion, *Philosophical Transactions of the Royal Society*, A264:321-342.
- 4.2.2 S. A. Karabasov and T. P Hynes 2002 Open boundary conditions of predictor-corrector type for external flows, 8th AIAA/CEAS Aeroacoustics Conference, 2002-2442, Breckenridge, CO, USA.
- 4.2.3 A. S. Morgans, S. A. Karabasov, A. P. Dowling and T. P Hynes 2003 59th American Helicopter Society Annual Forum, Phoenix, AZ, USA.
- 4.2.4] A. S. Morgans and A. P. Dowling 2002 The Aeroacoustics of Transonic Helicopter Blades, 8th AIAA/CEAS Aeroacoustics Conference, 2002-2545, Breckenridge, CO, USA.
- 5.1.1 C.P.A. Blom 2003 Discontinuous Galerkin Method on Tetrahedral Elements for Aeroacoustics, Ph.D. thesis, University of Twente.
- 5.2.1 E.F. Toro, R.C. Millington and L.A.M. Nejad 2001 Towards Very High Order Godunov Schemes, in E. F. Toro (Ed.), *Godunov Methods: Theory and Applications*, Kluwer Academic, 905-937.
- 5.2.2 T. Schwartzkopff, M. Dumbser and C.-D. Munz 2004 Fast High Order ADER Schemes for Linear Hyperbolic Equations, accepted for publication in *Journal of Computational Physics*.
- 5.2.3 M. Dumbser 2003 On the Improvement of Efficiency and Storage Requirements of the Discontinuous Galerkin Method for Aeroacoustics, *PAMM - Proceedings in Applied Mathematics and Mechanics*, Vol. 3.
- 5.3.1 E. Sorgüven, F. Magagnato and M. Gabi 2003 Prediction of the far field noise of a simplified propeller with large eddy simulation, DGLR Paper 2003-068.
- 5.4.1 S.W. Rienstra 1999 Sound Transmission in Slowly Varying Circular and Annular Ducts with Flow, *Journal of Fluid Mechanics* 380, 279 – 296.
- 5.4.2 S.W. Rienstra 2003 Sound Propagation in Slowly Varying Lined Flow Ducts Of Arbitrary Cross Section, *Journal of Fluid Mechanics* 495, 157-173.
- 5.5.1 N.C. Ovenden and S.W. Rienstra 2003 Mode-Matching Strategies in Slowly Varying Engine Ducts, Paper AIAA 2003-3139 of the 9-th Aeroacoustics Conference in Hilton Head, SC, 12-14 May 2003, accepted for publication in *AIAA Journal*.
- 6.1.1 M. Pott-Pollenske, J. Alvarez-Gonzales and W. Dobrzynski 2003 Effect of Slat-Gap on Farfield Radiated Noise and Correlation with Local Flow Characteristics, AIAA-2003-3228, 12-14 May 2003, Hilton Head, South Carolina/USA.
- 7.1.1 W.R. Watson, M.G. Jones, S.E. Tanner and T.L. Parrott 1996 Validation of a numerical method for extracting liner impedance, *AIAA Journal*, vol. 34(3), 548-554.
- 7.1.2 T. Elnady and H. Bodén 2004 An Analytical Method for Extracting Liner Impedance from Measurements, 10th AIAA/CEAS Aeroacoustics Conference, Manchester, UK.
- 8.1.1 N. Andersson, L.-E. Eriksson and L. Davidson 2003 Large-Eddy simulation of a Mach 0.75 jet, 9th AIAA/CEAS Aeroacoustic Conference, AIAA 2003-3312, Hilton Head, South Carolina.
- 8.1.2 N. Andersson 2003 A Study of Mach 0.75 Jets and Their Radiated Sound, Licentiate Thesis, Chalmers University of Technology, Division of Thermo and Fluid Dynamics, Göteborg, Sweden.
- 8.1.3 P. Jordan, Y. Gervais and J.-C. Valière 2003 Modeling Self and Shear Noise Mechanisms in Anisotropic Turbulence, 9th AIAA/CEAS Aeroacoustic Conference, AIAA 2003-8743, Hilton Head, South Carolina.

ACKNOWLEDGEMENT

The author wishes to thank Ms. Monika Wiechol for her contribution to the production of this paper.